

Subject: Visual identification of Kelsey-Hayes ABS components

Source: General Motors service manuals

This reference contains the following illustrations to help identify the different types of Kelsey-Hayes ABS components:

- [Figure G2019-1](#) Kelsey-Hayes EBC310 4WAL system ECU
- [Figure G2019-2](#) Kelsey-Hayes EBC4 4WAL system connector pin configuration
- [Figure G2019-3](#) RWAL control valve assemblies
- [Figure G2019-4](#) Kelsey-Hayes EBC 325 & EBC 325S (w/NW7) used on Avalanche, Silverado, S10, Trailblazer, Tahoe, Astro and Safari
- [Figure G2019-5](#) Kelsey-Hayes EBC 325 & EBC 325S (w/NW7) BPMV hydraulic flow
- [Figure G2019-6](#) Kelsey-Hayes EBC 325 used on 2000 and later S10 Blazer and Pickup
- [Figure G2019-7](#) Kelsey-Hayes EBC 325 BPMV hydraulic flow
- [Figure G2019-8](#) Kelsey-Hayes 325 EV used on a G-Series van
- [Figure G2019-9](#) Kelsey-Hayes EHCUC used on C- & K-Series pickups
- [Figure G2019-10](#) Kelsey-Hayes ABS for a P-Chassis (Workhorse)
- [Figure G2019-11](#) Kelsey-Hayes 310 ABS for 2000 S10 Blazer and Pickup

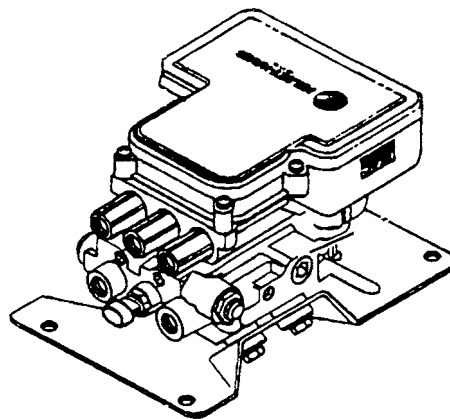

Figure G2019-1 Kelsey-Hayes EBC310 4WAL system ECU

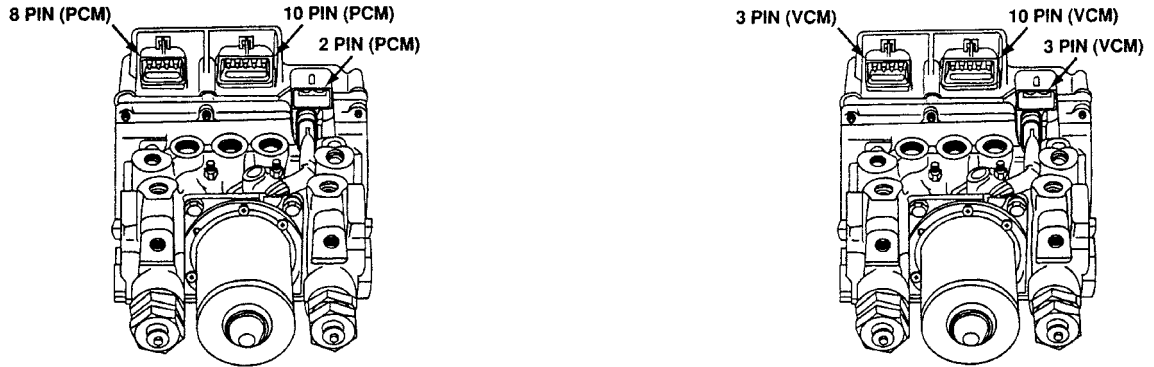

Figure G2019-2 Kelsey-Hayes EBC4 4WAL system connector pin configuration

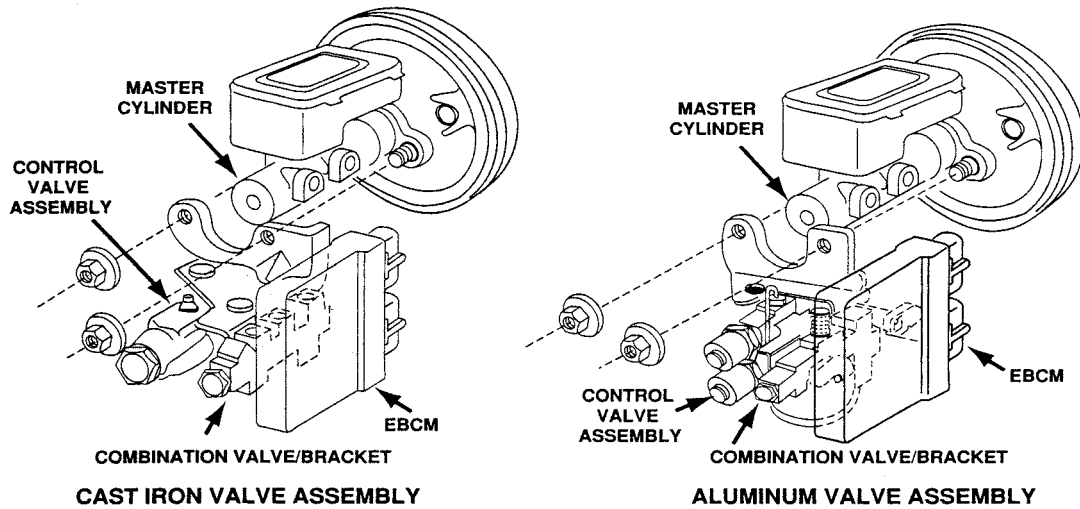

Figure G2019-3 RWAL control valve assemblies

RWAL control valve assemblies can be cast iron or aluminum. In either case, if the EBCM is attached the system is standard RWAL; if no EBCM is attached, the system is VCM RWAL.

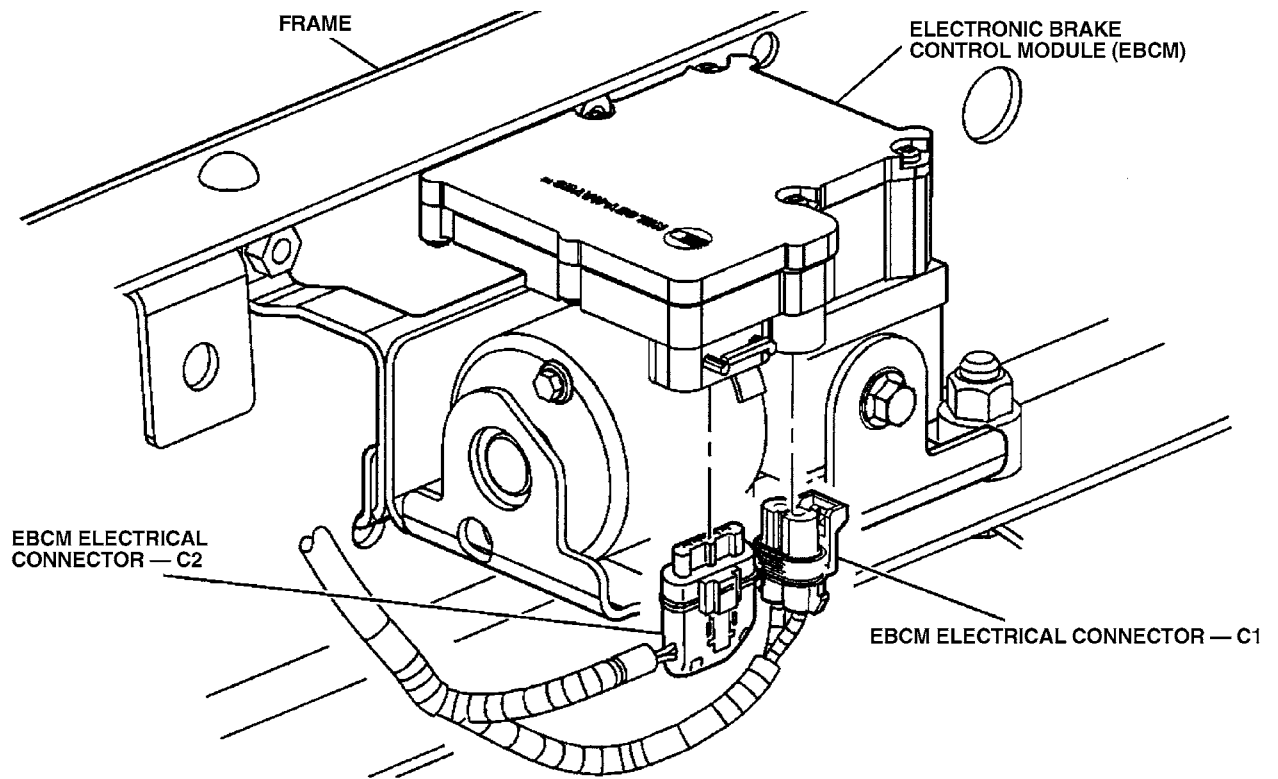

Figure G2019-4 Kelsey-Hayes EBC 325 & EBC 325S (w/NW7) used on Avalanche, Silverado, S10, Trailblazer, Tahoe, Astro and Safari

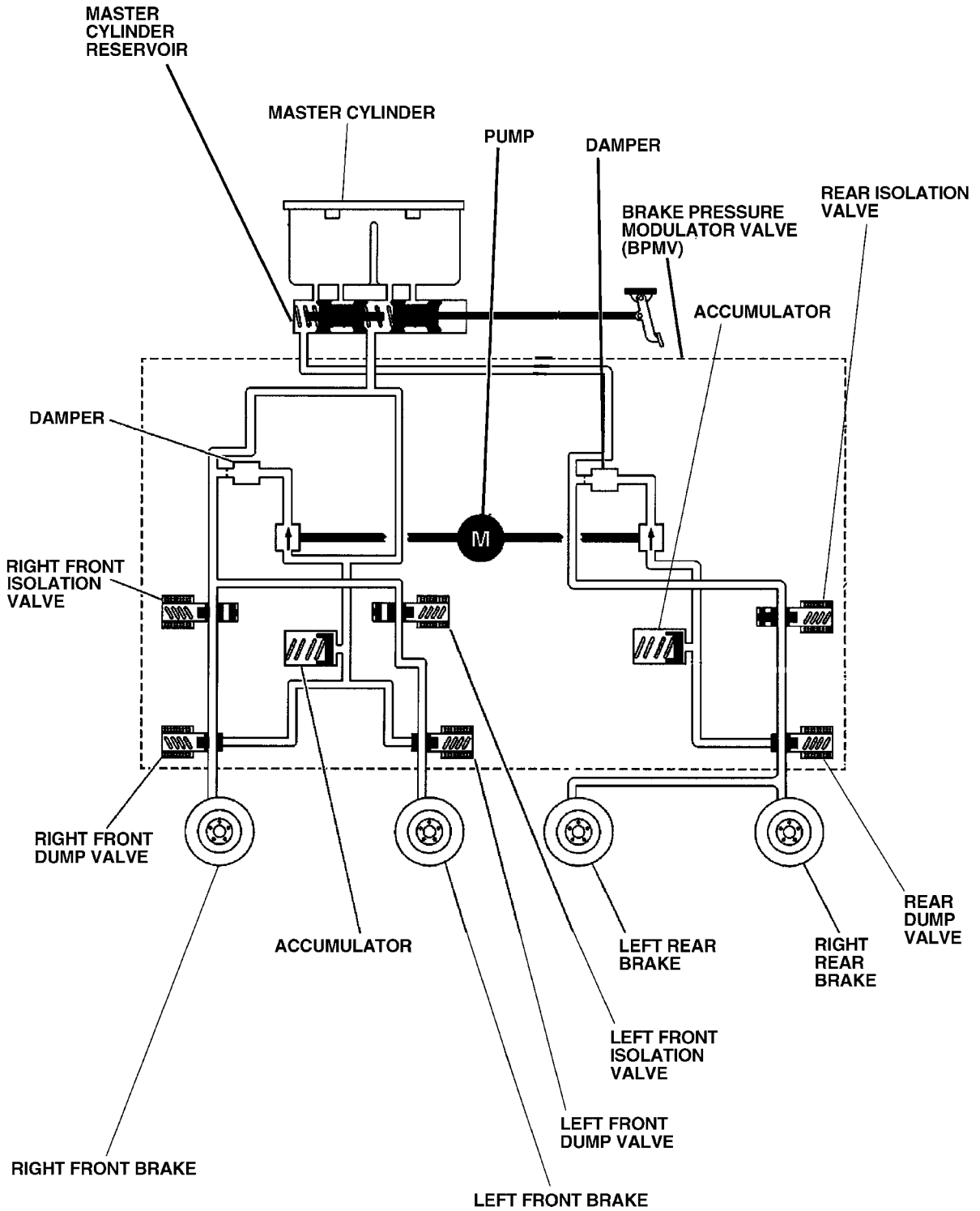

Figure G2019-5 Kelsey-Hayes EBC 325 & EBC 325S (w/NW7) BPMV hydraulic flow

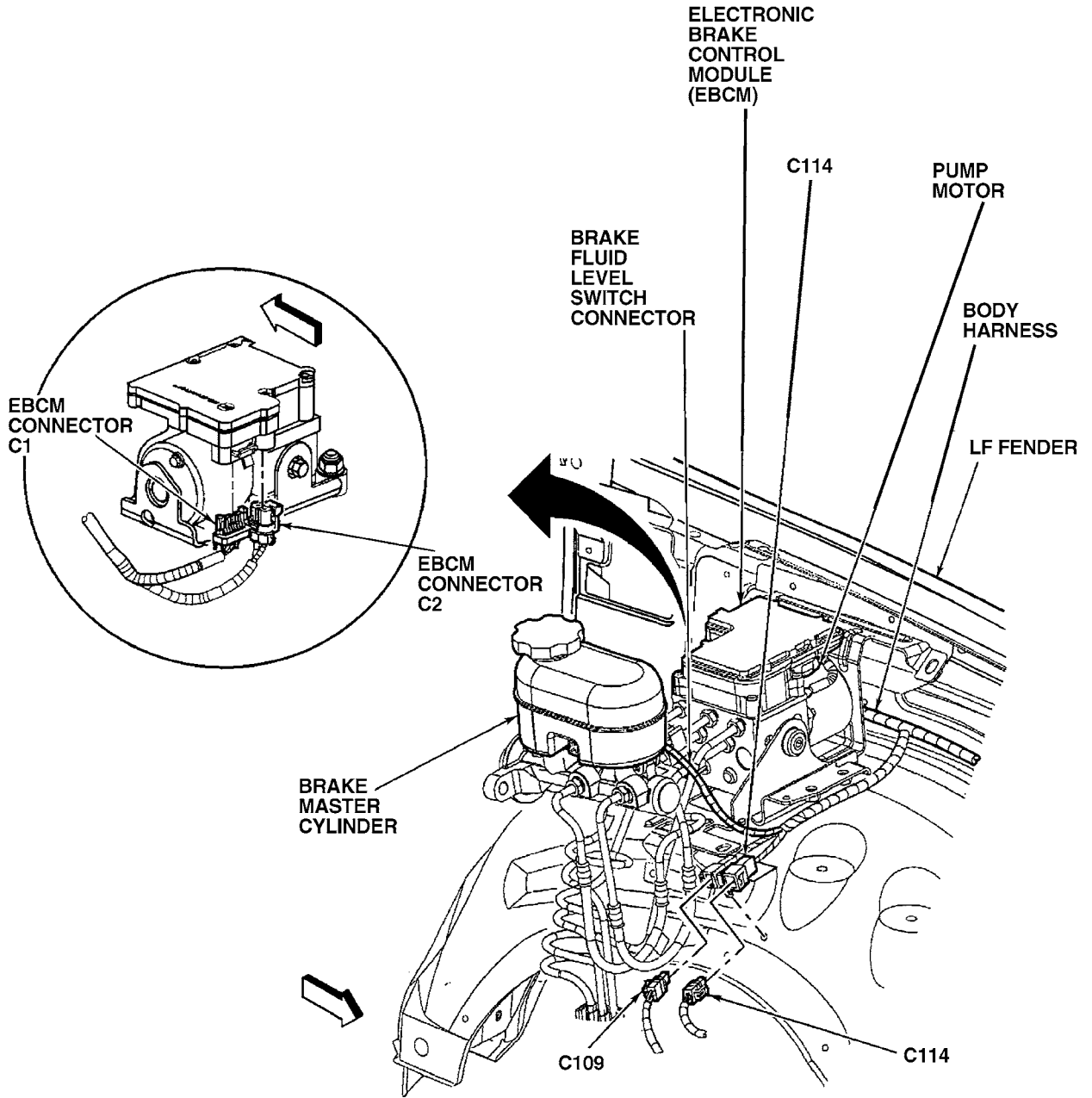

Figure G2019-6 Kelsey-Hayes EBC 325 used on 2000 and later S10 Blazer and Pickup

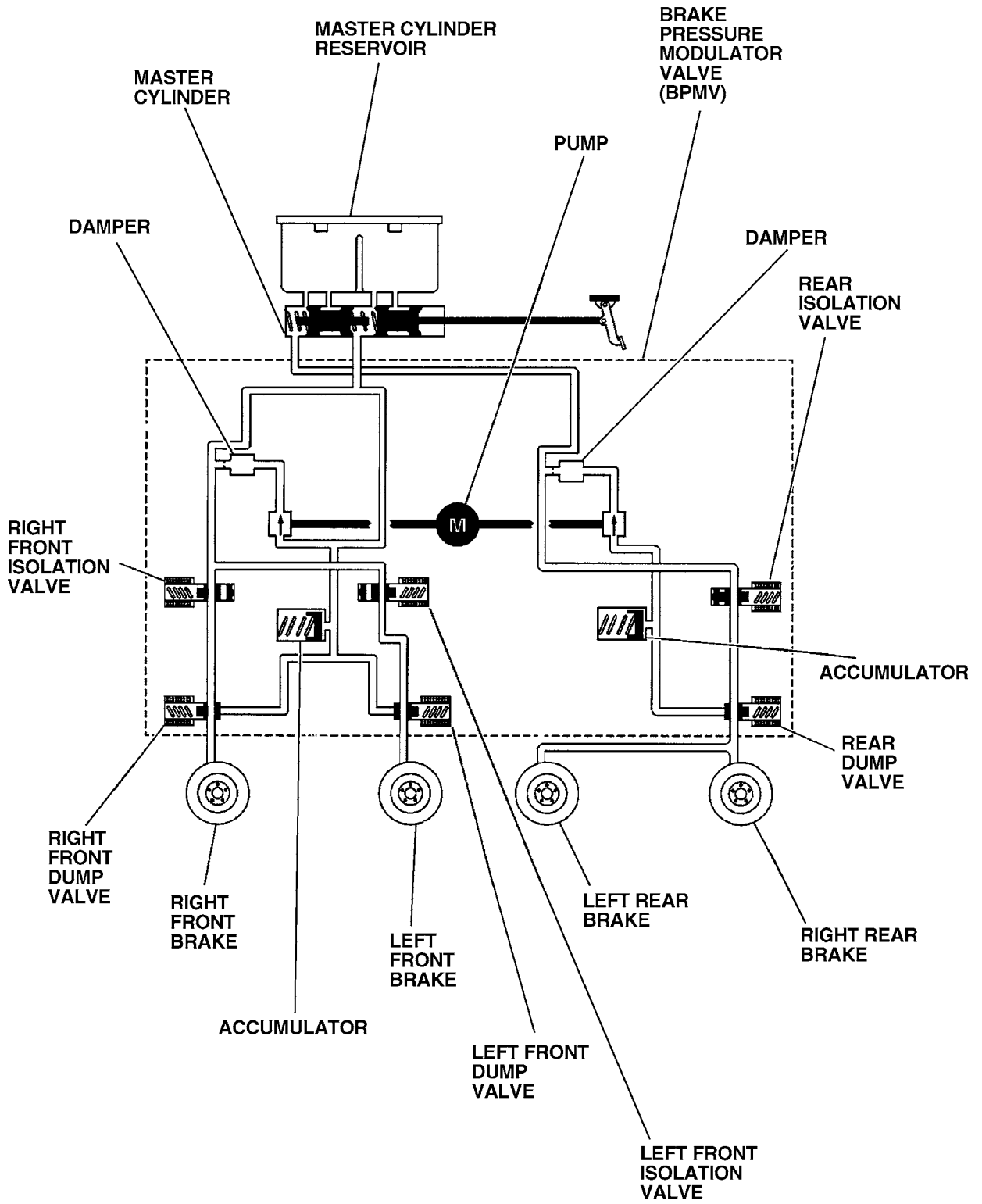

Figure G2019-7 Kelsey-Hayes EBC 325 BPMV hydraulic flow

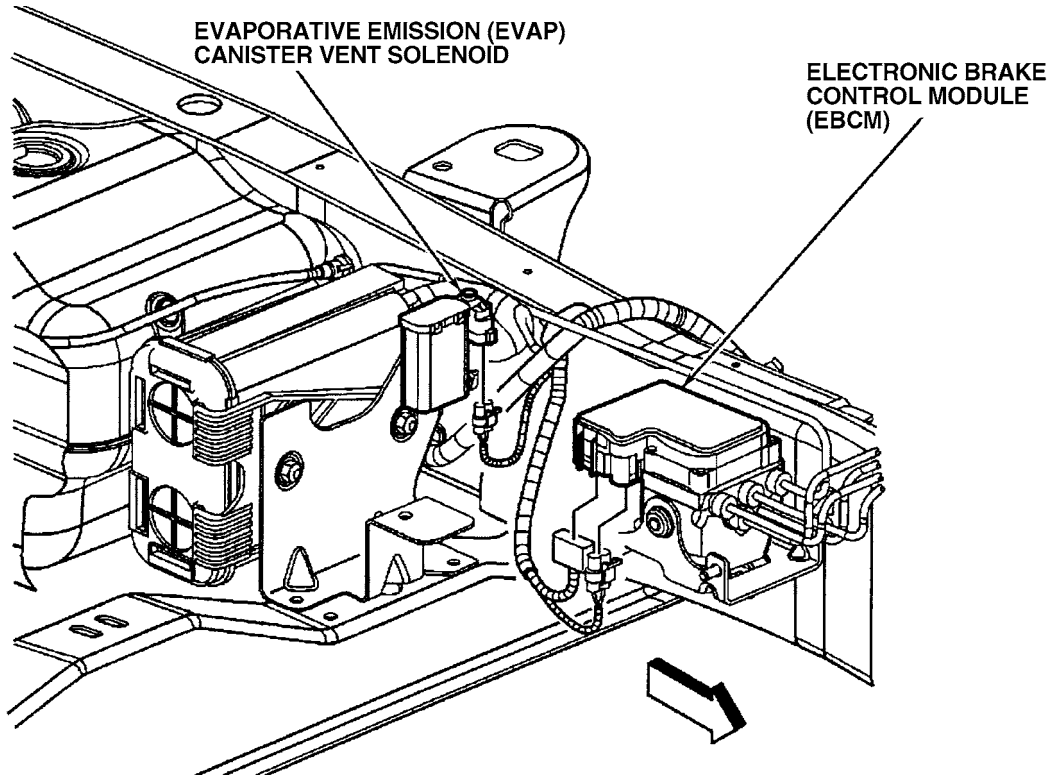

Figure G2019-8 Kelsey-Hayes 325 EV used on a G-Series van

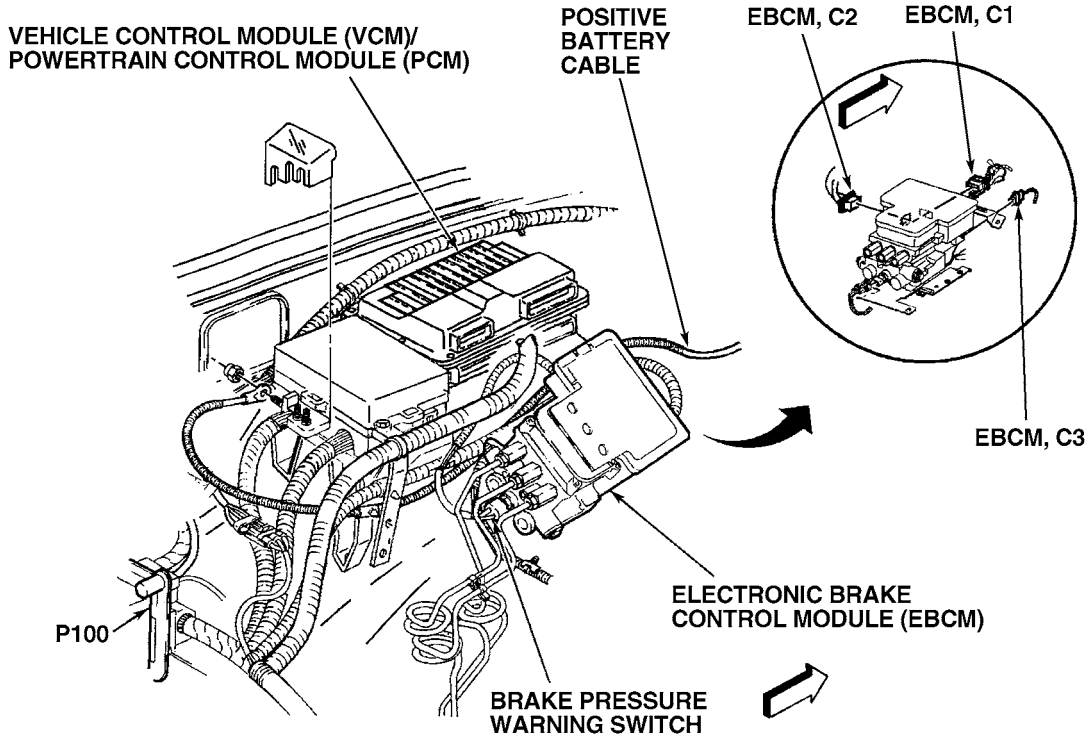

Figure G2019-9 Kelsey-Hayes EHCU used on C- & K-Series pickups

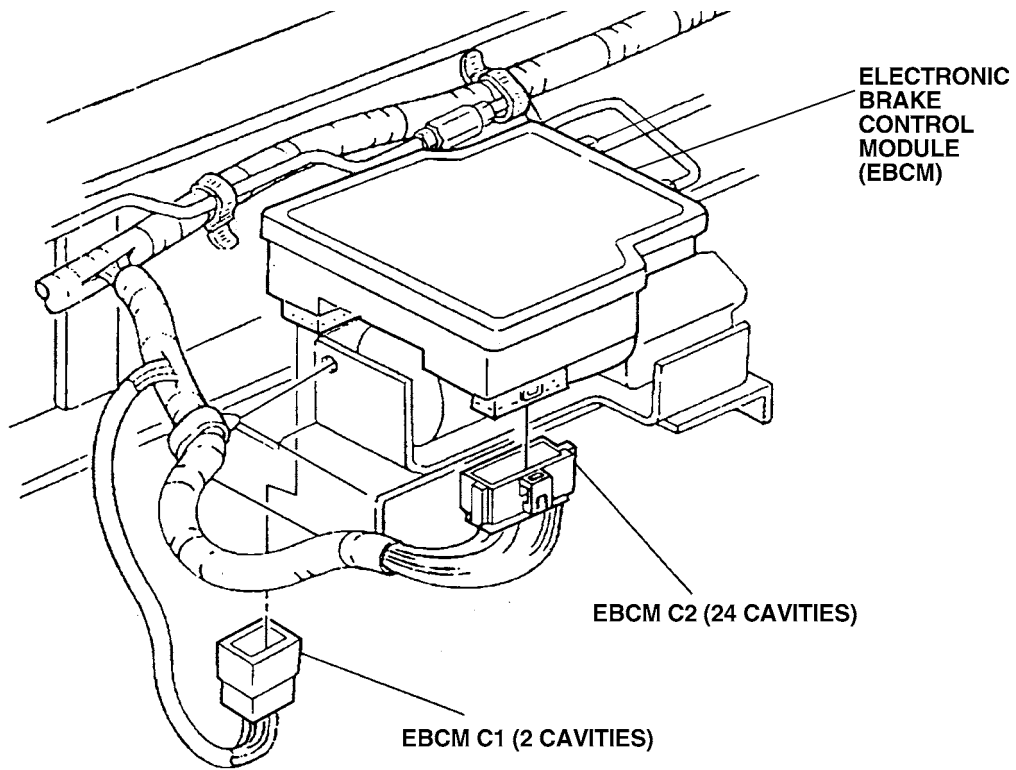
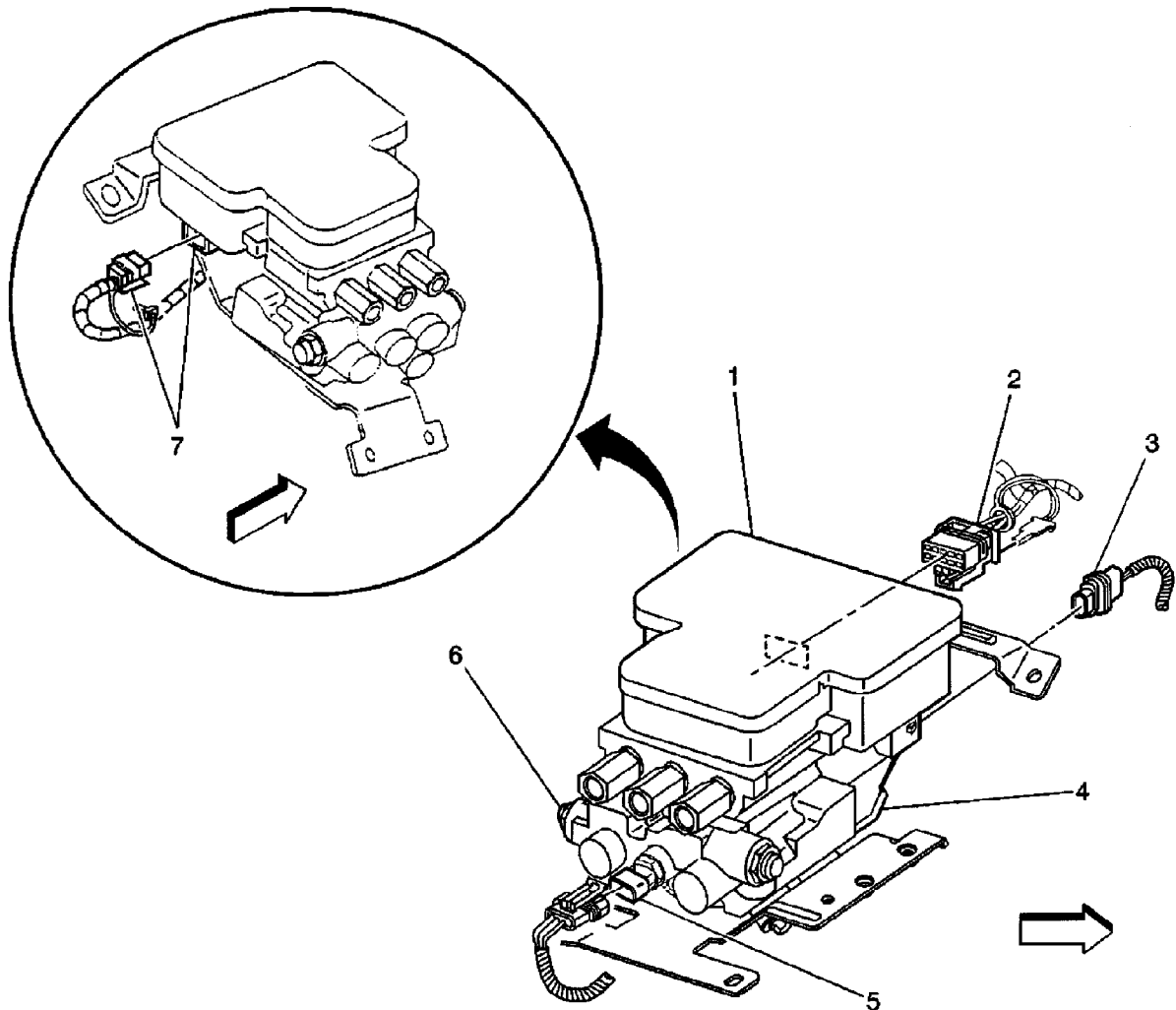

Figure G2019-10 Kelsey-Hayes ABS for a P-Chassis (Workhorse)



- 1— Electronic Brake Control Module (EBCM) (310)
- 2— Electronic Brake Control Module (EBCM) (310) Connector C1
- 3— Electronic Brake Control Module (EBCM) (310) Connector C3
- 4— Brake Pressure Modulator Valve
- 5— Brake Pressure Differential Switch
- 6— Combination Valve
- 7— Electronic Brake Control Module (EBCM) (310) Connector C2

Figure G2019-11 Kelsey-Hayes 310 ABS for 2000 S10 Blazer and Pickup