

#17

**SHOULD THE COIL FAIL ANY OF THESE STEPS, IT MUST BE REPLACED.**

1. COLD AND HOT PRIMARY AND SECONDARY READINGS MUST BE WITHIN SPECIFICATIONS.
2. LOOK FOR CORRODED OR DISCOLORED TERMINALS
3. LOOK FOR CARBON TRACK (BURNED) OR CRACKING ANYWHERE ON COIL.

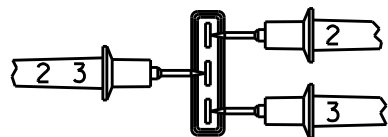
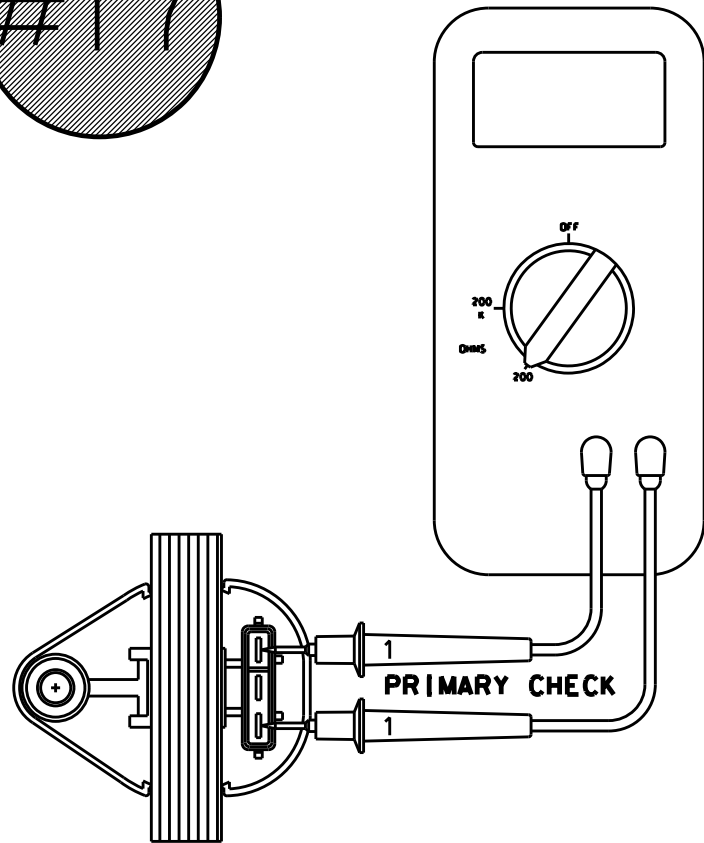

**PRIMARY CHECK  
C1215 ONLY**

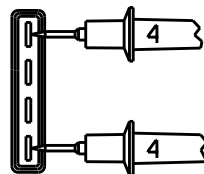

**PRIMARY CHECK  
C1202 ONLY**

