

Differential Carrier Final Assembly (Except Bravada)

Removal Procedure

1. Remove the 4 case bolts.
2. Remove the right carrier case half.
3. Clean the sealing surfaces on the carrier case halves. Remove all oil and grease using a chlorinated solvent, such as carburetor cleaner.

Installation Procedure

Tools Required

- J 8092 Driver Handle
- J 23911 Seal Installer
- J 33791 Bushing Remover and Installer Set
- J 33799 Shift Cable Housing Seal Installer
- J 33842 Pilot Bearing Installer
- J 42211 Bearing Installer

1. Apply a bead of sealer (GM P/N 1052357 or equivalent) to one carrier half mounting surface.
2. Assemble the carrier halves.

Notice: Refer to *Fastener Notice* in Cautions and Notices.

3. Install the carrier halves assembly bolts.

Tighten

Tighten the bolts to 50 N·m (37 lb ft).

4. Ensure that the sleeves are positioned properly, as previously marked.
5. Install the bolts and lock tabs.

Tighten

Tighten the bolts to 8 N·m (71 lb in).

6. Clean all oil and grease from the left cover and seal assembly, the bolts and the carrier sealing surfaces using carburetor cleaner or equivalent.

7. Apply sealer (GM P/N 1052357 or equivalent) to the cover.

8. Install the left cover and seal assembly.

Tighten

Tighten the bolts to 25 N·m (18 lb ft).

GM 12471587 "Carrier Cover"

Permatex-Anaerobic Flange Sealant, equivalent to GM 1052357 as per 2015 Permatex Master Products catalog

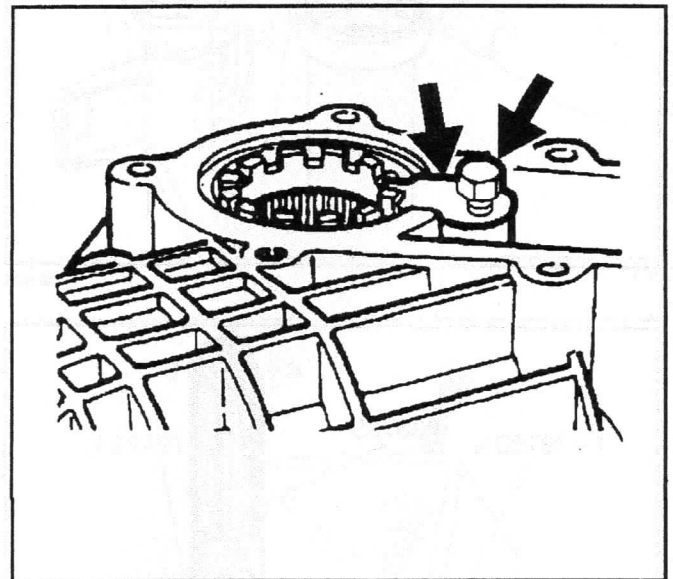

9031

9. Install the bearing using the *J 42211* and the *J 8092*.

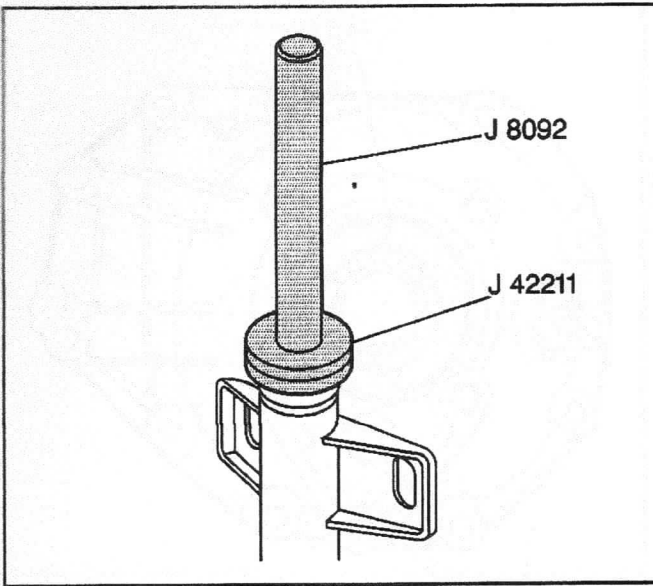

524680

10. Install the shaft seal using the *J 23911*.

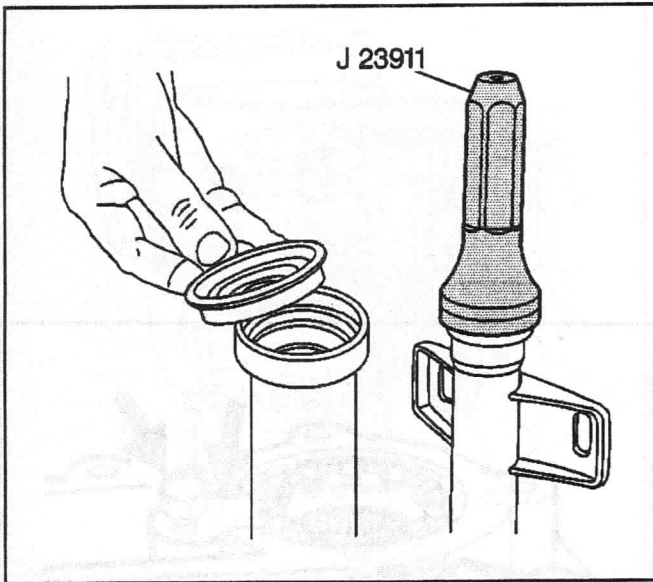

321864

11. Install the shift housing seal using the *J 33799*.

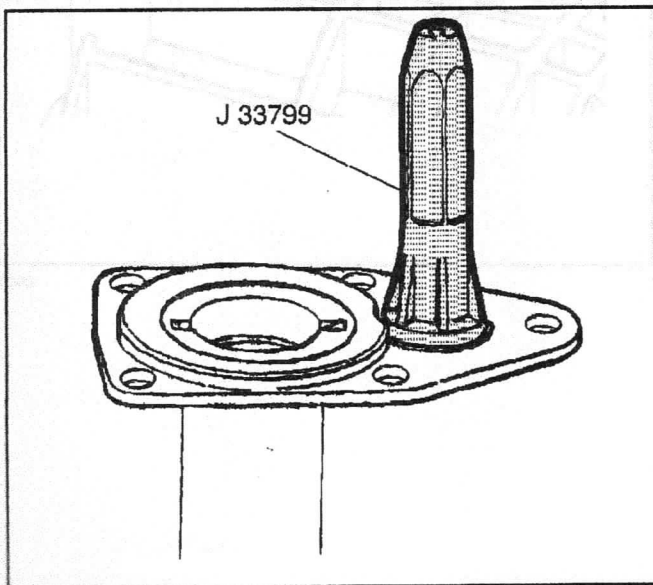

7795

12. Install the clutch shaft pilot bearing using the *J 33842*.
13. Install the washer to the clutch shaft.
14. Install the clutch shaft to the carrier assembly.
15. Install the clutch sleeve.
16. Install the thrust washer using grease in order to secure.
17. Install the spring with the shift shaft and fork.

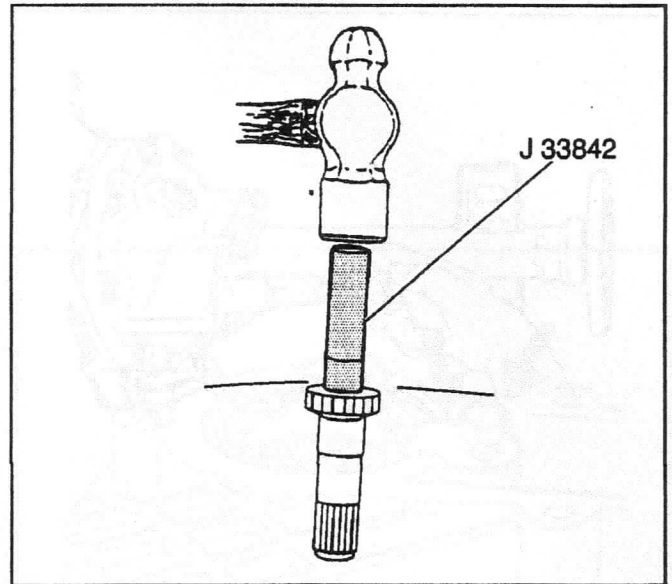

7796

18. Install the thrust washer using grease in order to secure. Align the notch and tab.
19. Install the inner axle shaft to the housing.
20. Install the clutch gear with the retaining ring. Tap into place.
 - 20.1. Remove all oil and grease from the housing flange to carrier gasket surfaces using carburetor cleaner or equivalent.
 - 20.2. Apply sealer (GM P/N 1052357 or equivalent) to the carrier.
21. Install the shaft and housing assembly to the carrier.
22. Install the two upper bolts finger-tight.
23. Install the shift cable housing and the remaining bolts.

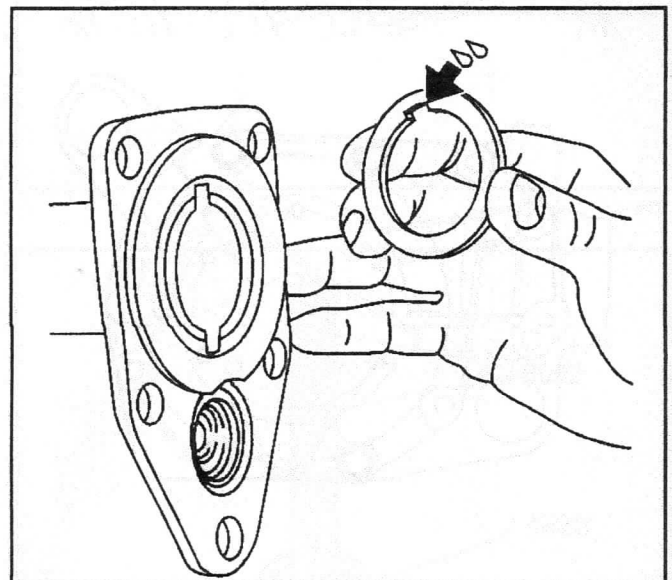

7797

Tighten

Tighten the five bolts to 48 N·m (36 lb ft).

24. Install the bushings using the *J 33791 -1*, the *J 33791-2* and the *J 33791-3*.

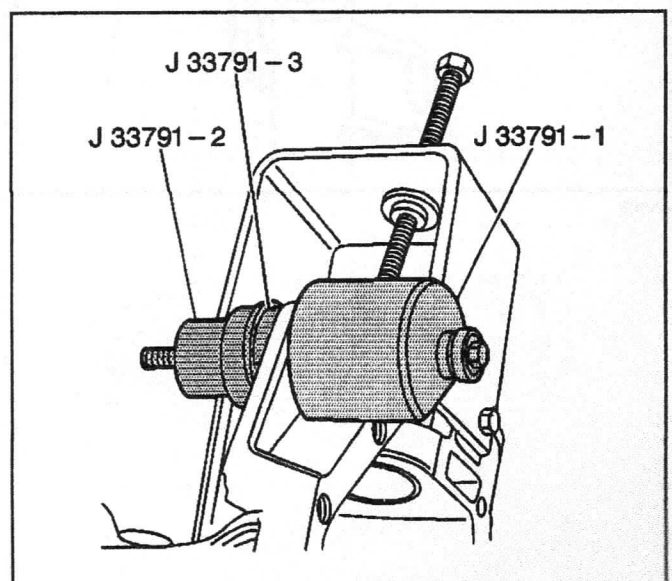

3095

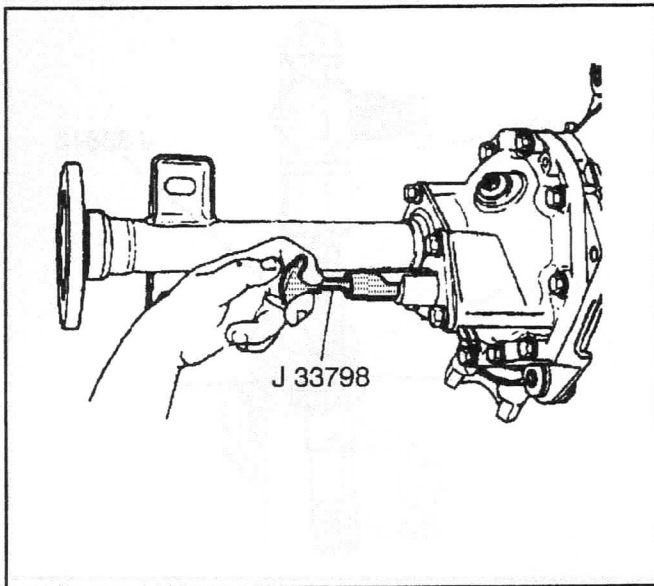

7798

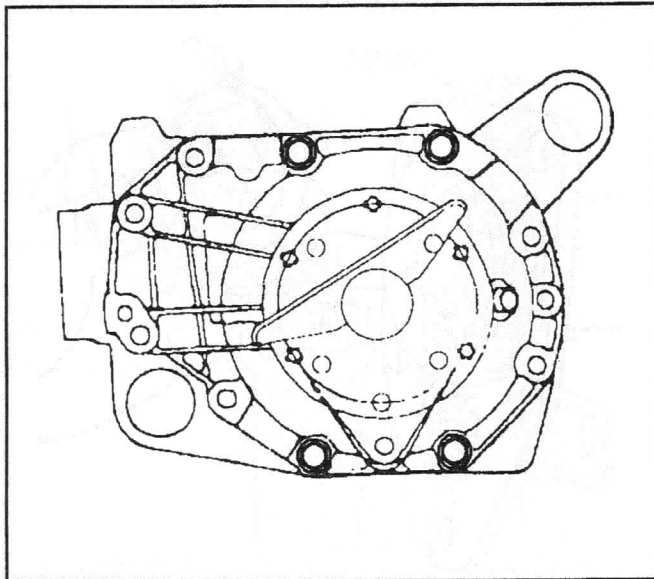

9352

Inspection Procedure

Tools Required

J 33798 Hub Engagement Tool

1. Inspect the operation of the shift mechanism. Insert the *J 33798* into the shift fork.
2. Turn the axle shaft while engaging and disengaging the shift mechanism with the tool.
3. The mechanism should operate smoothly. If not, remove the tube. Inspect for damaged or improperly installed parts.

Differential Carrier Final Assembly (Bravada)

Removal Procedure

1. Remove the four case bolts.
2. Remove the right carrier case half.
3. Clean the sealing surfaces on the carrier case halves. Remove all the oil and grease. Use a chlorinated solvent, such as carburetor cleaner.

Installation Procedure

Tools Required

- *J 8092* Driver Handle
- *J 23911* Seal Installer
- *J 33791* Bushing Remover and Installer Set
- *J 42211* Bearing Installer

1. Apply a bead of sealer (GM P/N 1052357 or equivalent) to one carrier half mounting surface. Follow the sealer manufacturer's instructions when applying the sealer.
2. Assemble the carrier halves.