

1996 AIR CONDITIONING & HEAT

MANUAL A/C

A/C SYSTEM SPECIFICATIONS**A/C SYSTEM SPECIFICATIONS**

Application	Specification
Compressor Type	
2.2L	Harrison V5 5-Cyl.
4.3L	Harrison HT6 6-Cyl.
Compressor Belt Tension	(1)
System Oil Capacity ⁽²⁾	
2.2L	9 ozs.
4.3L	8 ozs.
Refrigerant (R-134a) Capacity	32 ozs.
System Operating Pressures ⁽³⁾	
High Side	299 psi (21 kg/cm ²)
Low Side	26 psi (1.8 kg/cm ²)
(1) Tighten serpentine belt until indicator mark on movable portion of belt tensioner is within limits of slotted area on stationary portion of belt tensioner.	
(2) Use PAG Oil (Part No. 12345923).	
(3) Specification is with ambient temperature at 80°F (27°C), relative humidity at 60 percent and engine speed at 1500 RPM.	

DESCRIPTION

WARNING: To avoid injury from accidental air bag deployment, read and carefully follow all **SERVICE PRECAUTIONS** and **DISABLING & ACTIVATING AIR BAG SYSTEM** procedures in **AIR BAG** article in the **ACCESSORIES/SAFETY EQUIPMENT** Section.

CAUTION: When discharging air conditioning system, use only approved refrigerant recovery/recycling equipment. Make every attempt to avoid discharging refrigerant into the atmosphere.

SYSTEM DESCRIPTION

A/C-heater system is a blend-air system. Air entering vehicle must pass through evaporator core and through and/or around heater core to obtain desired temperature.

Compressor operation on 6-cylinder compressor is controlled by a pressure cycling switch located on top of accumulator. Compressor operation on 5-cylinder compressor is controlled by Powertrain Control Manual (PCM) through A/C compressor clutch relay based on A/C related inputs to PCM.

OPERATION

A/C-HEATER CONTROL PANEL

Temperature Control Knob

An electric motor controls the temperature door based on the temperature knob position. When temperature knob is in the Blue (cold) position, air delivered by system is unheated. When temperature knob is in Red (hot) position, all air passing through heater module is heated before it is discharged. Intermediate position of temperature knob results in a mixture of heated and unheated air to provide more moderate air temperatures.

Mode Selector Knob

Mode selector knob positions are OFF, MAX A/C, NORM A/C, BI-LEV A/C, VENT, HEAT, BLEND and DEFROST. Mode selector knob operates a rotary vacuum switch that routes engine vacuum to specific hoses in the vacuum harness. These hoses control various vacuum actuators on A/C-heater system. Each actuator operates an air valve (a door-like hinged deflector) that routes airflow to various outlets through the system.

Blower Switch

Blower switch provides a choice of various blower speeds. Blower switch receives power through a fuse in fuse block when ignition is on. In various speed positions, circuit continues through wiring harness to blower motor resistor, near blower motor. There are 4-positions: LO, HI and 2 intermediate positions. Blower operates in any mode position except OFF.

TROUBLE SHOOTING

WARNING: To avoid injury from accidental air bag deployment, read and carefully follow all **SERVICE PRECAUTIONS** and **DISABLING & ACTIVATING AIR BAG SYSTEM** procedures in the article, **AIR BAG RESTRAINT SYSTEM**, in the **ACCESSORIES/SAFETY EQUIPMENT** section

NOTE: Also see **A/C-HEATER SYSTEM TROUBLE SHOOTING - MANUAL article.**

A/C COMPRESSOR CLUTCH CONTROLS

See **A/C COMPRESSOR CLUTCH CONTROLS** article.

BLOWER MOTOR INOPERATIVE

1. Turn ignition switch to RUN position. Place mode selector in VENT position. Place blower switch in LO position. Connect test light from Purple wire at blower motor relay connector to ground. If test light does not glow, go to next step. If test light glows, check for poor connection at blower motor and relay connectors. If connections are okay, check for open Purple wire or Black wire between blower motor relay connector and blower motor connector. If wires are okay, replace blower motor.
2. Disconnect blower motor relay connector. Connect test light from Dark Blue wire at blower motor relay connector to ground. If test light does not glow, go to next step. If test light glows, check for poor connection at blower motor relay connector. If connection is okay, replace blower motor relay.
3. Connect test light from Brown wire (mode selector control to fuse block wire) at mode selector control to ground. If test light does not glow, repair open Brown wire between mode selector control and fuse block. If test light glows, check for poor connections at blower motor relay connector and mode selector control connector. If connections are okay, replace control panel.

BLOWER MOTOR DOES NOT OPERATE IN HIGH SPEED

1. Turn ignition switch to RUN position. Place mode selector in VENT position. Place blower switch in HIGH position. Connect test light from Orange wire at blower motor relay connector to ground. If test light glows, go to next step. If test light does not glow, check for poor connection at blower switch connector of control panel. If connection is okay, replace control panel.
2. Connect test light from Red wire at blower motor relay connector to ground. If test light does not glow, repair open Red wire between blower motor relay connector and battery junction block. If test light glows, check for poor connection at blower motor relay connector or open Black wire between blower motor relay connector and ground. If connection and wire are okay, replace blower motor relay.

BLOWER MOTOR DOES NOT OPERATE IN MEDIUM SPEEDS

1. Turn ignition switch to RUN position. Place mode selector in VENT position. Place blower switch in medium-low (M1) position. Connect test light from Tan wire at blower motor resistor connector to ground. If test light glows, go to next step. If test light does

not glow, check for poor connection at blower switch connector of control panel or open Tan wire. If connection and wire are okay, replace control panel.

2. Place blower switch in medium-high (M2) position. Connect test light from Light Blue wire at blower motor resistor connector to ground. If test light does not glow, check for poor connection at blower switch connector or open Light Blue wire. If connection and wire are okay, replace blower switch. If test light glows, check for poor connection at blower motor resistor connector. If connection is okay, replace blower motor resistor.

BLOWER MOTOR DOES NOT OPERATE IN LOW SPEED

Turn ignition switch to RUN position. Place mode selector in VENT position. Place blower switch in LO position. Disconnect blower motor resistor. Connect test light from Brown wire at blower motor resistor connector to ground. If test light does not glow, check Brown wire for high resistance or open. If wire is okay, replace control panel. If test light glows, check for poor connections at blower motor resistor. If connections are okay, replace blower motor resistor.

BLOWER MOTOR OPERATES IN HIGH SPEED ONLY

1. Turn ignition switch to RUN position. Place mode selector in VENT position. Place blower switch in LO position. Using a DVOM, measure voltage between Dark Blue wire at blower motor relay connector and ground. If voltage is less than 4 volts, go to next step. If voltage is greater than 4 volts, check for poor connection at blower motor relay connector. If connection is okay, replace blower motor relay.
2. Disconnect blower motor resistor connector. Connect test light from Brown wire at blower motor resistor connector to ground. If test light does not glow, check for open Brown wire or for poor connection at blower switch connector of control panel. If wire and connection are okay, replace control panel. If test light glows, check Dark Blue wire for high resistance or open. If wire is okay, replace blower motor resistor.

TESTING

A/C SYSTEM PERFORMANCE

1. Park vehicle out of direct sunlight. Open windows or door to ventilate interior. Vent engine exhaust, if necessary. Install manifold gauge set. Note ambient temperature and humidity.
2. Close all windows and doors. Place mode selector lever in MAX A/C position, blower switch lever in HIGH position, and temperature control lever in full cold position.
3. Insert thermometer into right center vent. Place transmission in Park or Neutral. Start engine and allow it to run at 1500 RPM until temperature tester reaches lowest temperature (approximately 3 minutes). See **A/C SYSTEM PERFORMANCE SPECIFICATIONS**.

A/C SYSTEM PERFORMANCE SPECIFICATIONS ⁽¹⁾

Ambient Temp. ° F (°C)	Low Side psi (kg/cm ²)	High Side psi (kg/cm ²)	Outlet Temp. °F (°C)
70 (21)	21 (1.5)	261 (18)	40 (4)
80 (27)	26 (1.8)	299 (21)	45 (7)
90 (32)	35 (2.5)	385 (27)	56 (13)

(1) Specifications are with relative humidity at 60 percent.

REMOVAL & INSTALLATION

WARNING: To avoid injury from accidental air bag deployment, read and carefully follow all **SERVICE PRECAUTIONS** and **DISABLING & ACTIVATING AIR BAG SYSTEM** procedures in the article, **AIR BAG RESTRAINT SYSTEM**, in the **ACCESSORIES/SAFETY EQUIPMENT** section

NOTE: For removal and installation procedures not covered in this article, see **HEATER SYSTEM** article.

ACCUMULATOR**Removal & Installation**

1. Disconnect negative battery cable. Discharge A/C system, using approved refrigerant recovery/recycling equipment. Disconnect electrical connections (if necessary). Disconnect accumulator lines, and plug openings. On 4.3L engines, remove accumulator bracket screws and accumulator. On 2.2L engines, remove clamp bolt remove accumulator from clamp. See **Fig. 1**.
2. To install, reverse removal procedure. Add 3.5 ounces of clean refrigerant oil to NEW accumulator before installation. Lubricate NEW "O" rings with clean refrigerant oil before installation. Evacuate, charge, and leak test system.

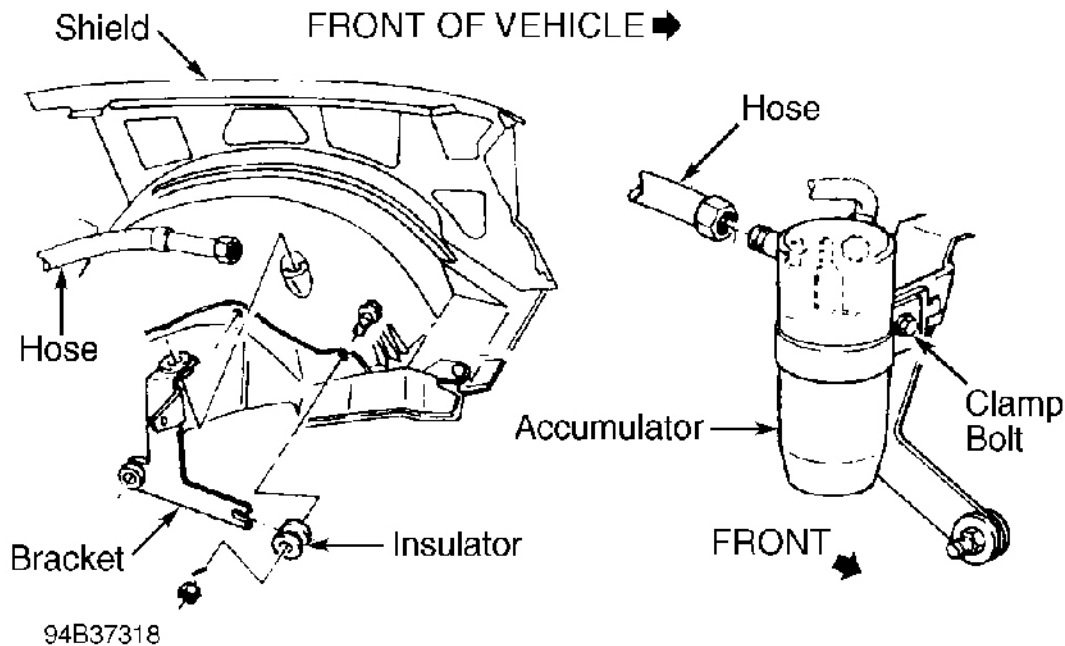
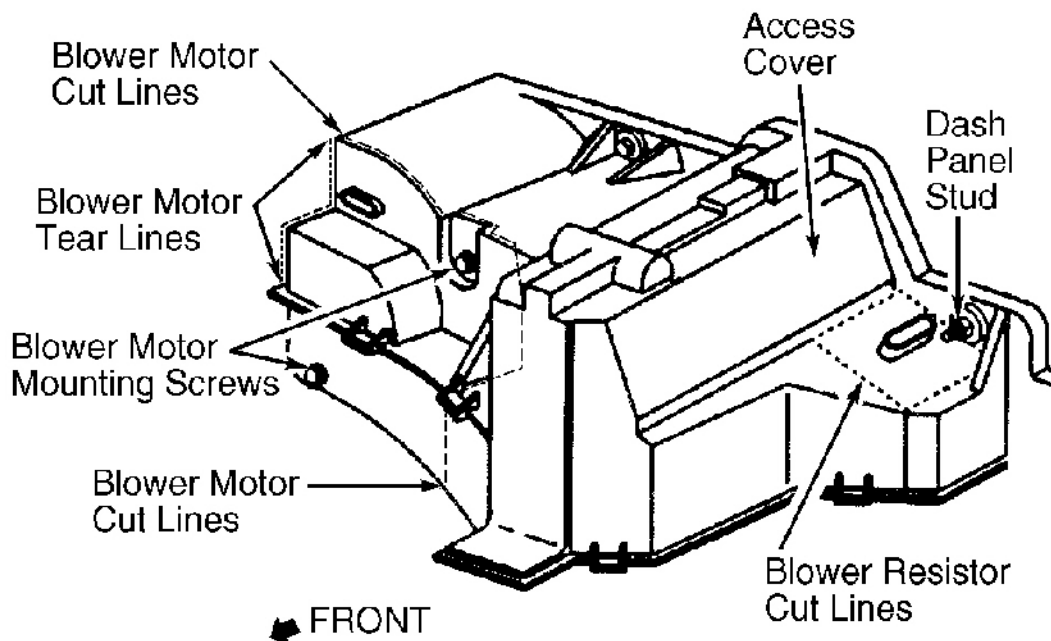

Fig. 1: Exploded View Of Accumulator Assembly
 Courtesy of GENERAL MOTORS CORP.

BLOWER MOTOR & FAN

Removal & Installation

1. Disconnect negative battery cable. Disconnect blower motor electrical connections. Remove Vehicle Control Module (VCM), if necessary. Remove coolant recovery reservoir and blower motor cooling tube. Remove blower motor mounting screws.
2. Cut access cover along dotted lines. See **Fig. 2**. Remove upper half of access cover, tearing remaining portion of access cover. Remove blower motor. Remove nut attaching blower fan to blower motor shaft, and remove fan.
3. To install, reverse removal procedure. Apply a bead of Black weatherstrip adhesive to cut and tear lines for access cover.



G95F60181

Fig. 2: Exploded View Of Blower Motor & Evaporator Assembly
 Courtesy of GENERAL MOTORS CORP.

COMPRESSOR

Removal & Installation

1. Disconnect negative battery cable. Discharge A/C system, using approved refrigerant recovery/recycling equipment. Remove electrical connections, as necessary.
2. Remove drive belt. Remove refrigerant hoses from compressor, and cap openings. Remove compressor from bracket (if equipped).
3. To install, reverse removal procedure. Drain and measure oil from old compressor. If less than one ounce is drained, add 2 ounces of refrigerant oil to NEW compressor. If more than one ounce is drained, add the same amount to NEW compressor. Evacuate, charge, and leak test system.

CONDENSER

Removal & Installation

1. Disconnect negative battery cable. Discharge A/C system, using approved refrigerant recovery/recycling equipment. Remove upper fan shroud. Drain engine coolant. Remove radiator. Disconnect inlet and outlet lines at condenser, and cap openings. Remove condenser from vehicle.

2. To install, reverse removal procedure. Lubricate NEW "O" rings with clean refrigerant oil before installation. Add one ounce of clean refrigerant oil to condenser. Fill cooling system, and check for leaks. Evacuate, charge, and leak test A/C system.

CONTROL PANEL

Removal & Installation

Disconnect negative battery cable. Remove instrument panel center bezel. Remove control panel screws. Remove control cable. Disconnect vacuum and electrical connectors at control panel. Remove control panel. To install, reverse removal procedure.

EVAPORATOR CORE

Removal & Installation

1. Disconnect negative battery cable. Discharge A/C system, using approved refrigerant recovery/recycling equipment. Remove A/C control relay and bracket and set aside. Remove blower motor resistor harness. Remove stud from dash panel above blower motor resistor.
2. Cut access cover along dotted lines. See **Fig. 2**. Remove 3 remove blower motor resistor retaining screws and remove blower motor resistor. Disconnect condenser-to-evaporator line. Remove hoses from accumulator. Remove accumulator. See **ACCUMULATOR**.
3. Remove evaporator and blower motor assembly screws and nuts. Remove evaporator and blower motor assembly. Remove case screws and nuts. Separate case halves, and remove evaporator core. See **Fig. 2**.
4. To install, reverse removal procedure. Lubricate NEW "O" rings with clean refrigerant oil before installation. Add 3 ounces of clean refrigerant oil to evaporator core. Apply a bead of Black weatherstrip adhesive to cut lines. Evacuate, charge, and leak test system.

HEATER CORE

CAUTION: Heater core can be damaged if too much force is applied to heater core pipes during hose removal.

Removal & Installation

1. Disable air bag system. See AIR BAG RESTRAINT SYSTEM article in the ACCESSORIES/SAFETY EQUIPMENT section. Drain engine coolant. Remove heater hoses at core, and plug core openings.
2. Remove instrument cluster trim plate. Move tilt steering column down (if equipped), set parking brake and move automatic transmission gear selector to low (if equipped).
3. Remove left underdash hush panel. Remove Data Link Connector (DLC) and Remote

Keyless Entry (RKE) module connectors. Remove center underdash hush panel.

Disconnect park brake release cable from instrument panel. Disconnect park brake cable from ratchet mechanism.

4. Remove right underdash hush panel. Remove lighter and accessory outlets, if equipped. Remove courtesy light. Remove knee bolster. Partially pull A/C-heater control panel and radio to disconnect connectors on back of A/C-heater control panel and radio.
5. Remove 4 steering column retaining bolts and lower steering column. Remove speaker and defroster grilles. Remove 9 instrument panel support bolts, including brake pedal bracket support bolt. See **Fig. 3**. Remove electrical connectors. Remove instrument panel.
6. Remove core cover attaching screws. Remove retainers at end of core. Remove heater core. To install, reverse removal procedure. Fill cooling system, and check for leaks.

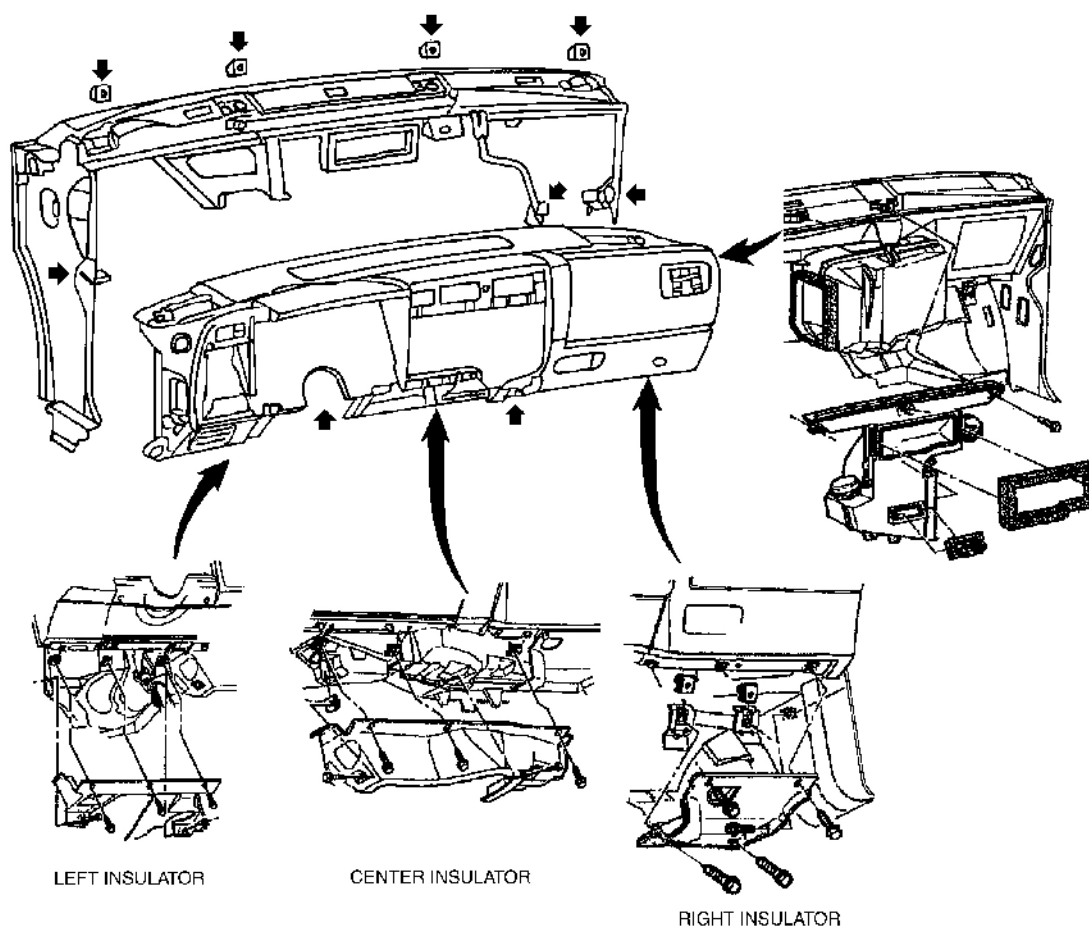

G63300182

Fig. 3: Locating Instrument Panel Support Bolts
Courtesy of GENERAL MOTORS CORP.

TORQUE SPECIFICATIONS

1996 Chevrolet Blazer**1996 AIR CONDITIONING & HEAT MANUAL A/C****TORQUE SPECIFICATIONS**

Application	Ft. Lbs. (N.m)
Accumulator Inlet Fitting	30 (41)
Compressor Bolts	
2.2L	37 (50)
4.3L	24 (33)
Compressor Hose Assembly Bolt ⁽¹⁾	24 (33)
Compressor-To-Bracket Bolt	23 (31)
Condenser Inlet Fitting	18 (24)
Evaporator-To-Accumulator Fitting	30 (41)
Evaporator-To-Condenser Line Fittings	13 (18)

(1) Use NEW sealing washers.

VACUUM DIAGRAM

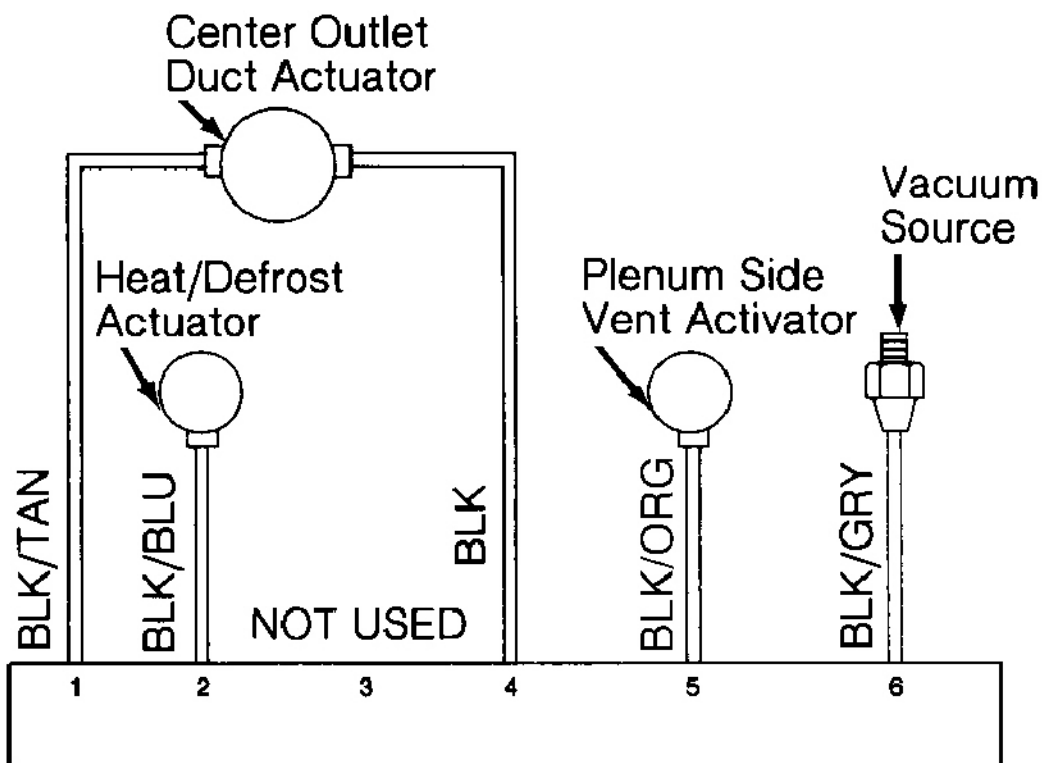

A/C - HEATER VACUUM SELECTOR VALVE OPERATING CHART

CONNECTION	PORT	OFF	MAX	NORM	BI-LEV	VENT	HTR	BLEND	DEF
DEFROST	1	VENT	VAC	VAC	VENT	VAC	VENT	VENT	VAC
A/C	2	VENT	VAC	VAC	VAC	VAC	VENT	VENT	VENT
NOT USED	3	VENT	VENT	VENT	VENT	VENT	VENT	VENT	VENT
HEAT	4	VAC	VENT	VENT	VENT	VENT	VAC	VENT	VENT
RECIRC	5	VENT	VAC	VENT	VENT	VENT	VENT	VENT	VENT
SOURCE	6	VAC	VAC	VAC	VAC	VAC	VAC	VAC	VAC

95H17654

Fig. 4: Manual A/C-Heater System Vacuum Diagram
 Courtesy of GENERAL MOTORS CORP.

WIRING DIAGRAMS

1996 Chevrolet Blazer

1996 AIR CONDITIONING & HEAT MANUAL A/C

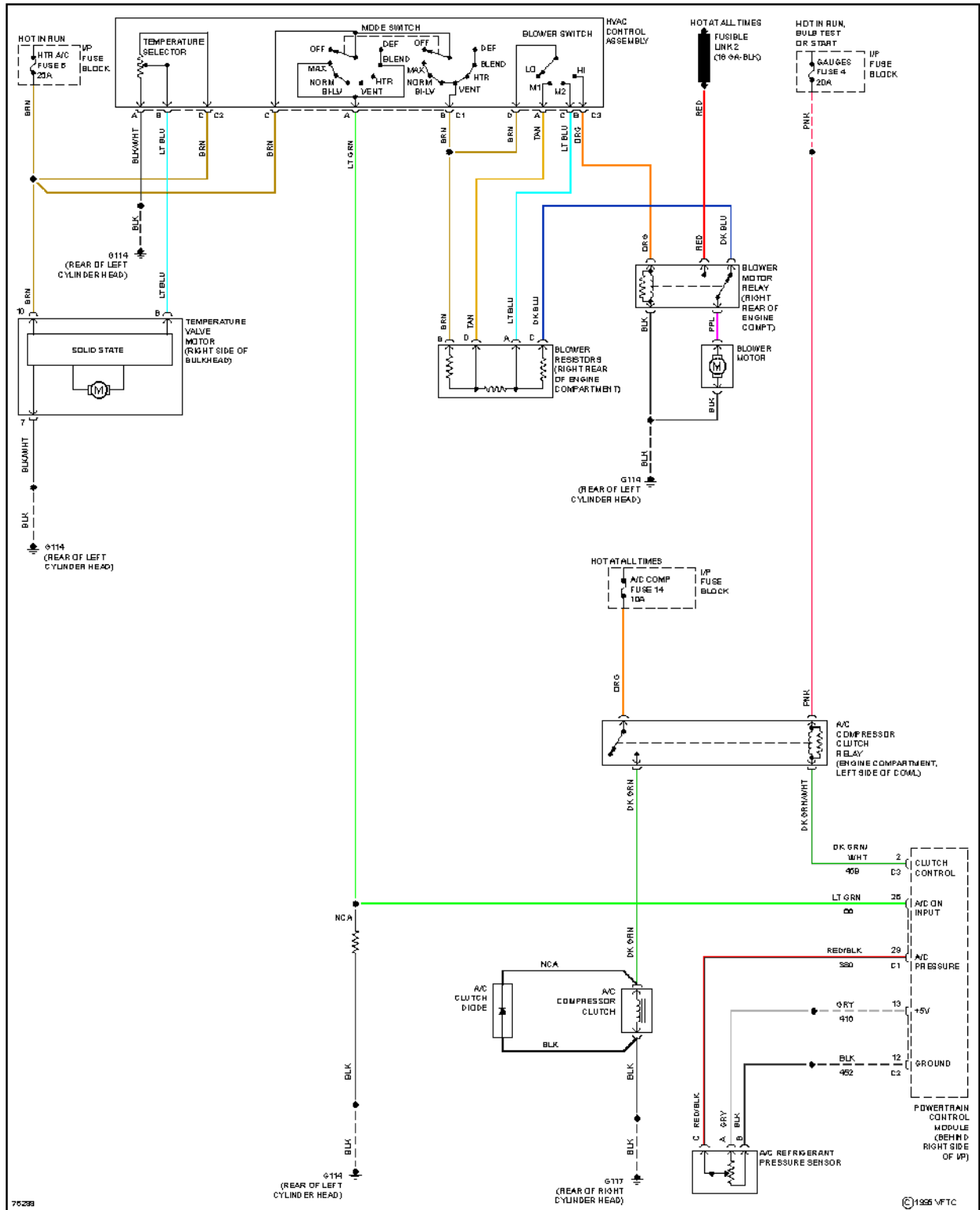

Fig. 5: Manual A/C-Heater System Wiring Diagram (2.2L)

1996 Chevrolet Blazer

1996 AIR CONDITIONING & HEAT MANUAL A/C

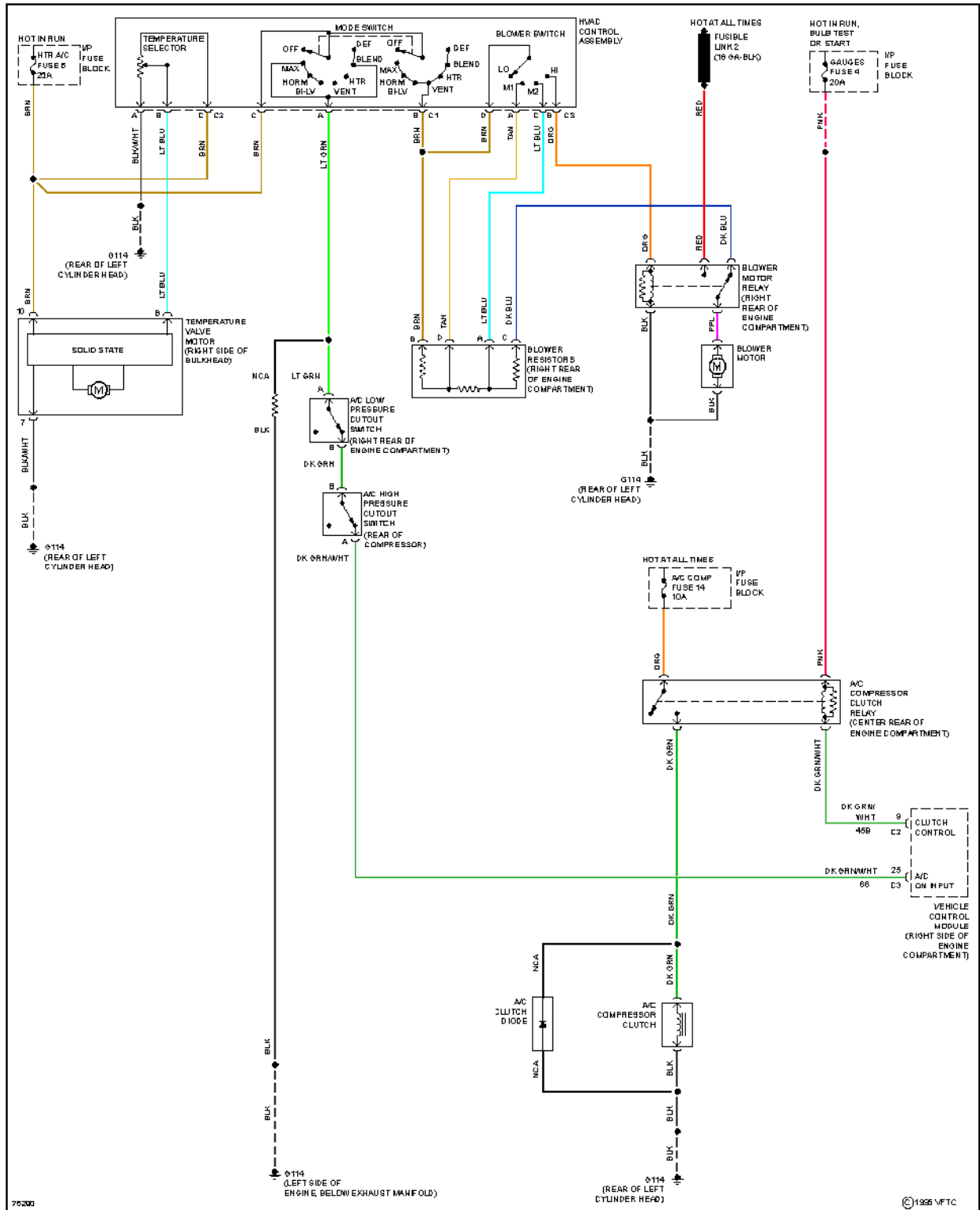

Fig. 6: Manual A/C-Heater System Wiring Diagram (4.3L)

1996 Chevrolet Blazer

1996 AIR CONDITIONING & HEAT MANUAL A/C

1996 Chevrolet Blazer

1996 AIR CONDITIONING & HEAT MANUAL A/C

1996 Chevrolet Blazer

1996 AIR CONDITIONING & HEAT MANUAL A/C