

<- Back

Forward ->

Document ID# 512238
2000 Chevrolet/Geo Blazer - 4WD

Print

Intake Manifold Replacement Upper

Removal Procedure

Important

The upper intake does not have to be removed to remove the lower intake manifold.

1. Remove the air cleaner outlet duct from the throttle body. Refer to [Air Cleaner Outlet Duct Replacement](#) In Engine Controls.
2. Disconnect the accelerator control cable from the throttle shaft and the accelerator cable bracket. Refer to [Accelerator Controls Cable Replacement](#) in Engine Controls.
3. Disconnect the cruise control cable, if equipped from the throttle shaft and the accelerator cable bracket. Refer to [Cruise Control Cable Replacement](#) in Cruise Control.

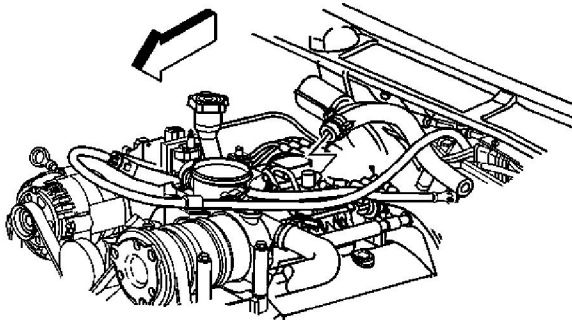

4. Disconnect the vacuum hose from the intake manifold for the vacuum tank.
5. Remove the power brake booster vacuum hose.

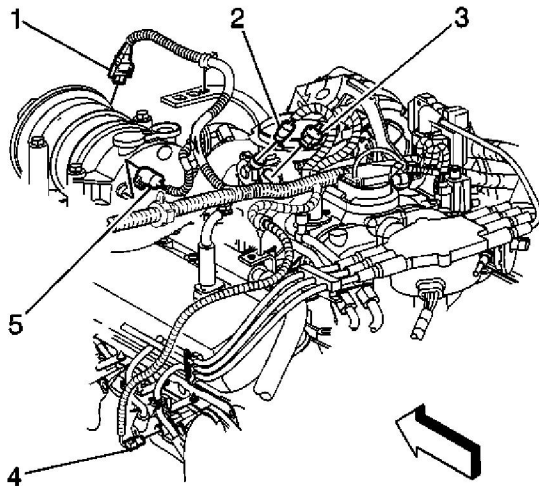

6. Disconnect the following electrical connectors:
- i The A/C compressor clutch (1)
 - i The A/C compressor cutoff switch (5), if equipped
 - i The throttle position (TP) sensor (2)
 - i The idle air control (IAC) motor (3)

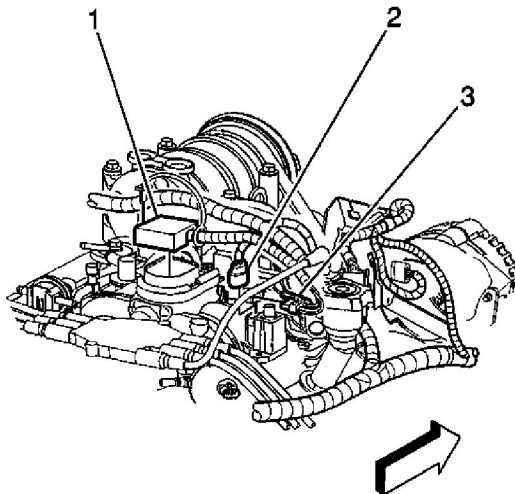

7. Disconnect the following electrical connectors:
- i The fuel meter body assembly (1)
 - i The manifold absolute pressure (MAP) sensor (3)
 - i The EVAP canister purge solenoid valve (2)
8. Remove the engine wire harness clip from the accelerator cable bracket.
9. Move the engine wiring harness aside.