

## Repair Instructions

### IP Service Precautions

#### Tools Required

- *J 35616-A* Connector Test Adapter Kit
- *J 39200* Digital Multimeter (DMM)
- Do not use a test lamp to diagnose the IPC electrical systems unless specifically instructed by the diagnostic procedure.
- Use the *J 35616-A* Connector Test Adapter when diagnostic procedures require the probing of connectors.
- The instrument panel cluster (IPC) will withstand normal current draws associated with vehicle operation.
- Avoid overloading any circuit.
- Do not ground or apply voltage to the IPC circuits unless instructed to do so when testing for opens or shorts.
- Circuits may only be tested using a *J 39200* Digital Multimeter or the equivalent.
- Test the electrical circuits with a *J 39200* DMM while the IPC connector remains connected to the IPC or the recommended breakout box.
- Do not remove or apply voltage to the IPC with the key in the RUN position.
- Always turn the key to the LOCK position before removing or connecting battery cables, fuses or connectors.
- Follow the removal and replacement instructions whenever you perform an IPC removal or replacement.

### IP Dimmer Switch Replacement

#### Removal Procedure

1. Ensure that the headlamp switch is OFF and that the ignition switch is in the LOCK position.
2. Remove the instrument panel accessory trim plate. Refer to *Trim Plate Replacement - IP Accessory*.
3. Disconnect the electrical connector.
4. Remove the screws that retain the headlamp switch panel to the instrument panel accessory trim plate.
5. Remove the headlamp switch panel from the instrument panel accessory trim plate.

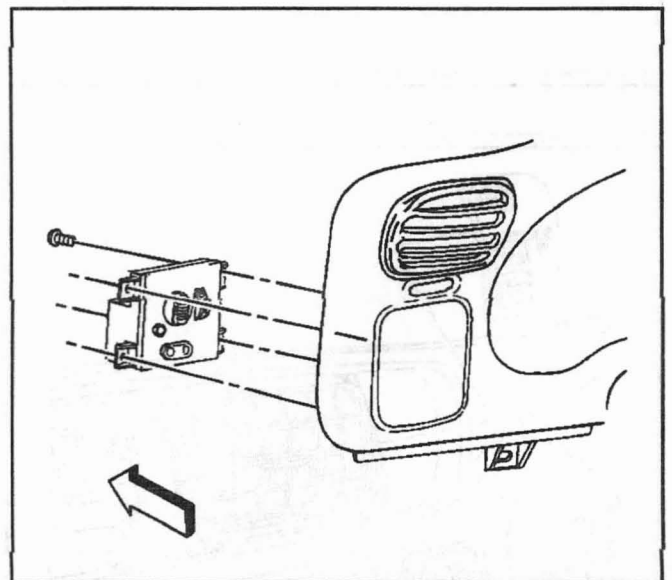

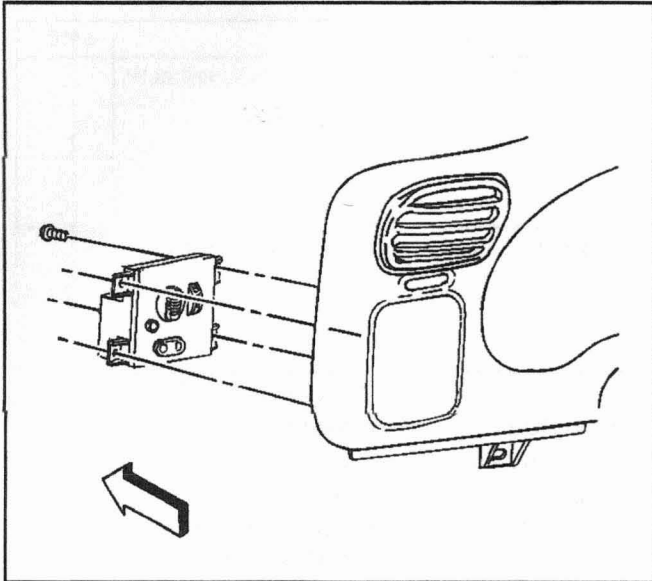

293825

### Installation Procedure

1. Install the headlamp switch panel to the instrument panel accessory trim plate.

**Notice:** Refer to *Fastener Notice* in Cautions and Notices.

2. Install the screws that retain the headlamp switch panel to the instrument cluster bezel.

#### Tighten

Tighten the screws to 1 N·m (9 lb in).

3. Connect the electrical connector.
4. Install the instrument panel accessory trim plate. Refer to *Trim Plate Replacement - IP Accessory*.

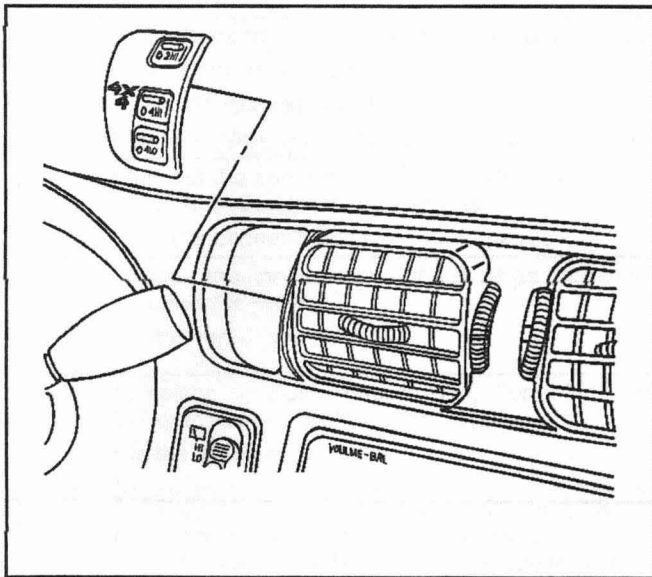

298997

### S4WD Select Switch Replacement

#### Removal Procedure

**Caution:** Refer to *Battery Disconnect Caution* in Cautions and Notices.

1. Disconnect the battery negative cable.
2. Remove instrument panel trim plate. Refer to *Trim Plate Replacement - IP Accessory*.
3. Disconnect the electrical connections as needed.
4. Release the locking tabs from the inside of the instrument panel trim plate in order to remove the switch.
5. Remove the switch from the trim plate.

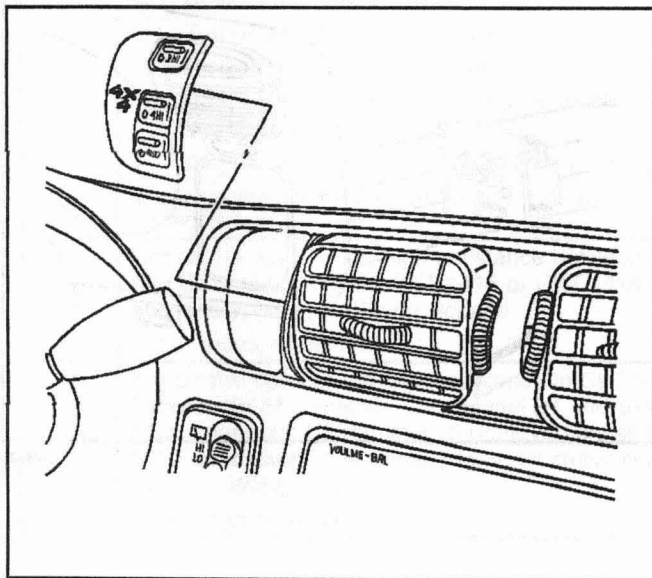

298997

#### Installation Procedure

1. Install the switch to the instrument panel trim plate with the locking tabs properly seated.
2. Connect the electrical connections as needed.
3. Install the instrument panel trim plate. Refer to *Trim Plate Replacement - IP Accessory*.
4. Connect the battery negative cable.

## Driver Information Center Module Replacement

### Removal Procedure

1. Using a flat-bladed tool, carefully pry the display lens (1) from the overhead console (3).
2. Remove the electronic display module (2) from the console (3).
3. Disconnect the electrical connection.

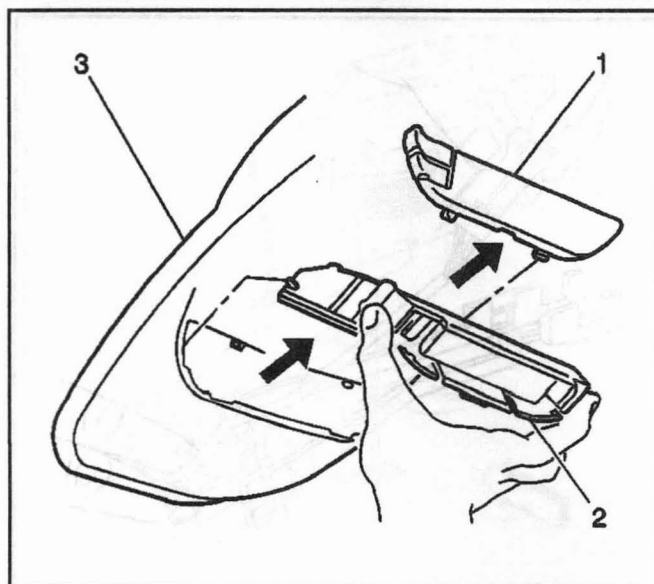

299158

### Installation Procedure

1. Connect the electrical connection.
2. Install the electronic display module (2) to the overhead console (3).
3. Install the display lens (1) by snapping the lens into place.
4. Calibrate the compass. Refer to *Electronic Compass Operation*.

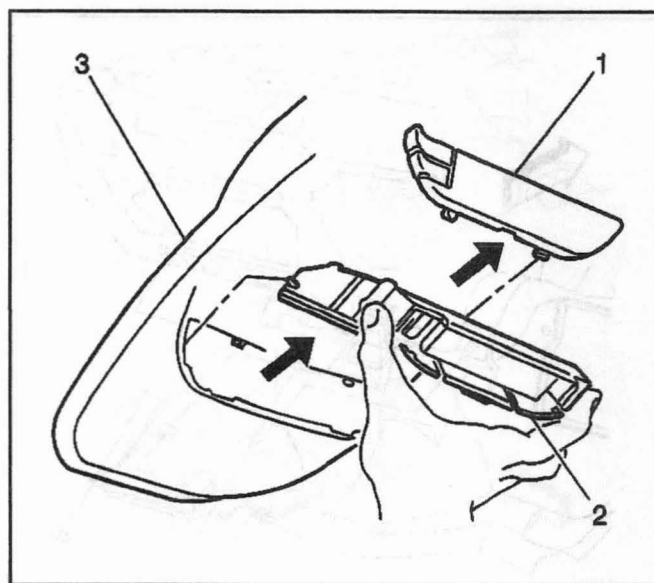

299158

## Electronic Compass Module Replacement

### Removal Procedure

Due to the complexity of the compass system and the extent of outside influences on the compass' performance, thoroughly inspect the system prior to performing repairs.

Inspect the compass in an area that is free from potential interference such as in an open field. Inspect that the compass is calibrated in order to verify the existence of a problem.

1. Remove the overhead console. Refer to *Driver Information Center Replacement (With Sunroof)*.
2. Remove the compass sensor from the overhead console.

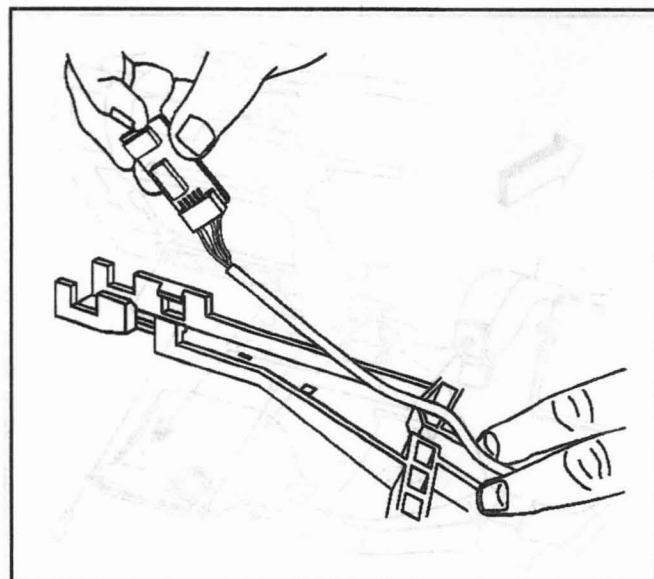

393033

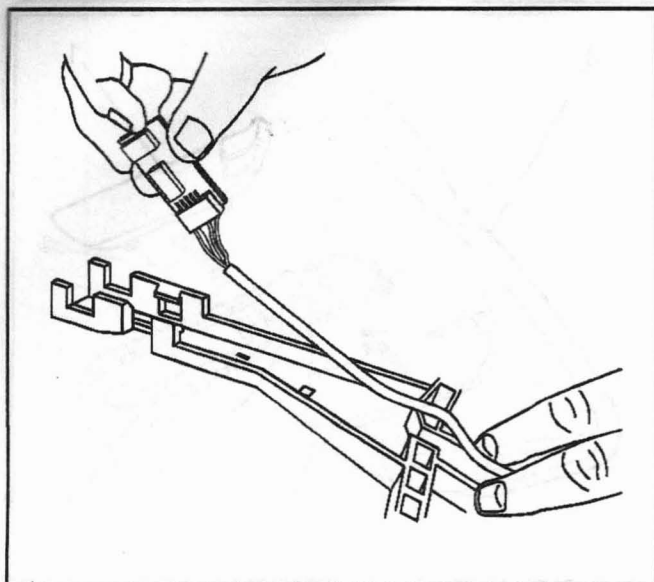

393033

### Installation Procedure

1. Install the compass sensor to the overhead console.
2. Install the overhead console. Refer to *Driver Information Center Replacement (With Sunroof)*.
3. Calibrate the compass. Refer to *Electronic Compass Operation*.

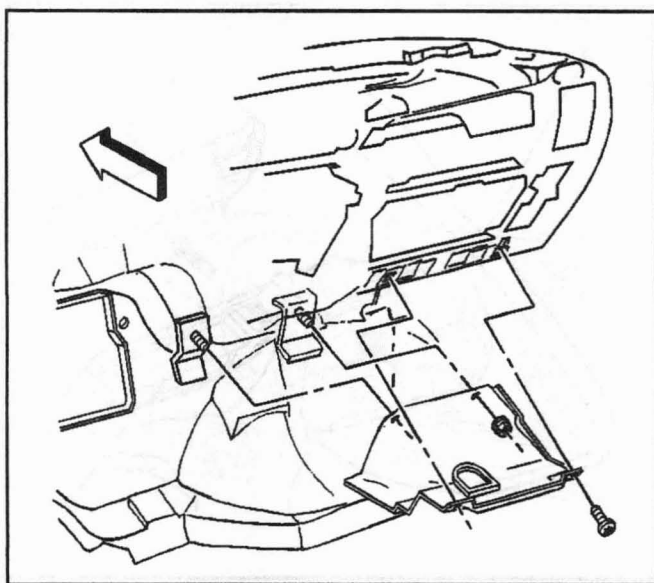

303360

### Closeout/Insulator Panel Replacement - Right

#### Removal Procedure

1. Remove the screws that retain the instrument panel sound insulator to the following components:
  - The instrument panel
  - The cowl
2. Remove the instrument panel sound insulator from the vehicle.

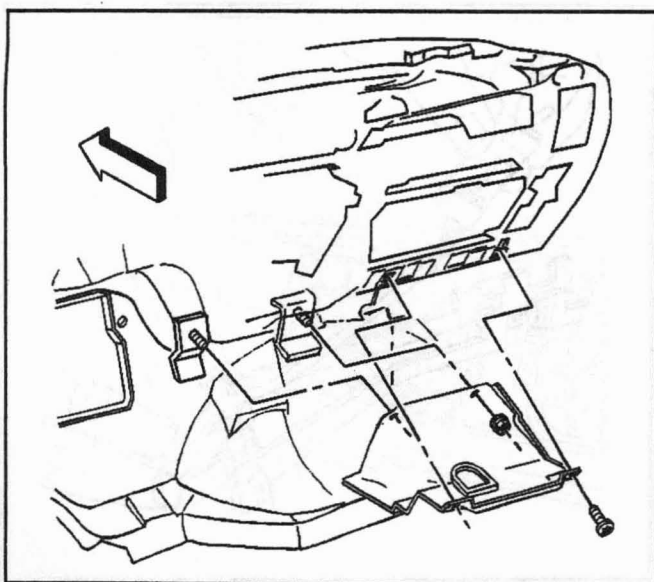

303360

#### Installation Procedure

1. Install the instrument panel sound insulator to the vehicle.

**Notice:** Refer to *Fastener Notice* in Cautions and Notices.

2. Install the screws that retain the instrument panel sound insulator to the following components:

- The instrument panel
- The cowl

#### Tighten

Tighten the screws to 1.9 N·m (17 lb in).

## Closeout/Insulator Panel Replacement - Left

### Removal Procedure

1. Remove the screws that retain the data link connector (DLC) to the instrument panel sound insulator.  
Feed the DLC lines through the hole in the sound insulator.
2. Remove the screws that retain the instrument panel sound insulator to the knee bolster and the cowl panel.
3. Disconnect the electrical connectors from the remote control door lock receiver module.
4. Remove and retain the remote control door lock receiver module from the instrument panel sound insulator (if equipped).

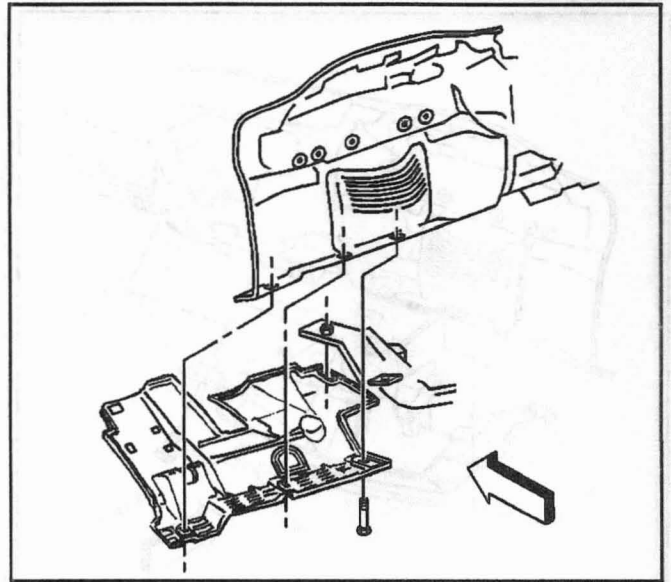

303358

### Installation Procedure

1. Install the remote control door lock receiver module to the instrument panel sound insulator.
2. Connect the electrical connector to the remote door lock receiver module.

**Notice:** Refer to *Fastener Notice* in Cautions and Notices.

3. Install the screw that retains the instrument panel sound insulator to the cowl panel.

#### Tighten

Tighten the screw to 1.9 N·m (17 lb in).

4. Install the screws that retain the instrument panel sound insulator to the knee bolster.

#### Tighten

Tighten the screws to 1.9 N·m (17 lb in).

5. Feed the DLC through the hole in the instrument panel sound insulator.

6. Install the screws that retain the DLC to the instrument panel sound insulator.

#### Tighten

Tighten the screws to 2.4 N·m (21 lb in).

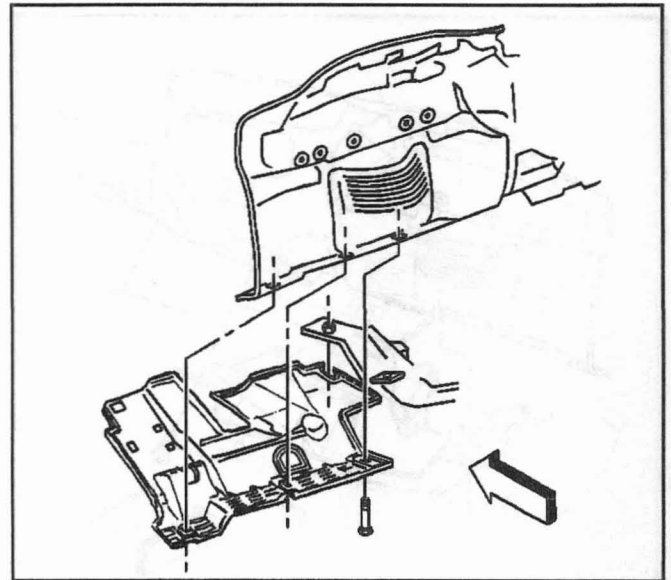

303358

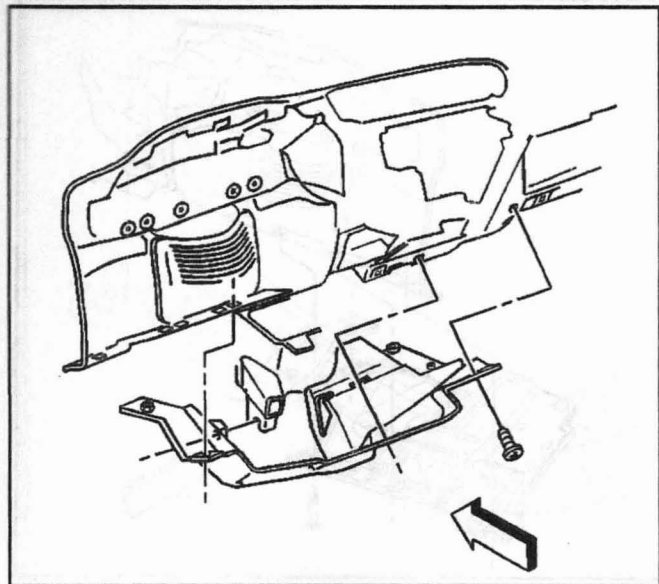

303359

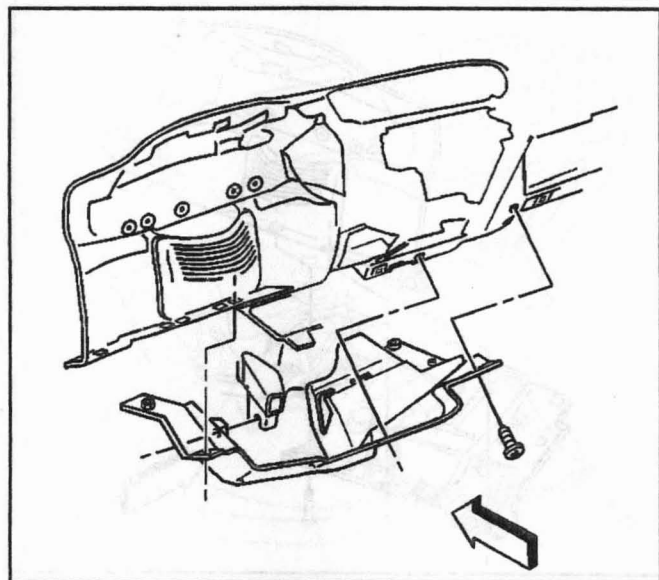

303359

## Closeout/Insulator Panel Replacement - Center

### Removal Procedure

1. Remove the center console from the vehicle if equipped with RPO code YC7 (GMC Envoy). Refer to *Console Replacement - Front Floor (Full Length (Envoy))*. 8-866
2. Remove the screws that retain the instrument panel sound insulator to the following components:
  - The knee bolster
  - The instrument panel
  - The heater assembly
  - The floor duct
3. Remove the instrument panel sound insulator from the vehicle.
4. Disconnect the electrical connector from the accessory power outlet (if equipped).

### Installation Procedure

1. Connect the electrical connector to the accessory power outlet (if equipped).
2. Install the instrument panel sound insulator to the vehicle.

**Notice:** Refer to *Fastener Notice* in Cautions and Notices.

3. Install the screws that retain the instrument panel sound insulator to the following components:
  - The knee bolster
  - The instrument panel
  - The floor duct.

#### Tighten

Tighten the screws to 1.5 N·m (13 lb in).

4. Install the screw that retains the instrument panel sound insulator to the heater assembly.

#### Tighten

Tighten the screw to 1.5 N·m (13 lb in).

5. Install the center console to the vehicle if equipped with RPO code YC7 (GMC Envoy). Refer to *Console Replacement - Front Floor (Full Length (Envoy))*.

## Trim Panel Replacement - Knee Bolster

### Removal Procedure

1. Set the park brake.
2. Block the wheels.
3. Remove the left-side instrument panel sound insulator. Refer to *Closeout/Insulator Panel Replacement - Left*.
4. Remove the center instrument panel sound insulator. Refer to *Closeout/Insulator Panel Replacement - Center*.
5. Release the park brake release cable from the park brake lever.
6. Remove the screw that retains the courtesy lamp to the knee bolster.
7. Remove the screws that retain the knee bolster to the instrument panel.
8. Remove the knee bolster from the vehicle.

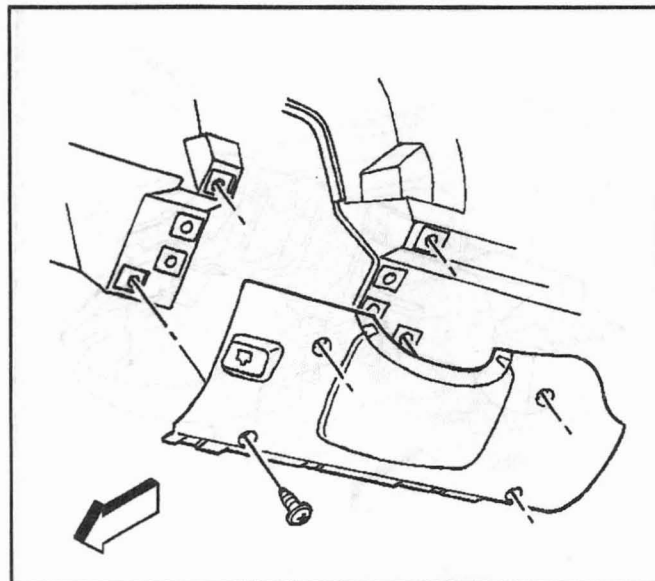

303362

### Installation Procedure

1. Install the knee bolster to the vehicle.

**Notice:** Refer to *Fastener Notice* in Cautions and Notices.

2. Install the screws that retain the knee bolster to the instrument panel.

#### Tighten

- Tighten the Torx® screws to 9 N·m (80 lb in).
- Tighten the hex head screws to 1.9 N·m (17 lb in).

3. Install the park brake release cable to the park brake lever.
4. Install the center instrument panel sound insulator. Refer to *Closeout/Insulator Panel Replacement - Center*.
5. Install the left-side instrument panel sound insulator. Refer to *Closeout/Insulator Panel Replacement - Left*.

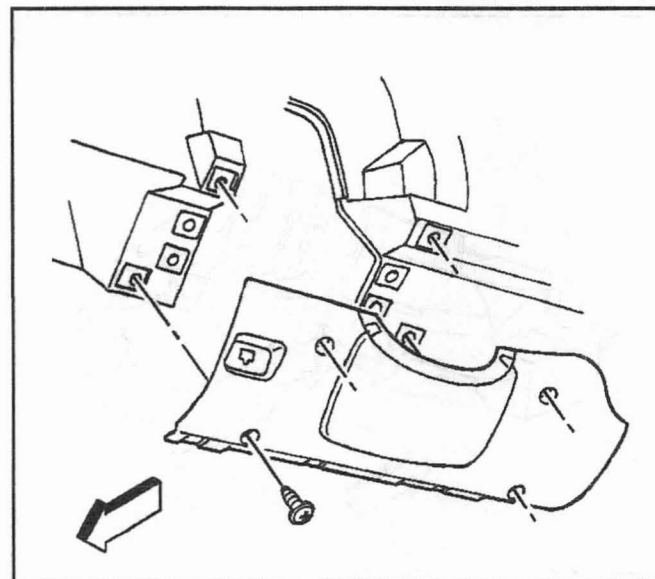

303362

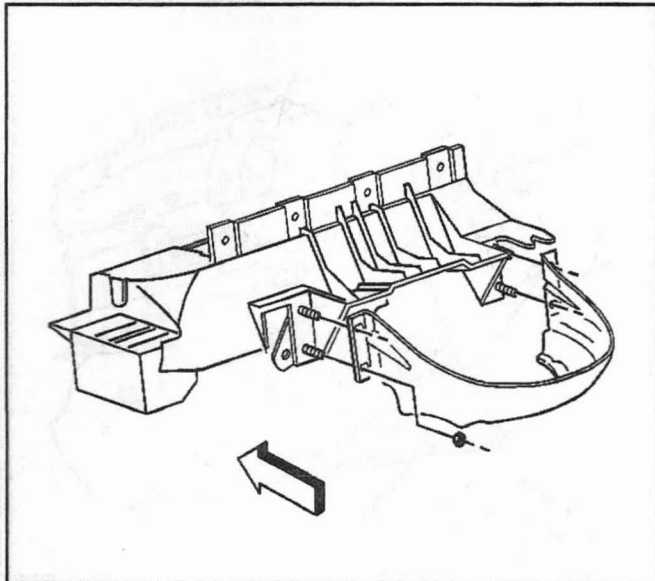

303365

## Knee Bolster Replacement

### Removal Procedure

1. Turn the ignition switch to the LOCK position.
2. Remove the left sound insulator. Refer to *Closeout/Insulator Panel Replacement - Left*.
3. Remove the knee bolster trim panel. Refer to *Trim Panel Replacement - Knee Bolster*.
4. Remove the instrument panel accessory trim plate. Refer to *Trim Plate Replacement - IP Accessory*.
5. Remove the nuts that retain the knee bolster from the steering column support.
6. Remove the knee bolster from the studs.

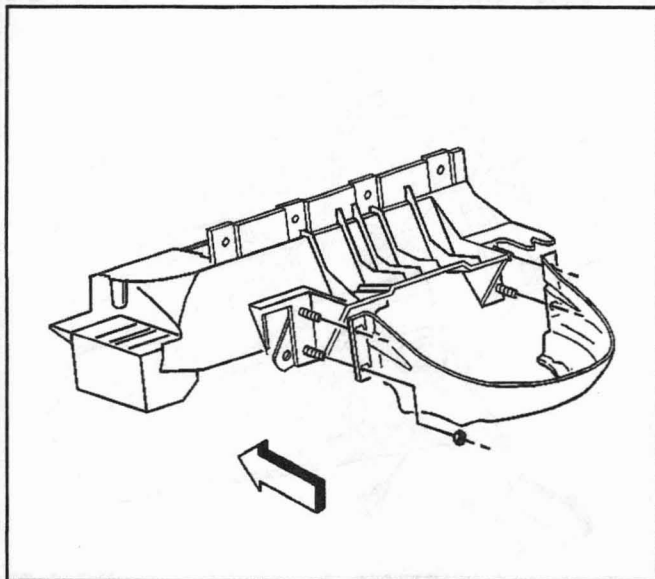

303365

### Installation Procedure

1. Install the knee bolster to the studs.
- Notice:** Refer to *Fastener Notice* in Cautions and Notices.
2. Install the nuts that retain the knee bolster to the steering column support.

#### Tighten

Tighten the nuts to 10 N·m (89 lb in).

3. Install the instrument panel accessory trim plate. Refer to *Trim Plate Replacement - IP Accessory*.
4. Install the knee bolster trim panel. Refer to *Trim Panel Replacement - Knee Bolster*.
5. Install the left sound insulator. Refer to *Closeout/Insulator Panel Replacement - Left*.

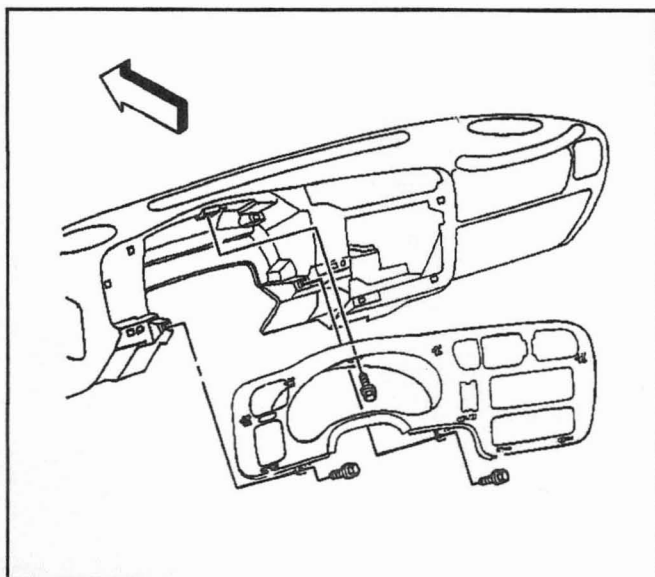

303364

## Trim Plate Replacement - IP Accessory

### Removal Procedure

1. Remove the left instrument panel sound insulator. Refer to *Closeout/Insulator Panel Replacement - Left*.
2. Remove the knee bolster trim panel. Refer to *Trim Panel Replacement - Knee Bolster*.
3. Remove the screws that retain the instrument panel accessory trim plate to the instrument panel.
4. Remove the instrument panel accessory trim plate.
5. Disconnect the electrical connectors, as needed.
6. Remove and retain the control switches.

**Installation Procedure**

1. Install the control switches.
2. Connect the electrical connectors, as needed.
3. Install the instrument panel accessory trim plate.

**Notice:** Refer to *Fastener Notice* in Cautions and Notices.

4. Install the screws that retain the instrument panel accessory trim plate to the instrument panel.

**Tighten**

Tighten the screws to 1.9 N·m (17 lb in).

5. Install the knee bolster trim panel. Refer to *Trim Panel Replacement - Knee Bolster*.
6. Install the left instrument panel sound insulator. Refer to *Closeout/Insulator Panel Replacement - Left*.

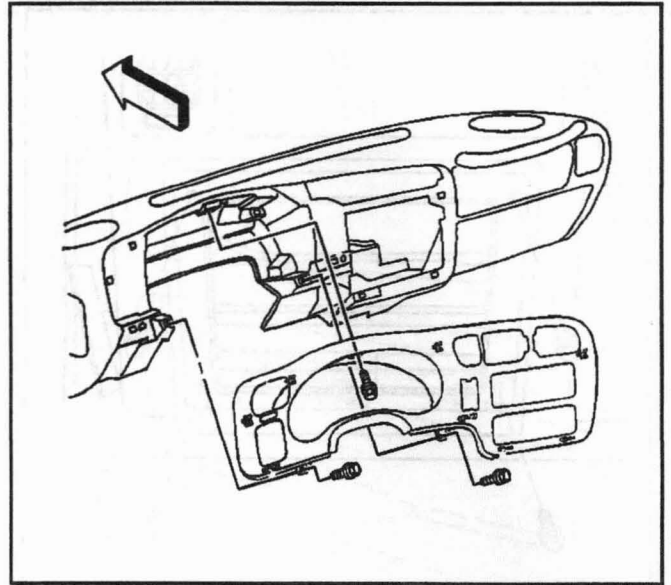

303364

**Door Replacement - IP Storage Compartment Door**

**Removal Procedure**

1. Remove the right side instrument panel sound insulator. Refer to *Closeout/Insulator Panel Replacement - Right*.
2. Push up on the J-spring in order to release the storage compartment door.

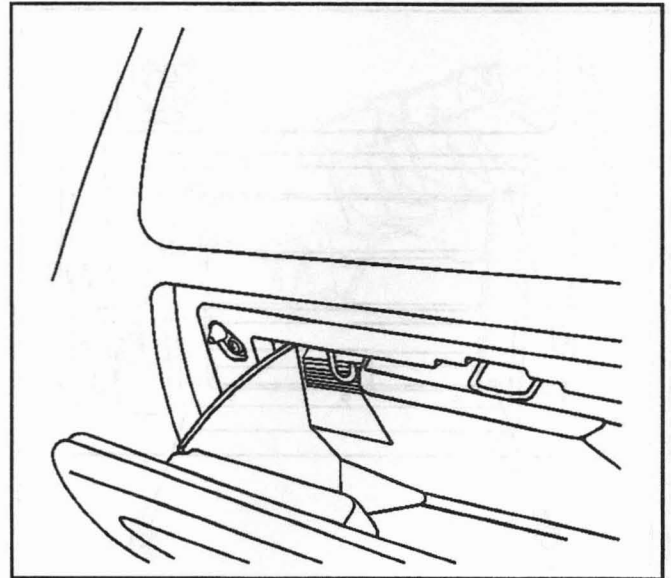

313447

3. Remove the screws that retain the instrument panel compartment door hinges to the instrument panel.
4. Remove the instrument panel storage compartment door from the instrument panel.

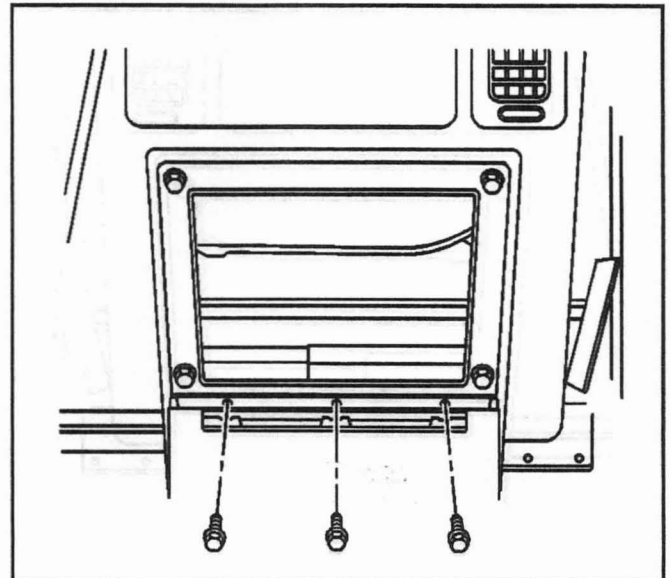

392772

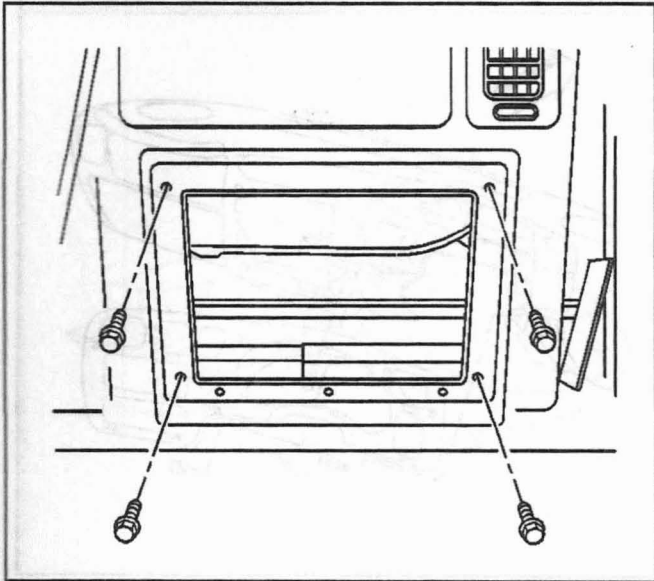

392773

5. Remove the screws that retain the instrument panel compartment bezel to the instrument panel.
6. Remove the instrument panel compartment bezel from the instrument panel.
7. Disconnect the electrical connector from the instrument panel compartment lamp and switch assembly.

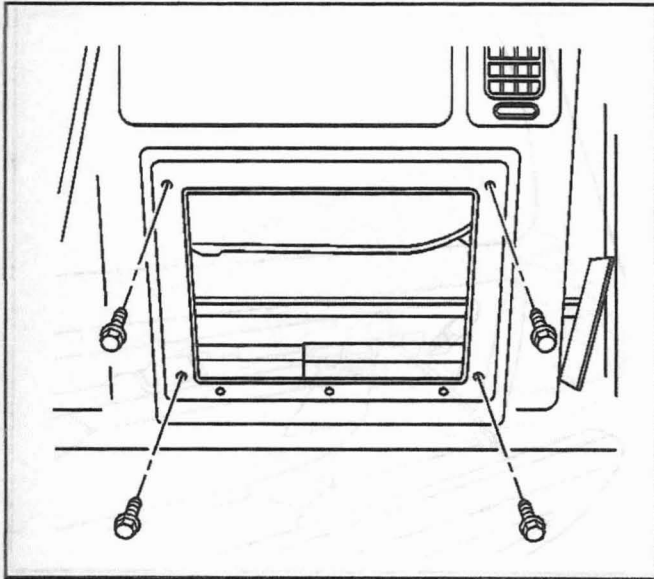

392773

### Installation Procedure

1. Connect the electrical connector to the instrument panel compartment lamp and switch assembly.
2. Install the storage compartment bezel to the instrument panel.

**Notice:** Refer to *Fastener Notice* in Cautions and Notices.

3. Install the screws that retain the instrument panel compartment bezel to the instrument panel.

#### Tighten

Tighten the screws to 1.9 N·m (17 lb in).

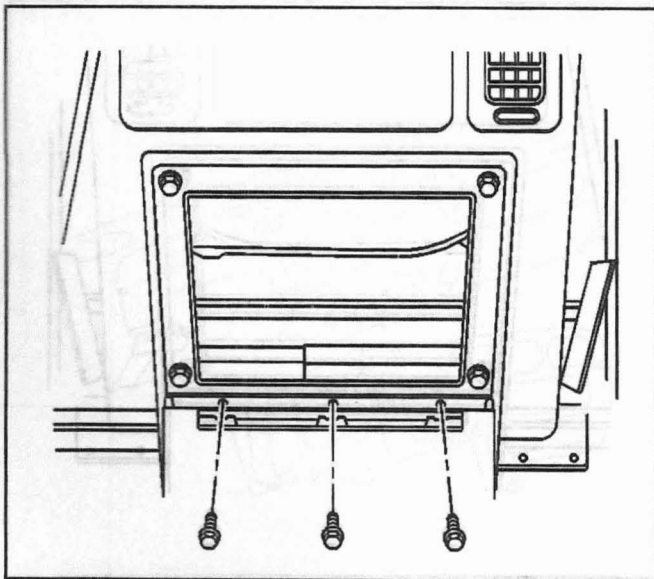

392772

4. Install the instrument panel storage compartment door to the instrument panel.
5. Install the screws that retain the instrument panel compartment door hinges to the instrument panel.

#### Tighten

Tighten the screws to 1.9 N·m (17 lb in).

6. Push the storage compartment into place.
7. Install the right side instrument panel sound insulator. Refer to *Closeout/Insulator Panel Replacement - Right*.

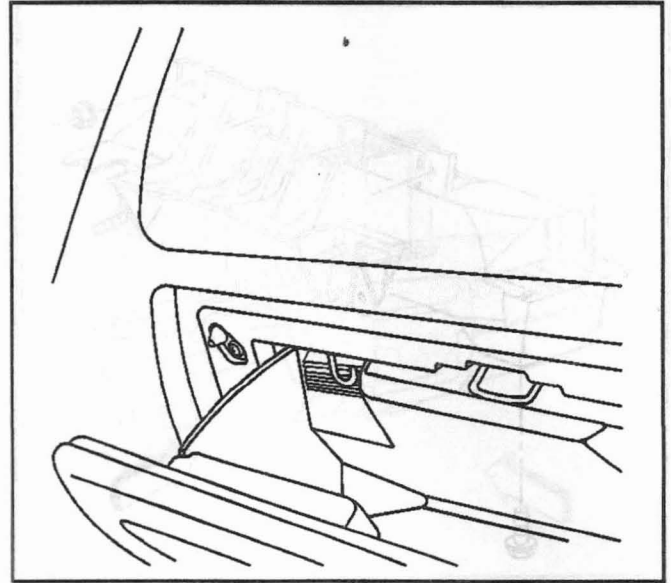

313447

### Bracket Replacement - Steering Column

#### Removal Procedure

**Important:** The steering column support is not serviceable.

1. Remove the instrument panel. Refer to *IP Carrier Replacement*.
2. Remove the brake switch. Refer to *Stoplamp Switch Replacement* in Hydraulic Brakes.
3. Remove the brake booster pushrod from the brake pedal. Refer to *Vacuum Brake Booster Replacement* in Hydraulic Brakes.
4. Remove the clutch master cylinder pushrod from the clutch pedal, if equipped. Refer to *Clutch Pedal Replacement* in Clutch.
5. Remove the following steering column support fasteners:
  - The 4 flange nuts
  - The 2 bolts
6. Remove the brake pedal from the steering column support. Refer to *Brake Pedal Replacement* in Hydraulic Brakes.

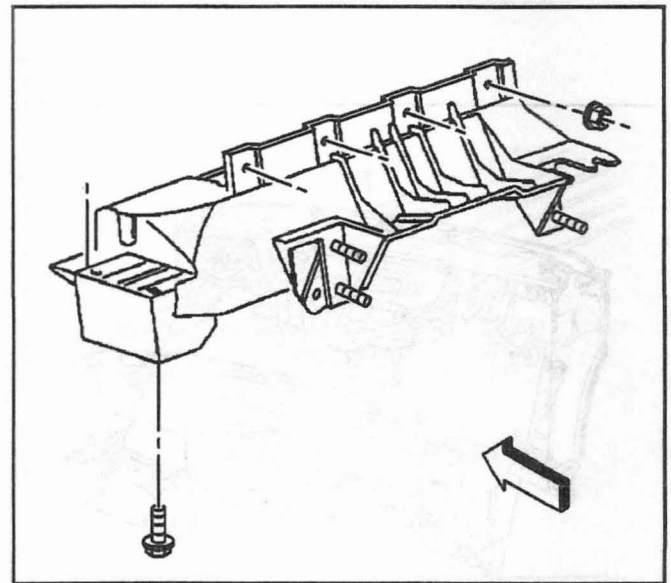

303371

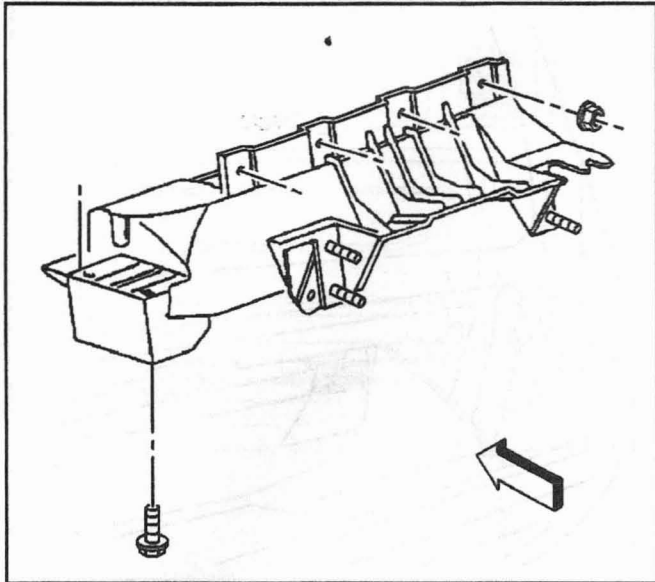

303371

### Installation Procedure

1. Install the brake pedal to the steering column support. Refer to *Brake Pedal Replacement in Hydraulic Brakes*.

**Notice:** Refer to *Fastener Notice* in Cautions and Notices.

2. Install the steering column support bracket fasteners.

#### Tighten

- Tighten the nuts to 25 N·m (18 lb ft).
- Tighten the bolts to 25 N·m (18 lb ft).

3. Install the brake switch. Refer to *Stoplamp Switch Replacement in Hydraulic Brakes*.
4. Install the brake booster pushrod to the brake pedal. Refer to *Vacuum Brake Booster Replacement in Hydraulic Brakes*.
5. Install the clutch master cylinder pushrod to the clutch pedal, if equipped. Refer to *Clutch Pedal Replacement in Clutch*.
6. Install the instrument panel. Refer to *IP Carrier Replacement*.

### IP Carrier Replacement

#### Removal Procedure

1. On vehicles equipped with a manual transmission, remove the shift lever.
2. On vehicles equipped with an automatic transmission, perform the following steps:
  - 2.1. Apply the park brake.
  - 2.2. Insert the ignition key and turn the ignition switch to the RUN position.
  - 2.3. Depress the brake pedal and shift the transmission to the 1 position.
  - 2.4. Turn the ignition switch to the OFF position.

**Caution:** Refer to *Battery Disconnect Caution in Cautions and Notices*.

3. Disconnect the battery negative cable.
4. Remove the left sound insulator. Refer to *Closeout/Insulator Panel Replacement - Left*.
5. Remove the right instrument panel sound insulator. Refer to *Closeout/Insulator Panel Replacement - Right*.
6. If the vehicle is equipped with a multiple CD changer located in the center console, remove the center console. Refer to *Console Replacement - Front Floor (Full Length (Envoy))*.
7. Remove the center sound insulator. Refer to *Closeout/Insulator Panel Replacement - Center*.
8. Remove the lower left instrument panel mounting bolt.
9. Remove and retain the instrument panel storage compartment. Refer to *Door Replacement - IP Storage Compartment Door*.
10. Remove the lower right instrument panel mounting bolt.

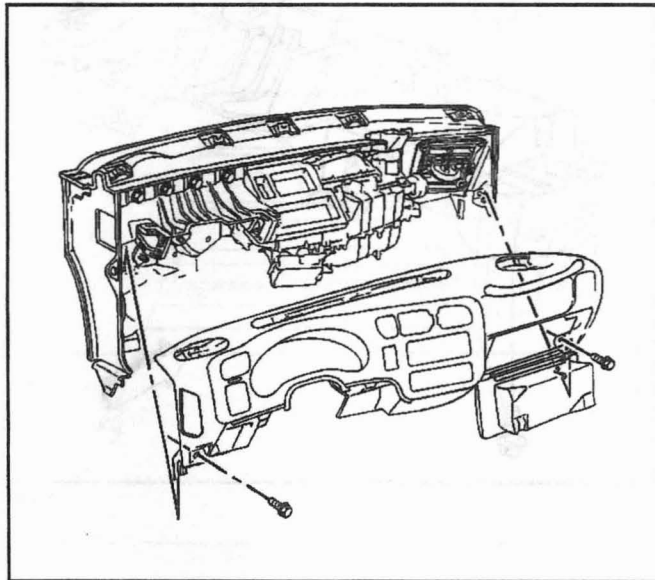

392686

11. Remove and retain the left and right speakers and the speaker grilles. Refer to *Speaker Replacement - Front* in Entertainment.
12. Use a flat-bladed tool in order to remove the windshield defroster grille. Retain the grille and the sunload sensor (if equipped) for use on the next IP carrier.

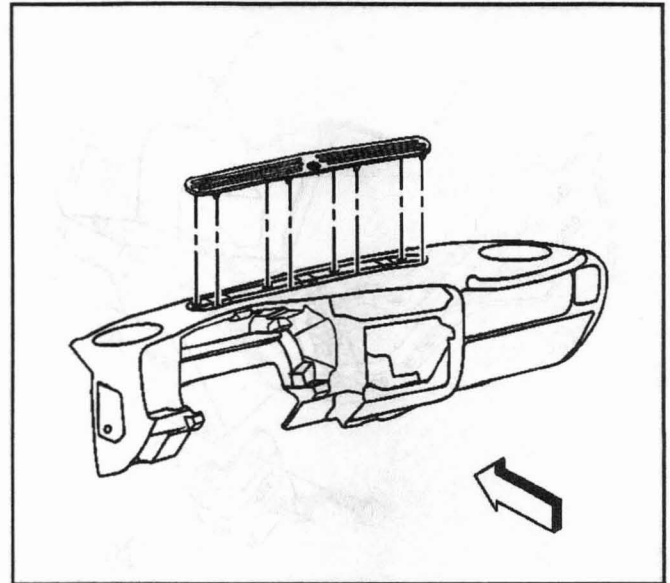

392691

13. If the vehicle is equipped with a sunload sensor, twist the sensor 1/4 turn counterclockwise in order to disengage the sensor.
14. Disconnect the brown electrical connection from the body control module (BCM).
15. Disconnect the purple electrical connection from the body control module (BCM).
16. Remove the knee bolster. Refer to *Knee Bolster Replacement*.
17. Remove and retain the instrument panel cluster. Refer to *IP Cluster Replacement*.
18. Remove and retain the radio. Refer to *Radio Replacement* in Entertainment.
19. Remove and retain the HVAC control assembly. Refer to the appropriate procedure:
  - *Control Assembly Replacement* in Heating and Ventilation (Non-A/C)
  - *Control Assembly Replacement* in HVAC Systems with A/C - Manual

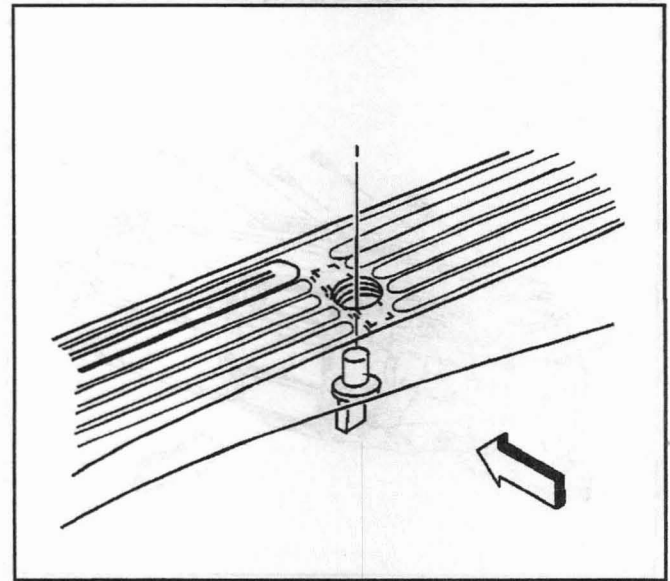

392690

**Caution:** Refer to *SIR Handling Caution in Cautions and Notices*.

20. Disable the passenger side SIR system. Refer to *Disabling the SIR System* in SIR.

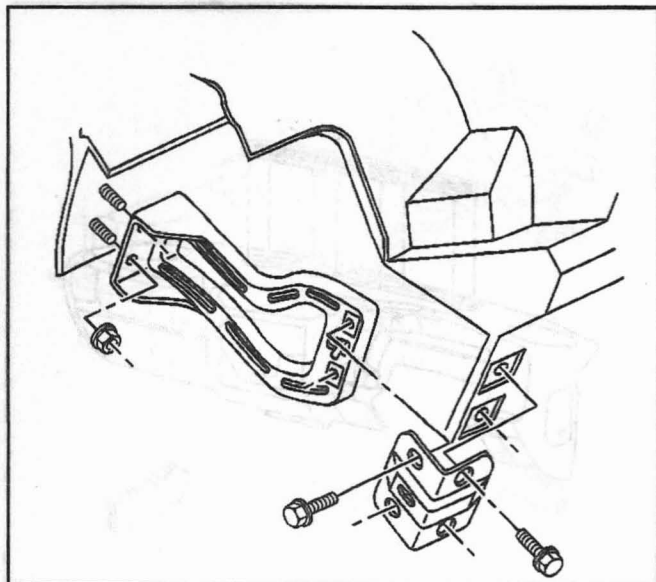

392681

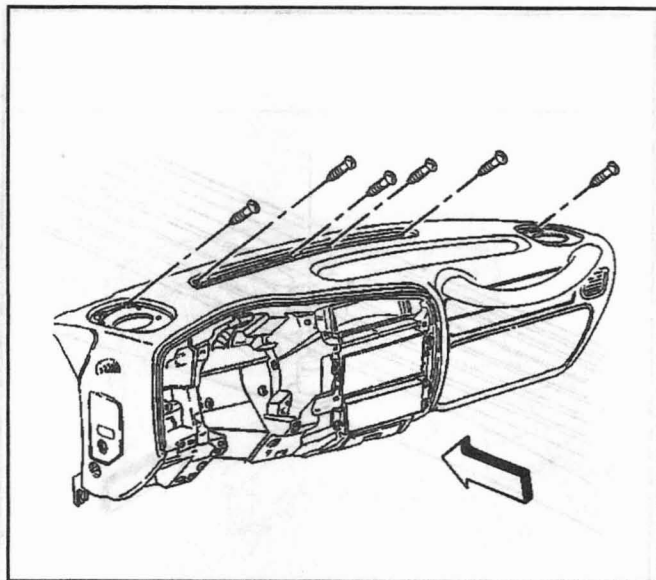

3C3370

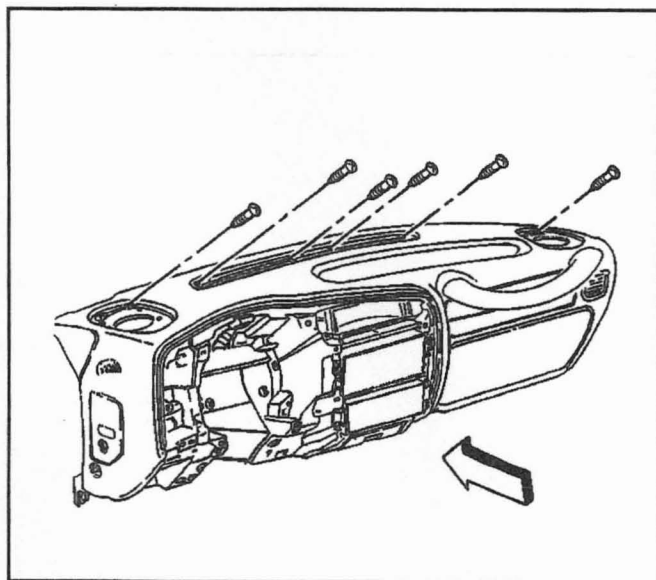

303370

21. Remove the left and right instrument panel driver knee bolster brackets.
22. Lower the steering column for clearance. Refer to the appropriate procedure:
  - *Steering Column Replacement in Steering Wheel and Column – Standard*
  - *Steering Column Replacement in Steering Wheel and Column – Tilt*

**Important:** Label all of the connections in order to avoid improper installation.

23. Remove the top instrument panel screws.
24. Roll the instrument panel down.
25. Disconnect the electrical connections, as needed.
26. Remove the fastener that retains the radio antenna cable to the instrument panel.
27. Remove the instrument panel from the vehicle.
28. If replacing the instrument panel carrier, retain parts for assembly of the new instrument panel carrier.

### Installation Procedure

1. Install retained parts from the original instrument panel.  
Install the instrument panel to the vehicle.

**Notice:** Refer to *Fastener Notice* in Cautions and Notices.

2. Install the fastener that retains the radio antenna cable to the instrument panel.

#### Tighten

Tighten the fastener to 1.9 N·m (17 lb in).

3. Connect the electrical connectors, as needed.
4. Roll the instrument panel up.
5. Install the top instrument panel screws.

#### Tighten

Tighten the screws to 1.9 N·m (17 lb in).

6. Raise the steering column into position. Refer to the appropriate procedure:
  - *Steering Column Replacement* in Steering Wheel and Column - Standard
  - *Steering Column Replacement* in Steering Wheel and Column - Tilt
7. Install the left and right instrument panel driver knee bolster brackets.

**Tighten**

Tighten the screws/bolts to 6.3 N·m (56 lb in).

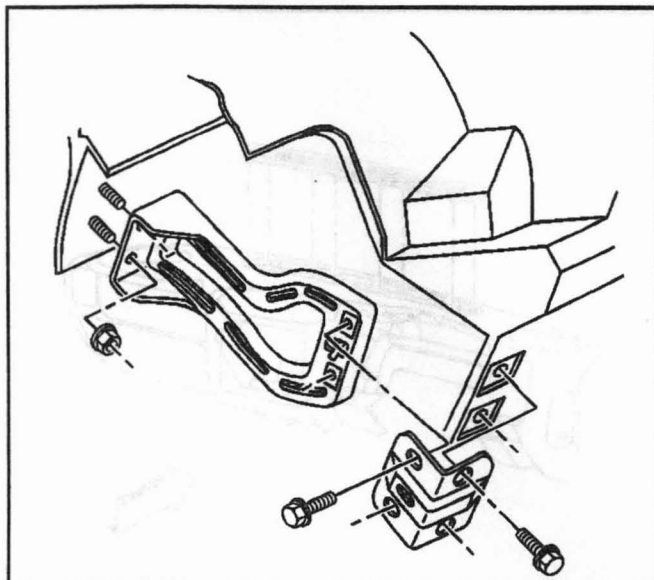

392681

8. Enable the passenger side SIR system. Refer to *Enabling the SIR System* in SIR.
9. Install the HVAC control assembly to the instrument panel. Refer to the appropriate procedure:
  - *Control Assembly Replacement* in Heating and Ventilation (Non-A/C)
  - *Control Assembly Replacement* in HVAC Systems with A/C - Manual
10. Install the radio. Refer to *Radio Replacement* in Entertainment.
11. Install the instrument cluster. Refer to *IP Cluster Replacement*.
12. Install the knee bolster. Refer to *Knee Bolster Replacement*.
13. Connect the purple electrical connection to the body control module (BCM).
14. Connect the brown electrical connection to the body control module (BCM).
15. If the vehicle is equipped with a sunload sensor, install the sensor to the defroster grille by twisting the sensor ¼ turn clockwise.

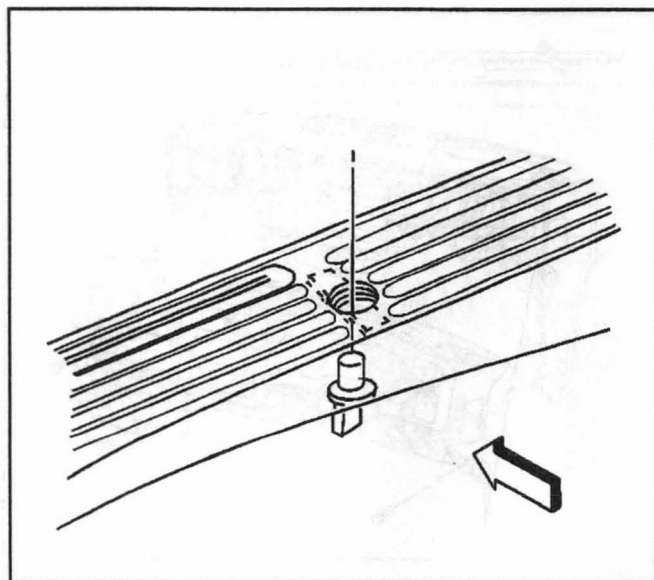

392690

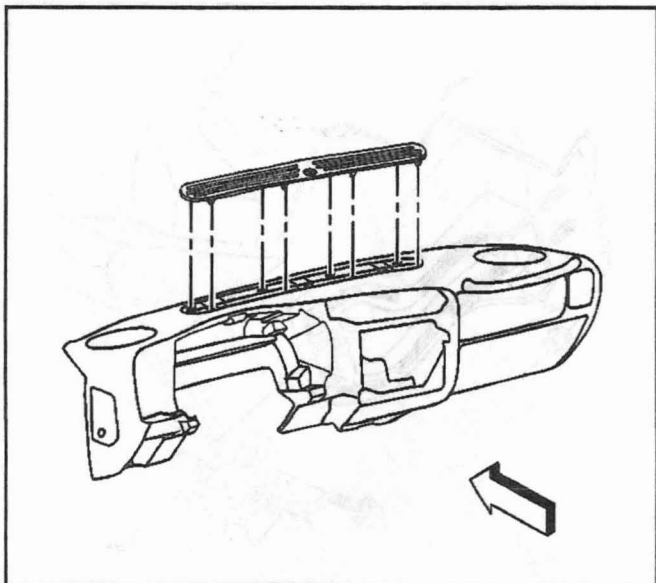

392691

16. Install the windshield defroster grille by carefully pressing the grille into place.
17. Install the left and right speakers and the speaker grilles. Refer to *Speaker Replacement - Front* in Entertainment.

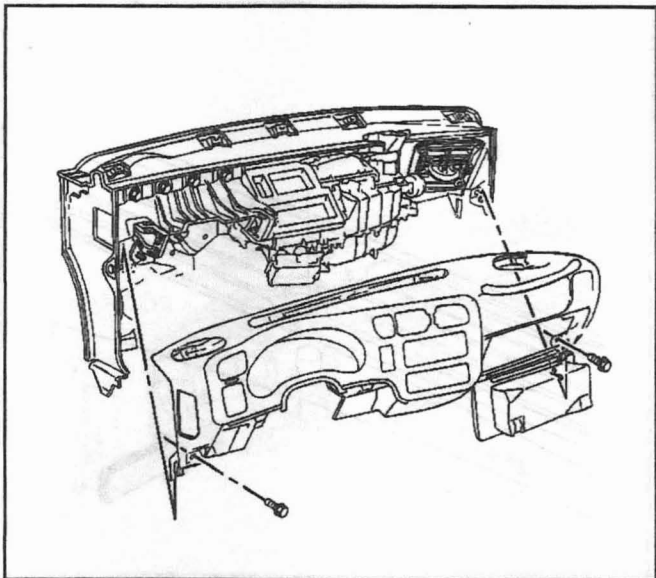

392686

18. Install the lower right instrument panel mounting bolt.  
**Tighten**  
Tighten the bolt to 11.5 N·m (102 lb in).
19. Install the instrument panel storage compartment. Refer to *Door Replacement - IP Storage Compartment Door*.
20. Install the lower left instrument panel bolt.  
**Tighten**  
Tighten the bolt to 11.5 N·m (102 lb in).
21. Install the center sound insulator. Refer to *Closeout/Insulator Panel Replacement - Center*.
22. Install the right sound insulator. Refer to *Closeout/Insulator Panel Replacement - Right*.
23. Install the center console to the vehicle, if removed. Refer to *Console Replacement - Front Floor (Full Length (Envoy))*.
24. Install the left sound insulator. Refer to *Closeout/Insulator Panel Replacement - Left*.
25. Connect the battery negative cable.
26. On vehicles equipped with an automatic transmission, perform the following steps:
  - 26.1. Turn the ignition switch to the RUN position.
  - 26.2. Depress the brake pedal and shift the transmission to the PARK position.
  - 26.3. Release the park brake.
27. On vehicles equipped with a manual transmission, install the shift lever.

## IP Cluster Replacement

### Removal Procedure

**Notice:** When replacing a speedometer or odometer assembly, federal law requires that the odometer reading of the replacement unit be set to register the same mileage as the prior odometer. If the same mileage cannot be set, the law requires that the replacement odometer be set at zero and a label be installed on the driver's door frame to show the previous reading and the date of replacement.

**Important:** All warning lamps use a Light Emitting Diode (LED). The LED is not serviceable. If a warning lamp's LED stops functioning, exchange the instrument cluster. A serviceable incandescent light is used in the following components:

- The high-beam indicator
- The turn signal indicators
- The dash lights

**Caution: Refer to Battery Disconnect Caution in Cautions and Notices.**

1. Disconnect the battery negative cable.
2. Remove the instrument panel accessory trim plate. Refer to *Trim Plate Replacement - IP Accessory*.
3. Remove the four screws that retain the cluster to the instrument panel.
4. Disconnect the electrical connectors as needed.
5. Remove the cluster from the instrument panel.

### Installation Procedure

1. Install the cluster to the instrument panel.  
Firmly seat the cluster onto the instrument panel.
2. Connect the electrical connections as needed.

**Notice:** Refer to *Fastener Notice* in Cautions and Notices.

3. Install the instrument cluster screws.

#### Tighten

Tighten the screws to 1.9 N·m (17 lb in).

4. Install the instrument panel accessory trim plate. Refer to *Trim Plate Replacement - IP Accessory*.
5. Connect the battery negative cable.

For more information on the instrument panel cluster gauges, refer to *Instrument Cluster Description*.

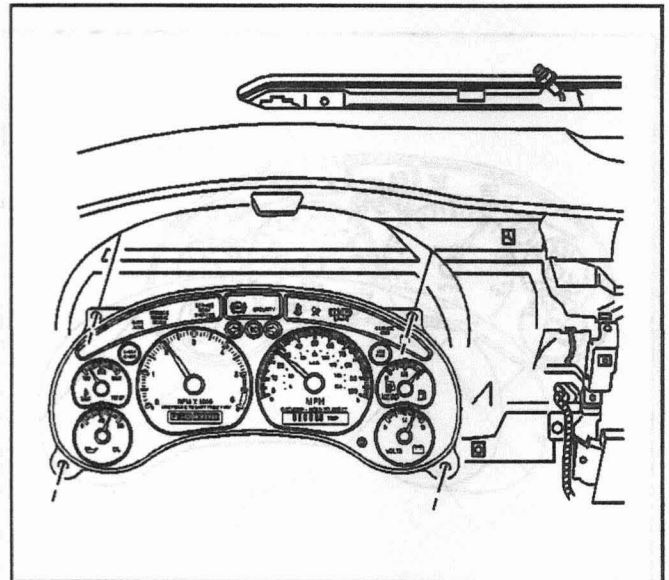

298989

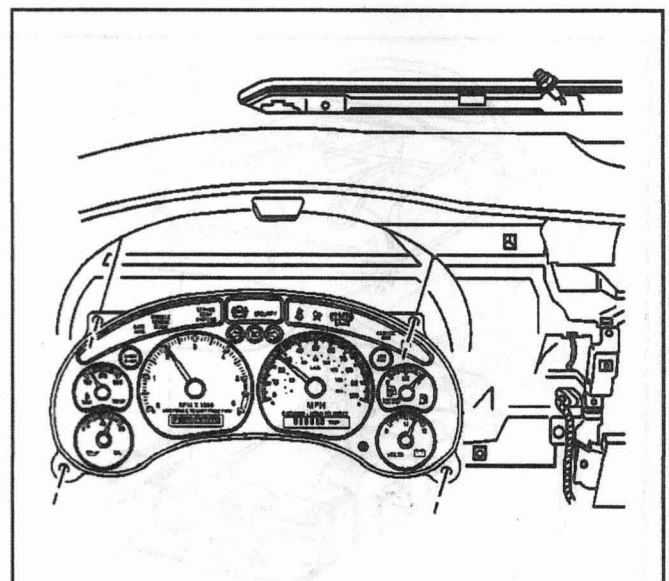

298989

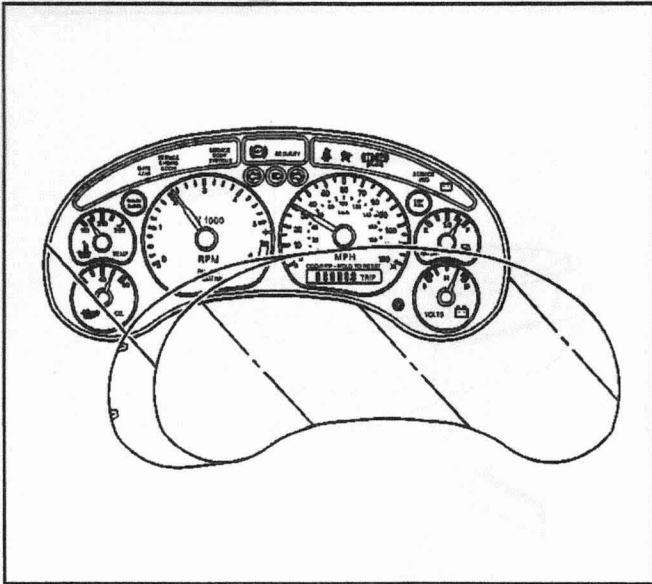

298992

## IP Cluster Lens Replacement

### Removal Procedure

1. Remove the instrument panel cluster. Refer to *IP Cluster Replacement*.
2. Gently pry the lens retaining tabs away from the cluster housing.
3. Remove the lens from the cluster housing.

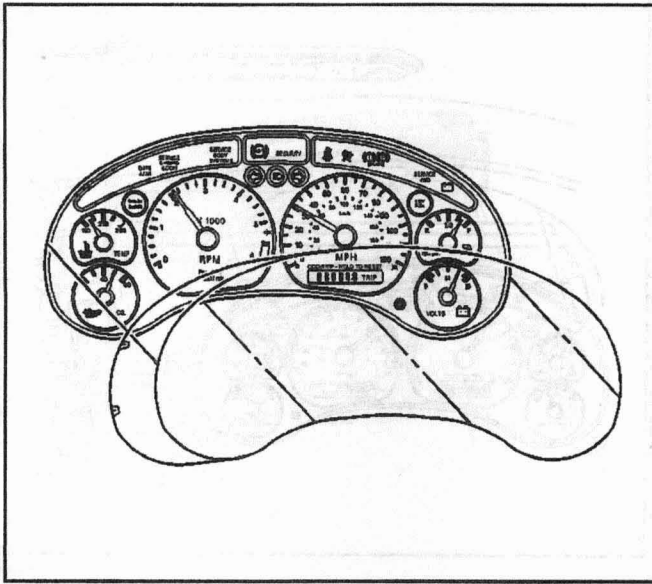

298992

### Installation Procedure

1. Install the lens to the cluster housing by snapping it into place.
2. Install the instrument panel cluster. Refer to *IP Cluster Replacement*.

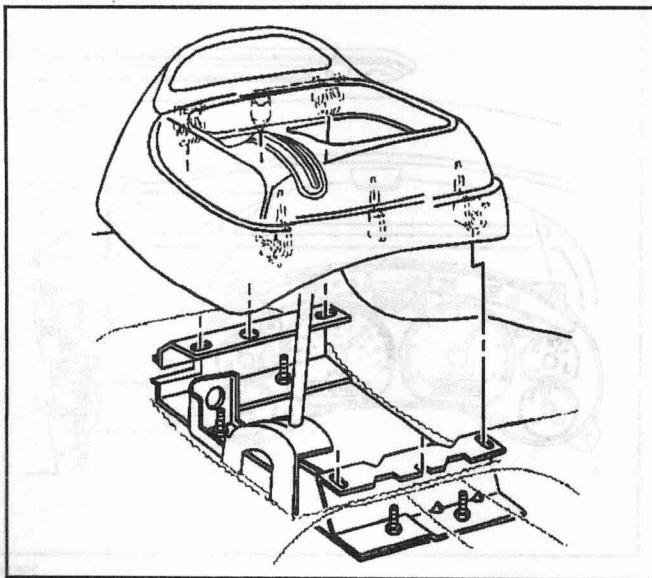

303463

## Console Replacement - Front Floor (Non-Full Length)

### Removal Procedure

1. Remove the shift control lever (manual transmission only). Refer to *Shift Lever* or *Shift Lever* in Manual Transmission.
2. Remove the console from the floor.  
Pull up on the console in order to release the retainer clips.

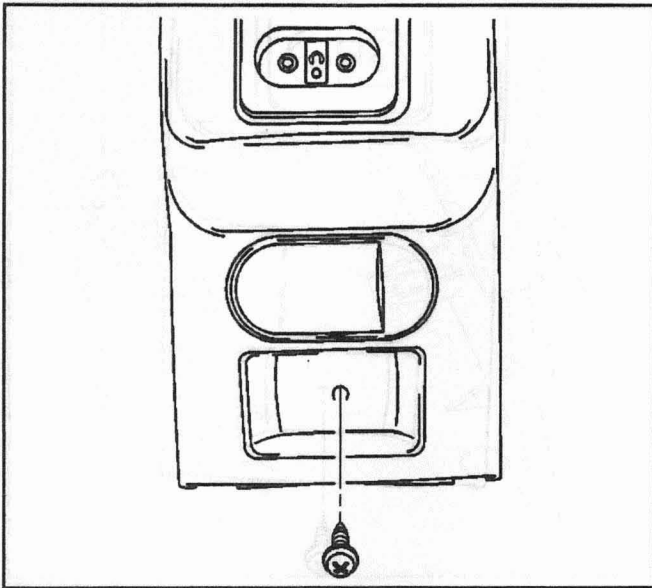

401754

**Notice:** Refer to *Fastener Notice* in *Cautions and Notices*.

4. Install the rear console trim panel retaining screw.  
**Tighten**  
Tighten the screw to 1.9 N·m (17 lb in).
5. Install the negative battery cable.

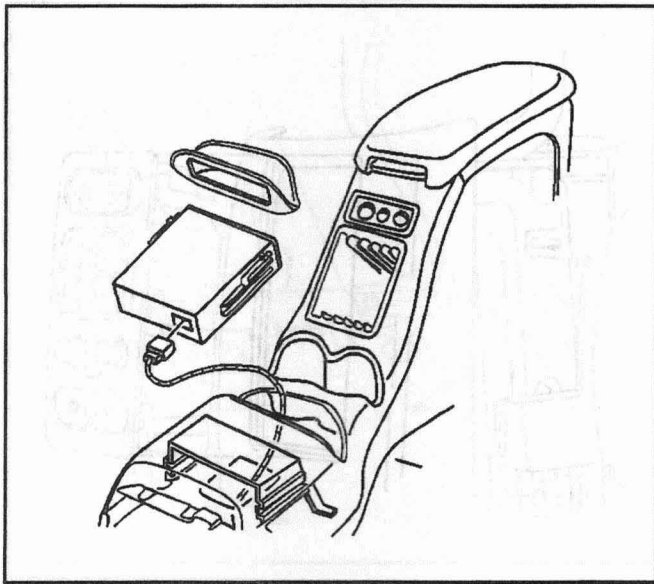

419695

### Remote Cassette Player Replacement

#### Removal Procedure

**Caution:** Refer to *Battery Disconnect Caution* in *Cautions and Notices*.

1. Remove the negative battery cable.
2. Remove the remote cassette player tray by prying gently with a flat-bladed tool.
3. Remove the remote cassette player by gently pulling the unit outward from the console.
4. Remove the electrical connector.

*Push down vertically on retaining tabs on either side of player*

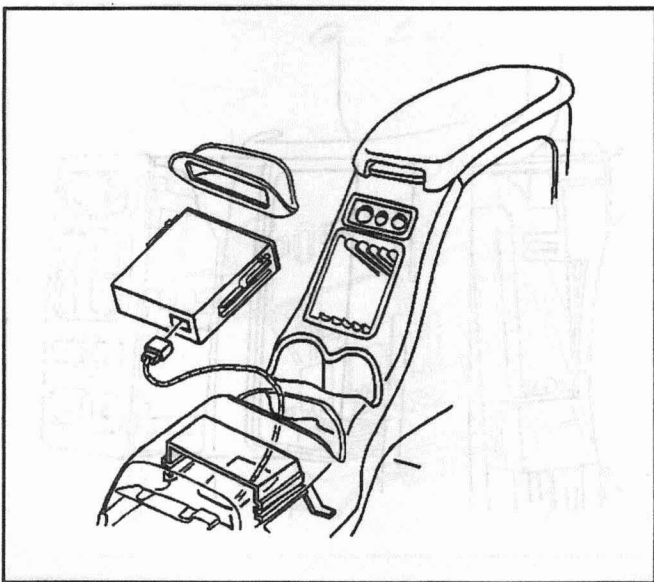

419695

#### Installation Procedure

1. Install the electrical connector.
2. Install the remote cassette player to the console, by sliding the unit into place between the retaining tabs.
3. Install the remote cassette player tray, ensuring the unit locks into place.
4. Install the negative battery cable.

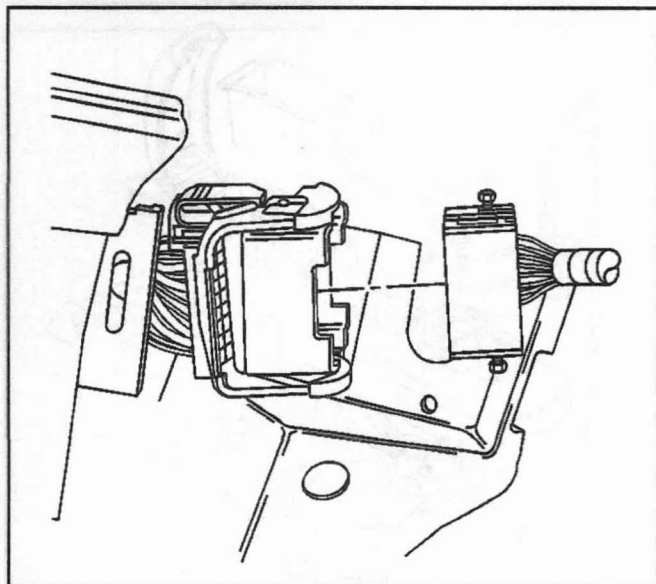

384281

### Console Replacement - Front Floor (Full Length (Envoy))

#### Removal Procedure

- ✓ 8-340 or cassette player
1. Remove the front ashtray from console by gently prying out the ashtray with a flat-bladed tool.
  2. Carefully lift up on the wood shifter assembly close-out in order to remove the assembly from the console. The closeout panel will need to be rotated to fit over the shift handle.
  3. Remove the passenger side toe-panel by gently prying out the panel using a flat-bladed tool.
  4. Disconnect the instrument panel to console wiring harness connection.

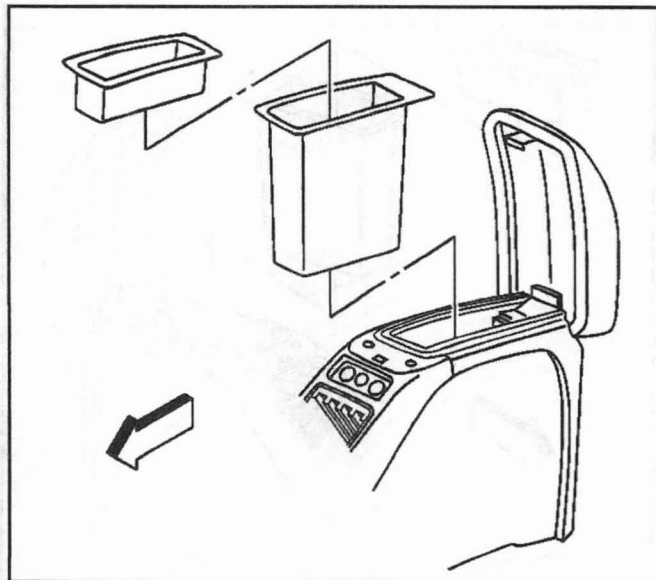

392688

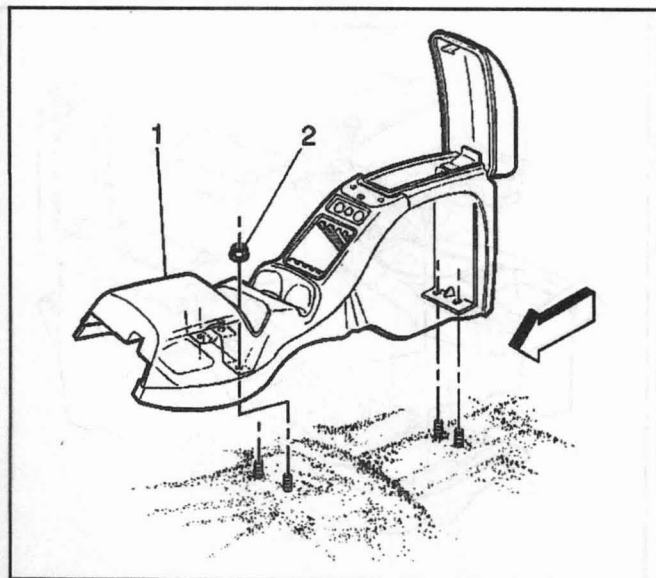

417790

5. Open the armrest in order to expose and remove the convenience tray from storage compartment.

6. Remove the fasteners (2) that retain the console (1) to the shifter assembly and the vehicle floor.
7. Remove the console from the vehicle by lifting the console over the floor studs.
8. If replacing the center console, remove the compact disc player from the console. Refer to *Remote CD Changer Replacement* in Entertainment.
9. If replacing the center console, remove the amplifier from the console. Refer to *Amplifier Replacement* in Entertainment.
10. If replacing the center console, remove the rear seat audio control from the console. Refer to *Rear Seat Audio Control Replacement* in Entertainment.
11. If replacing the center console, remove and retain the console wiring harness for use on the new console.

**Installation Procedure**

1. Install the console wiring harness to the console.
2. Install the rear seat audio control to the console. Refer to *Rear Seat Audio Control Replacement* in Entertainment.
3. Install the amplifier from the console. Refer to *Amplifier Replacement* in Entertainment.
4. Install the compact disc player from the console. Refer to *Remote CD Changer Replacement* in Entertainment.
5. Install the console to the vehicle by lifting the console (1) over and onto the floor studs.

**Important:** Do not pinch the instrument panel to console wiring harness during this process.

**Notice:** Refer to *Fastener Notice* in Cautions and Notices.

6. Install the fasteners (2) that retain the console to the vehicle.

**Tighten**

Tighten the console to the vehicle retainers to 10 N·m (88 lb in).

7. Install the convenience tray to the armrest storage compartment.

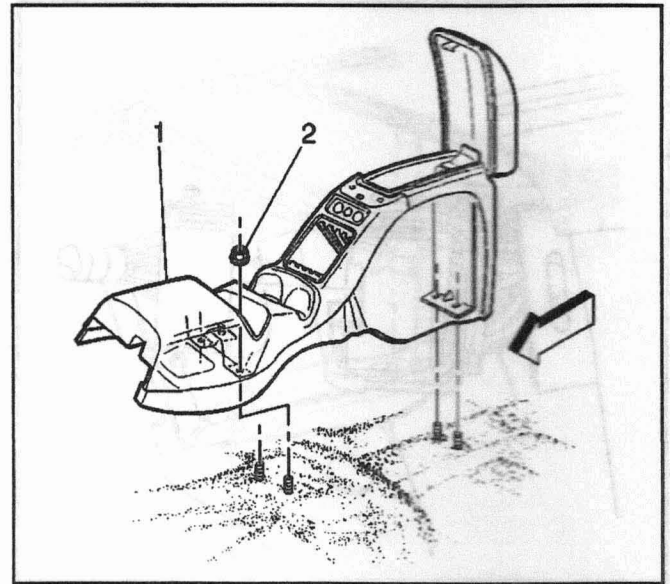

417790

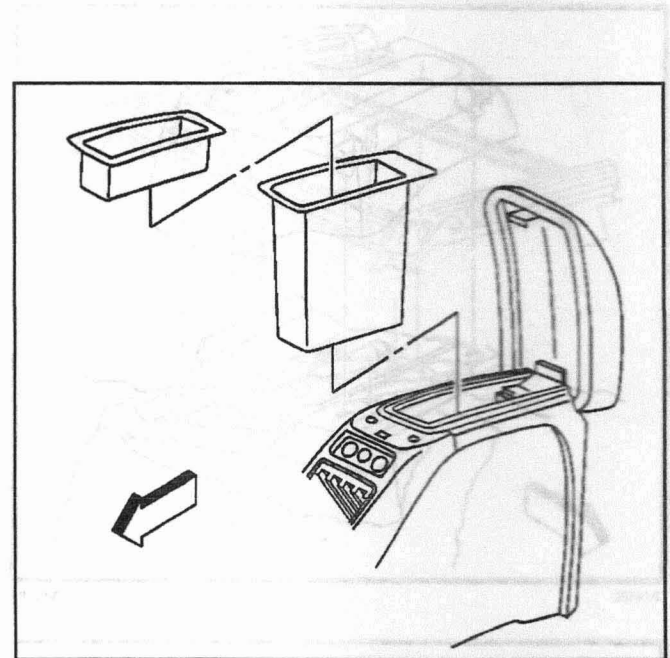

392688