

14. Remove the wheel hub and bearing seal from the wheel hub and bearing assembly.

Installation Procedure

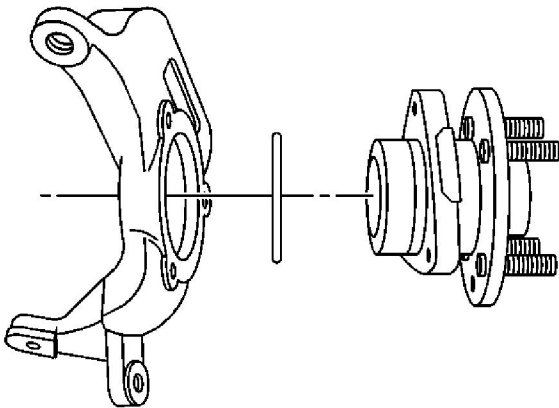

1. Install the wheel hub and bearing seal to the wheel hub and bearing assembly.
2. Install the splash shield to the steering knuckle. Align the shield to the steering knuckle.

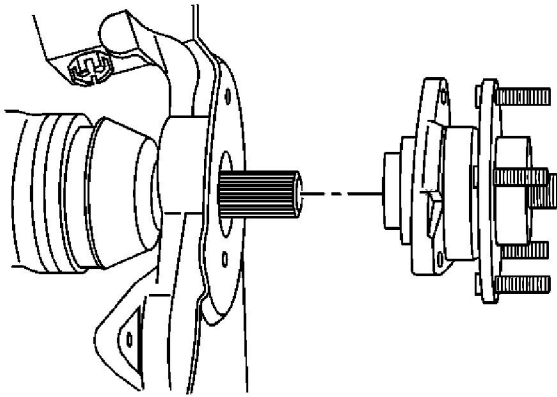

3. Install the wheel hub and bearing assembly to the steering knuckle. Align the threaded holes.

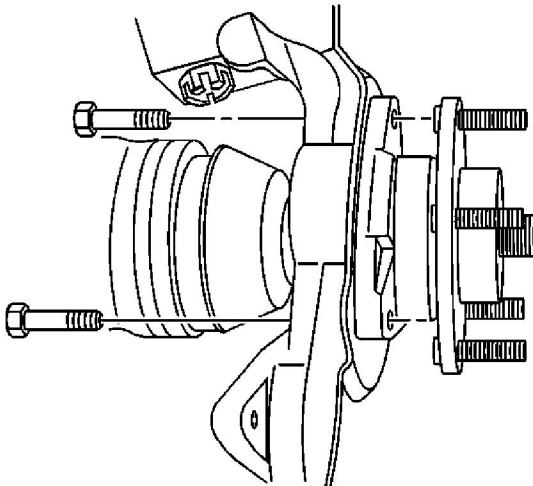

Notice

Use the correct fastener in the correct location. Replacement fasteners must be the correct part number for that application. Fasteners requiring replacement or fasteners requiring the use of thread locking compound or sealant are identified in the service procedure. Do not use paints, lubricants, or corrosion inhibitors on fasteners or fastener joint surfaces unless specified. These coatings affect fastener torque and joint clamping force and may damage the fastener. Use the correct tightening sequence and specifications when installing fasteners in order to avoid damage to parts and systems.

4. Install the wheel hub and bearing assembly to the steering knuckle mounting bolts. **Tighten**

Tighten the wheel hub and bearing assembly to the steering knuckle mounting bolts to 105 N·m (77 lb ft).

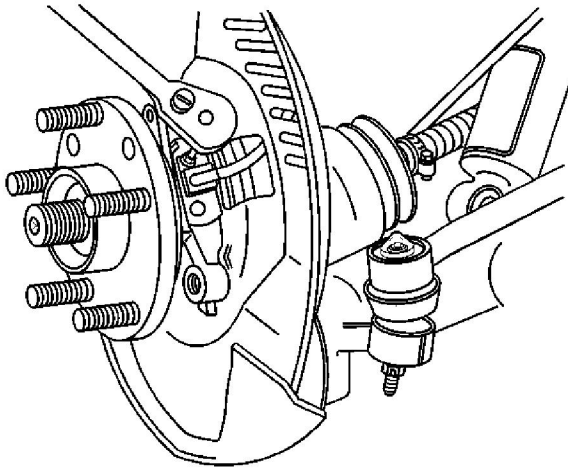

5. Install the wheel speed sensor to the wheel hub and bearing assembly.
6. Install the wheel speed sensor to the wheel hub and bearing assembly mounting bolt. **Tighten**

Tighten the wheel speed sensor to the wheel hub and bearing assembly mounting bolt to 18 N·m (13 lb ft).

7. Install the rotor. Refer to [Brake Rotor Replacement - Front](#) in Disc Brakes.

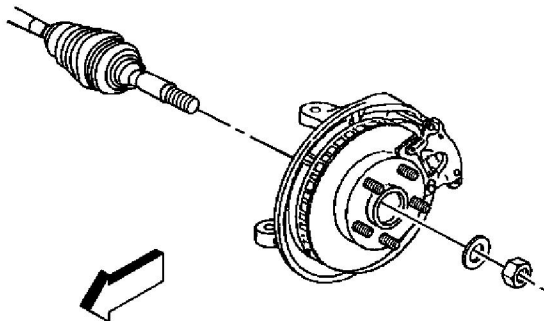



8. Apply the brake pedal.
9. Install the drive axle washer.
10. Install the drive axle nut. **Tighten**

Tighten the drive axle nut to 140 N·m (103 lb ft).

11. Install the tire and the wheel. Refer to [Tire and Wheel Removal and Installation](#) in Tires and Wheels.
12. Load the torsion bar. Refer to [Torsion Bar and Support Assembly Replacement](#) .
13. Lower the vehicle.

<- Back

Forward ->

Document ID# 539230
2000 Chevrolet/Geo Blazer - 4WD

Print