

288800

6. Install the intermediate shaft shield to the power steering gear.

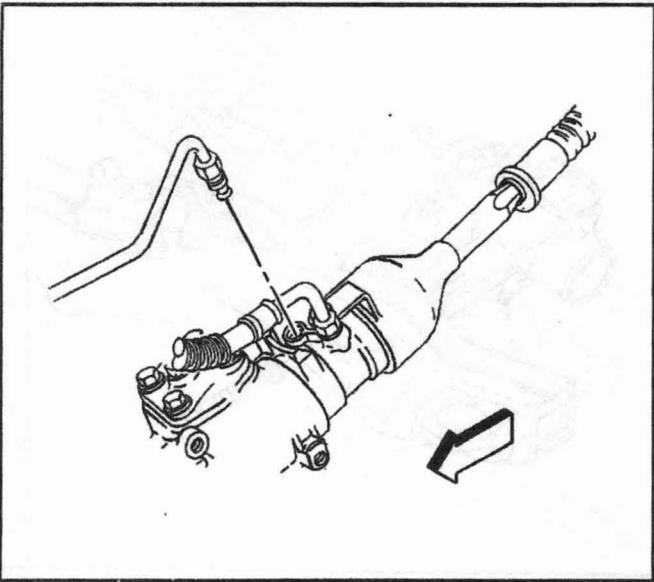

395770

7. Install the pressure and the return hoses to the power steering gear.

#### Tighten

- Tighten the pressure hose to 25 N·m (18 lb ft) for the vehicle equipped with the 2.2L engines.
  - Tighten the pressure hose to 30 N·m (22 lb ft) for the vehicle equipped with the 4.3L engines.
  - Tighten the return hose to 25 N·m (18 lb ft).
8. Install the air cleaner assembly.
9. Bleed the power steering system. Refer to *Bleeding Power Steering System*.

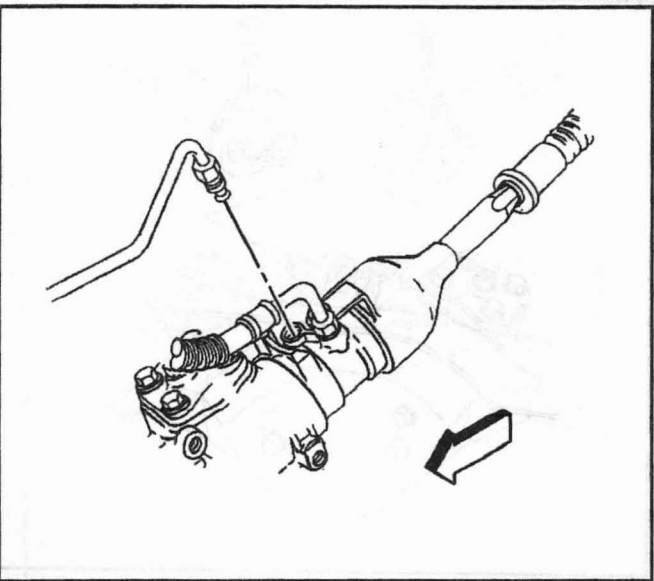

395770

## Power Steering Gear Replacement (4WD)

### Removal Procedure

#### Tools Required

J 24319-B Steering Linkage Puller

**Notice:** Do not rotate steering shaft after steering column has been removed. Damage to SIR components may occur.

1. Remove the air cleaner assembly.
2. Place a drain pan below the steering gear.
3. Remove the pressure and the return hoses from the power steering gear.

Cap or tape the ends of the hoses and the gear fittings in order to prevent dirt from entering the system.

4. Remove the intermediate shaft shield from the steering gear.

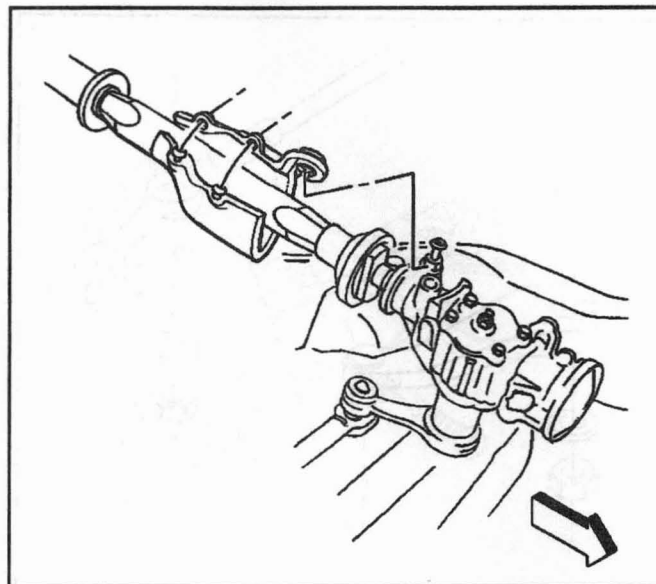

288800

5. Remove the lower intermediate shaft coupling bolt.
6. Draw alignment marks on the lower intermediate shaft coupling and the steering shaft.
7. Remove the lower intermediate shaft coupling from the steering shaft.
8. Raise the vehicle. Refer to *Lifting and Jacking the Vehicle* in General Information.
9. Remove the steering linkage shield. Refer to *Steering Linkage Shield Replacement* in Steering Linkage.

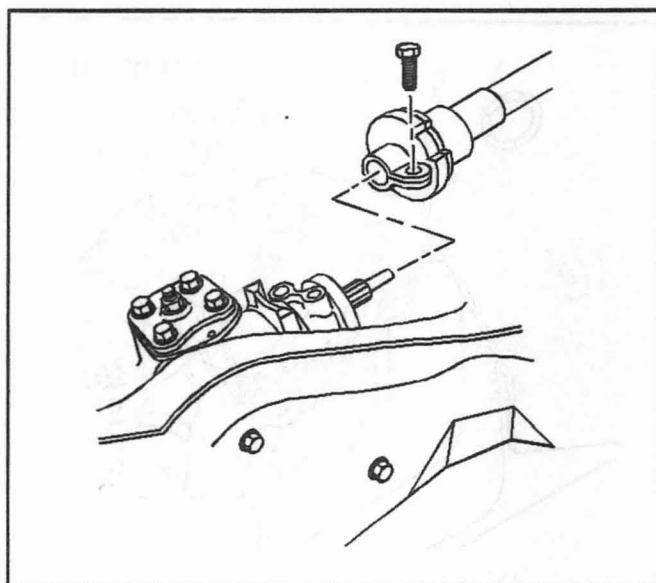

692

10. Remove differential carrier shield mounting bolts.
11. Remove the differential carrier shield.

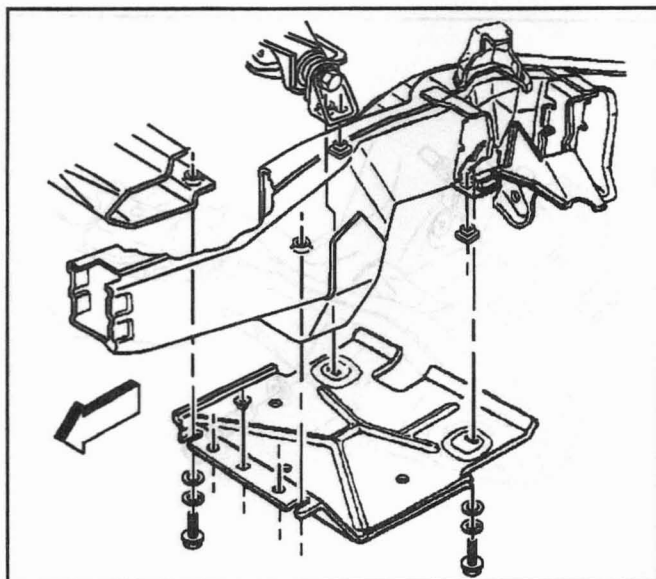

141840

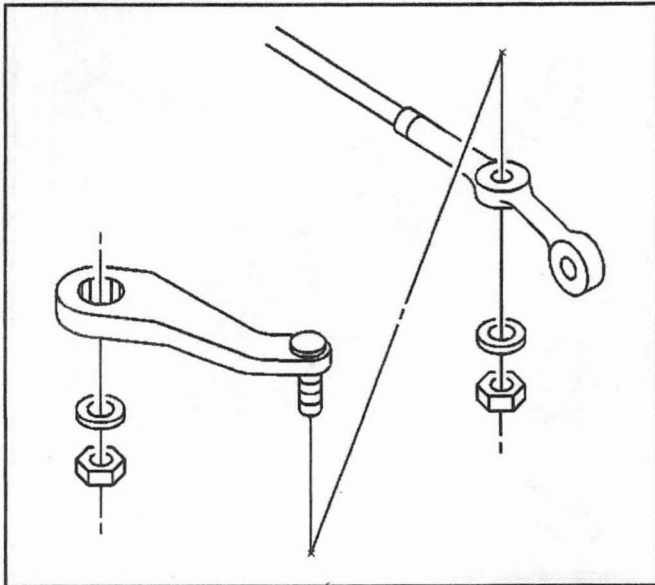

291254

- 12. Remove the pitman arm ball stud nut at the relay rod.

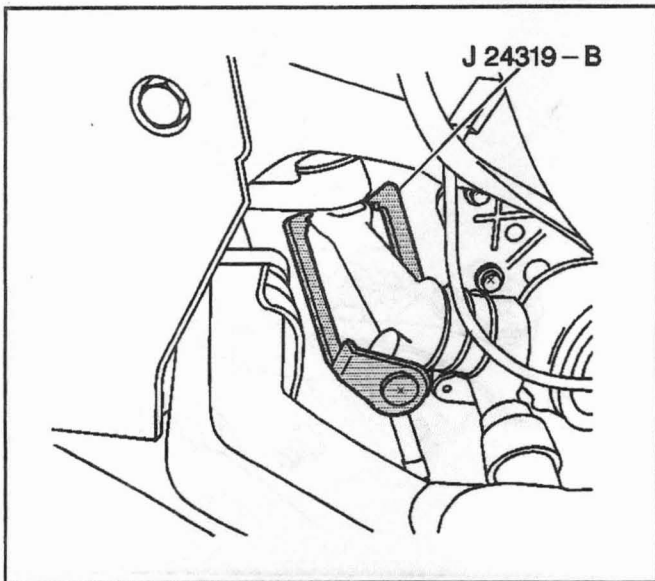

397366

- 13. Disconnect pitman arm from relay rod using J 24319-B.

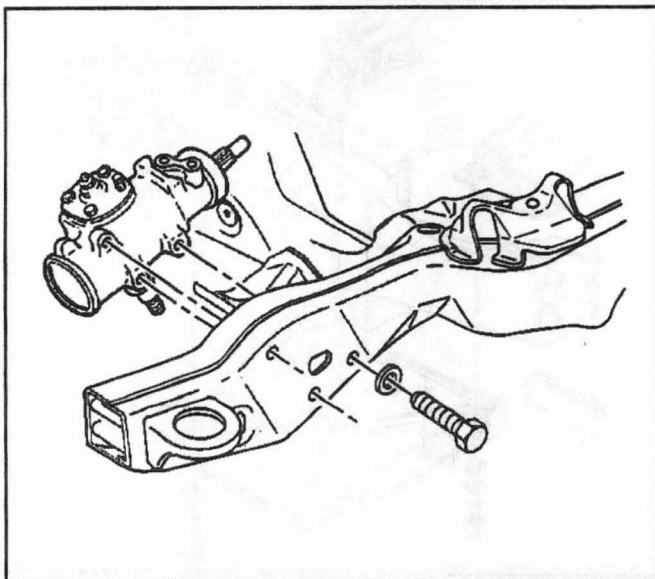

288824

- 14. Remove the steering gear mounting bolts and the washers from the frame.
- 15. Remove the steering gear.
- 16. Remove the pitman arm. Refer to *Pitman Arm Replacement (4WD)* in Steering Linkage.

Pa 2-110

**Installation Procedure****Tools Required**

- J 29193 Steering Linkage Installer (12 mm)
- J 29194 Steering Linkage Installer (14 mm)

1. Install the pitman arm. Refer to *Pitman Arm Replacement (4WD)* in Steering Linkage.
2. Install the steering gear.

**Notice:** Refer to *Fastener Notice* in Cautions and Notices.

3. Install the power steering gear to the frame washers and mounting bolts.

**Tighten**

Tighten the power steering gear to frame mounting bolts to 75 N·m (55 lb ft).

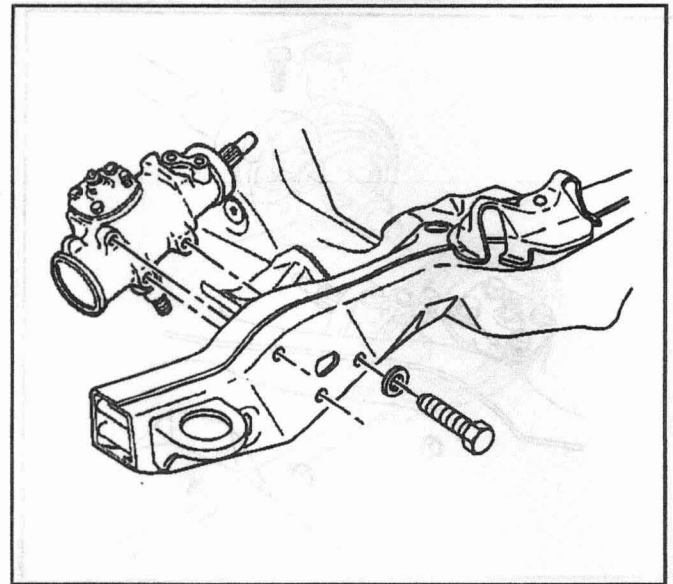

288824

4. Connect the relay rod to the pitman arm ball stud. Ensure the seal is on the stud.
5. Seat the taper using J 29193 or J 29194.

**Tighten**

Tighten J 29193 or J 29194 to 62 N·m (48 lb ft).

6. Remove J 29193 or J 29194 from the pitman arm ball stud.
7. Install the new nut to the pitman arm ball stud at the relay rod.

**Tighten**

Tighten the pitman arm ball stud nut at the relay rod to 83 N·m (61 lb ft).

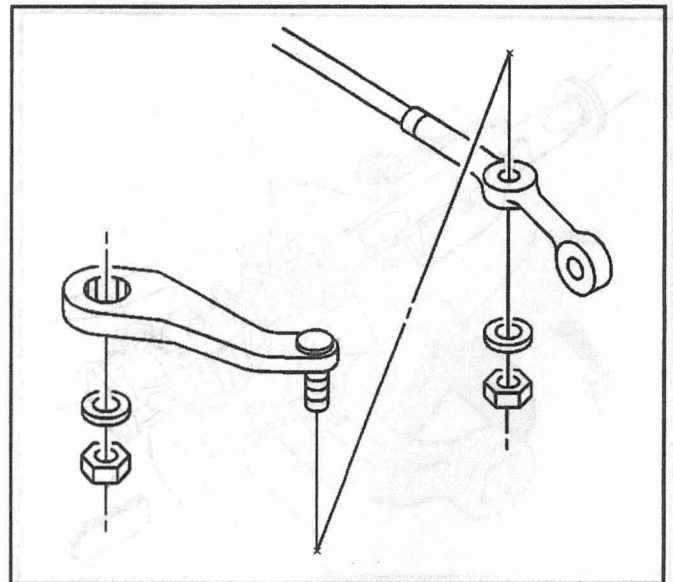

291254

8. Install differential carrier shield.
9. Install the differential carrier shield mounting bolts.
10. Install the steering linkage shield. Refer to *Steering Linkage Shield Replacement* in Steering Linkage.
11. Lower the vehicle.

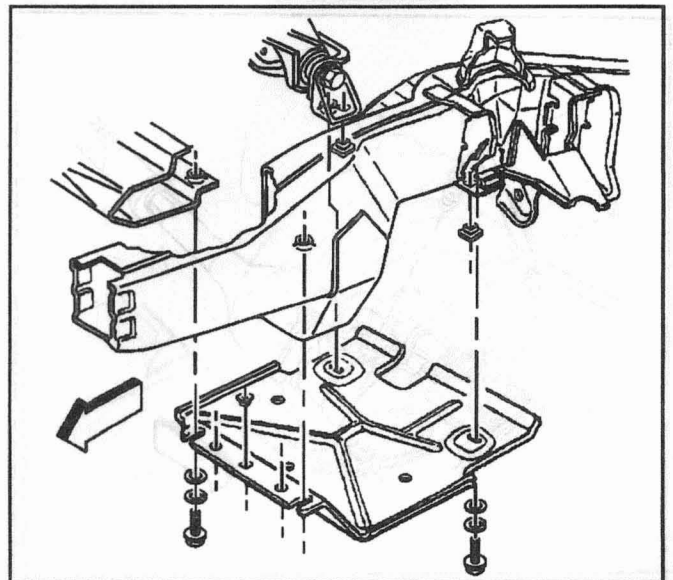

141840

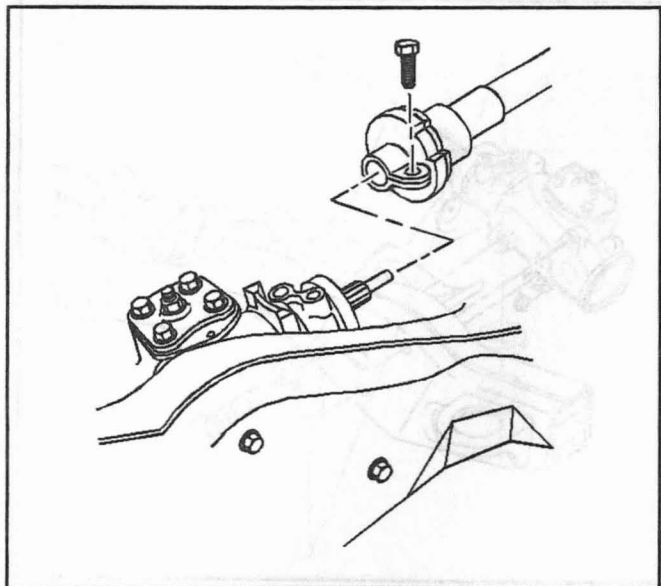

692

12. Install the lower intermediate shaft to the power steering gear.
13. Ensure that the alignment marks line up.
14. Install the lower intermediate shaft coupling bolt.

**Tighten**

Tighten the lower intermediate shaft coupling bolt to 35 N·m (26 lb ft).

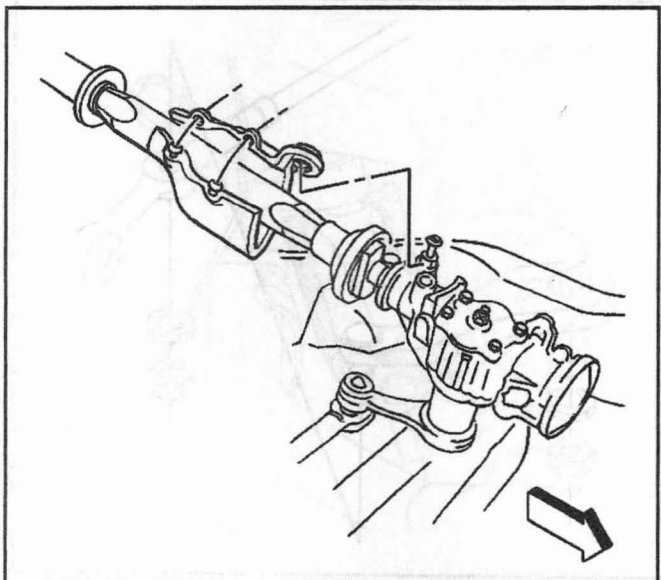

288800

15. Install the intermediate shaft shield to the power steering gear.

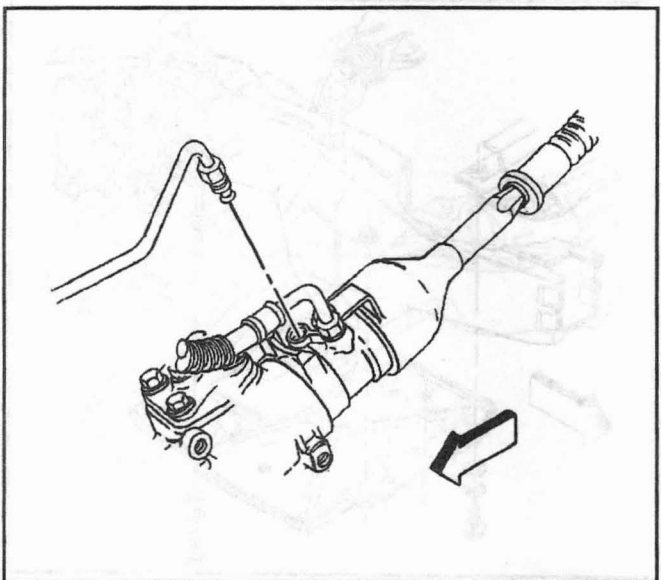

395770

16. Install the pressure and return hoses to the power steering gear.

**Tighten**

- Tighten the pressure hose to 30 N·m (22 lb ft).
- Tighten the return hose to 25 N·m (18 lb ft).

17. Install the air cleaner assembly.
18. Bleed the power steering system. Refer to *Bleeding Power Steering System*.