

< - Back

Forward ->

Document ID# 443619
1999 Chevrolet/Geo Blazer - 4WD

Print

Knock Sensor (KS) Replacement

[Removal Procedure](#)

Tools Required

[J 35748](#) Oil Pressure Sending Unit Socket

Caution

Before servicing any electrical component, the ignition key must be in the OFF or LOCK position and all electrical loads must be OFF, unless instructed otherwise in these procedures. If a tool or equipment could easily come in contact with a live exposed electrical terminal, also disconnect the negative battery cable. Failure to follow these precautions may cause personal injury and/or damage to the vehicle or its components.

1. Disconnect the negative battery cable.

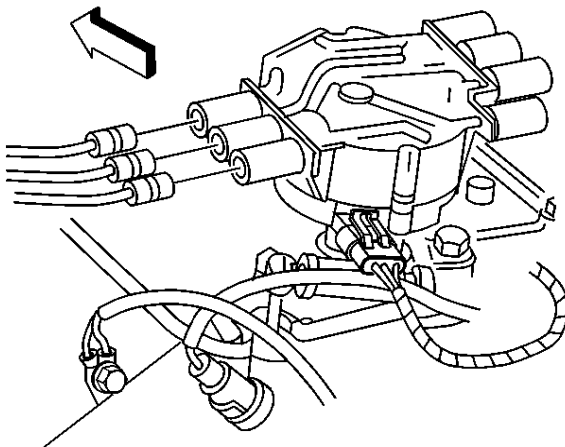

2. Disconnect the spark plug wires and ignition coil wire from the distributor.

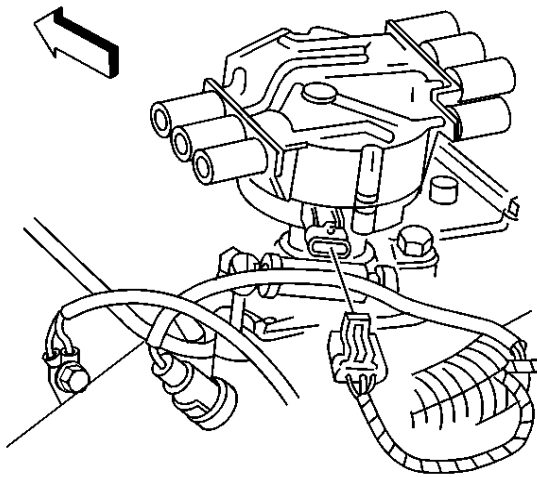

3. Disconnect the CMP sensor harness connector from the distributor.

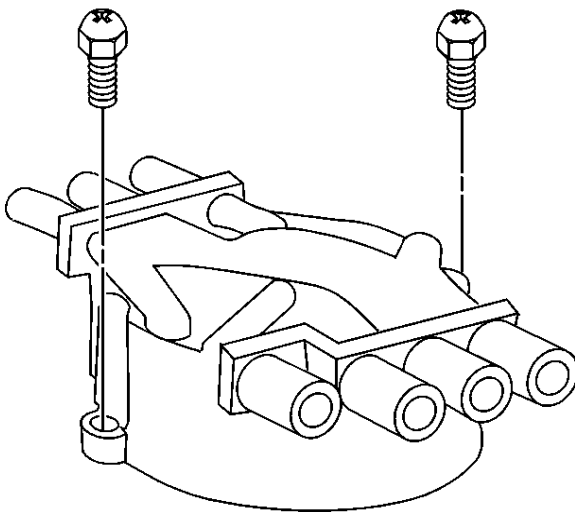

4. Remove the distributor cap screws.

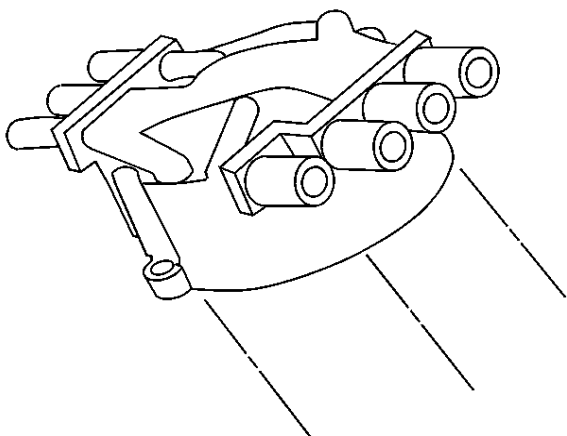

5. Remove the distributor cap.

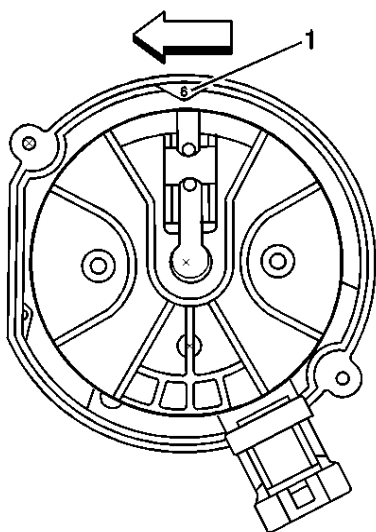

Important

A DTC P1345 will set if the rotor is not reinstalled in the exact position the rotor was in prior to removal.

6. Observe the alignment of the rotor in relation to the distributor base (1).

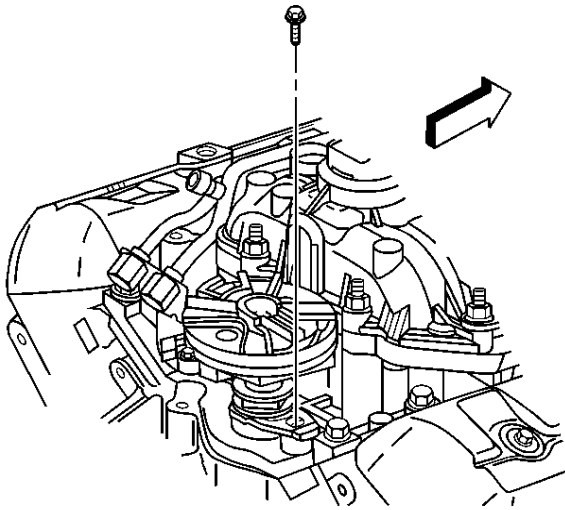

7. Remove the distributor mounting bolt.

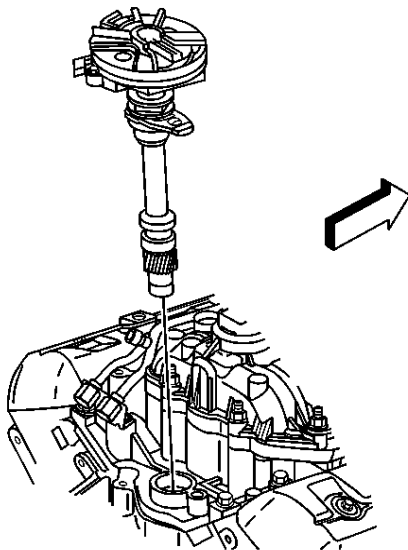

8. Remove the distributor assembly.
9. Discard the distributor gasket.

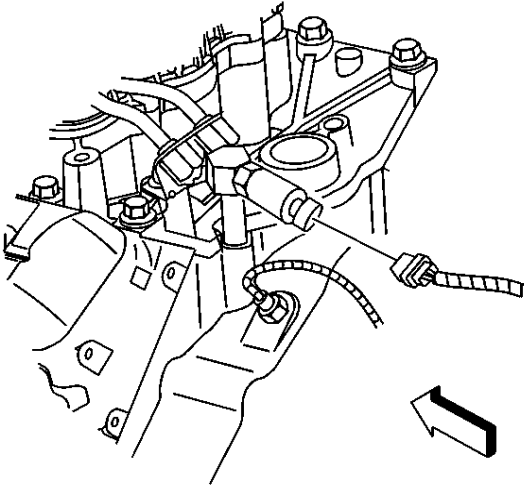

10. Disconnect the engine oil pressure sensor harness connector.

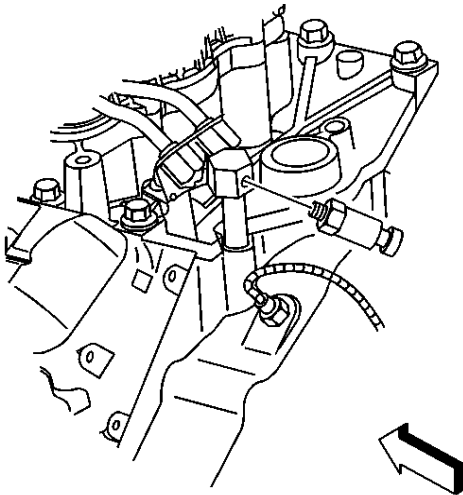

11. Remove the engine oil pressure sender with a [J 35748](#) Oil Pressure Sending Unit Socket.

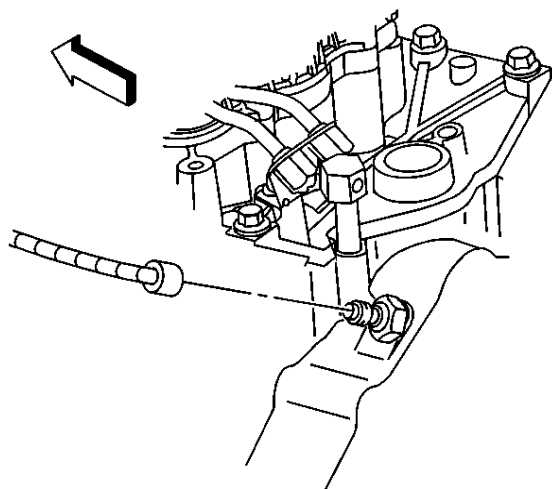

12. Remove the knock sensor harness connector.

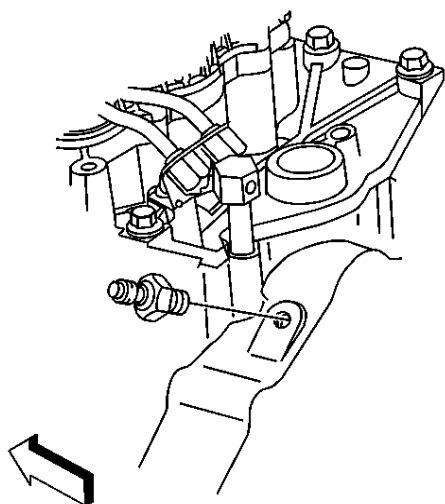

13. Remove the knock sensor.

[Installation Procedure](#)

Tools Required

[J 35748](#) Oil Pressure Sending Unit Socket

Important

Do not use the old screws for the distributor cap, CMP sensor, and rotor . Use replacement screws that have been coated with a thread locking compound.

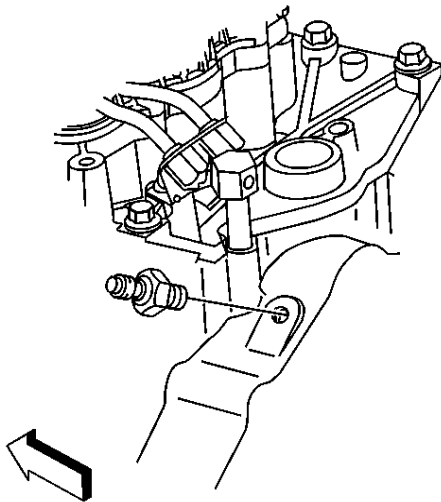

Notice

Replacement components must be the correct part number for the application. Components requiring the use of the thread locking compound, lubricants, corrosion inhibitors, or sealants are identified in the service procedure. Some replacement components may come with these coatings already applied. Do not use these coatings on components unless specified. These coatings can affect the final torque, which may affect the operation of the component. Use the correct torque specification when installing components in order to avoid damage.

1. Install the knock sensor.

Tighten

Tighten the sensor to 20 N·m (15 lb ft)

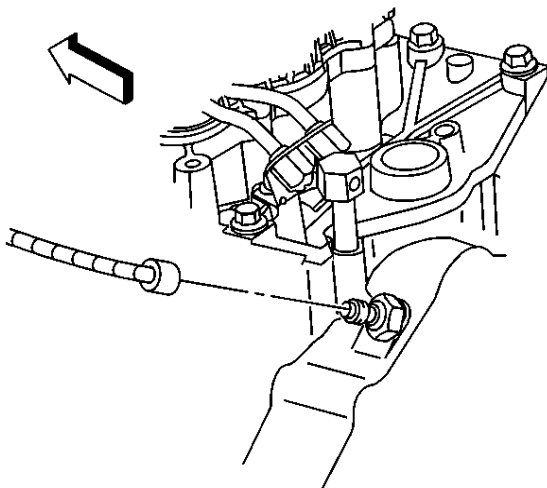



2. Connect the knock sensor harness connector.

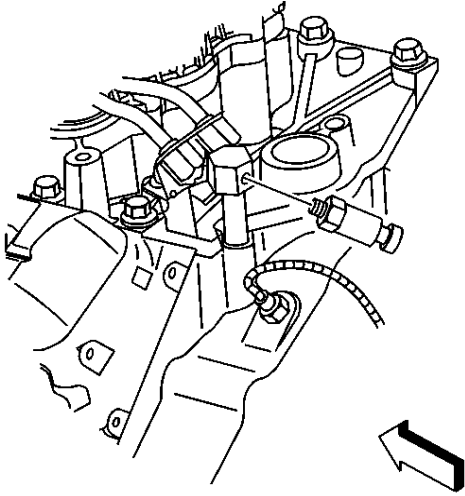

3. Install the engine oil pressure sender with a [J 35748](#) Oil Pressure Sending Unit Socket.

Tighten

Tighten the sender to 30 N·m (22 lb ft)

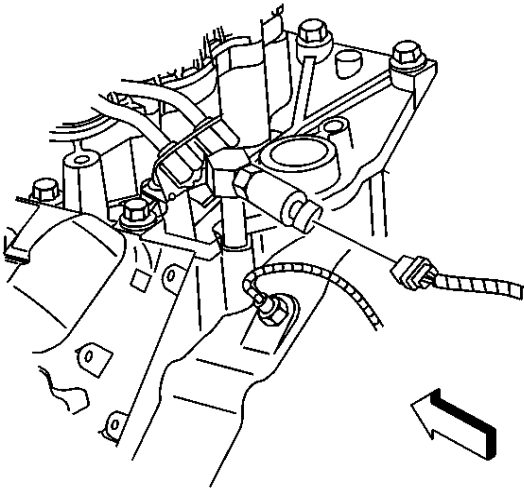

4. Connect the engine oil pressure sensor harness connector.

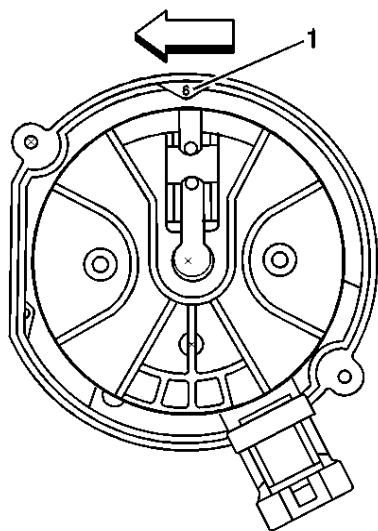

Important

The proper CKP/CMP correlation will be lost if the rotor is not reinstalled in the same exact position. A DTC P1345 will result from improper distributor shaft alignment.

5. Align the rotor in its original position in relation to the distributor base (1).

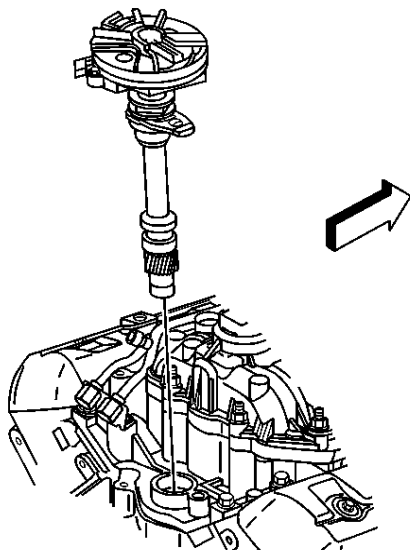

6. Install the distributor assembly using a new distributor gasket.

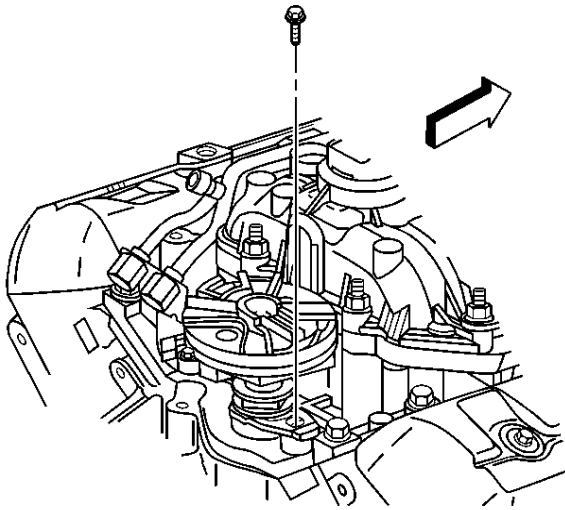

7. Install the distributor mounting bolt.

Tighten

Tighten the bolt to 25 N·m (18 lb ft)

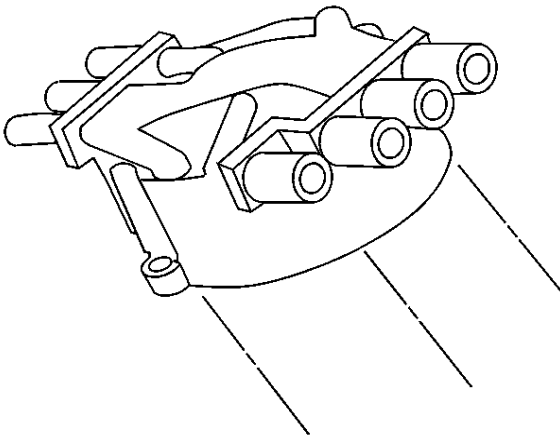

8. Install the distributor cap.

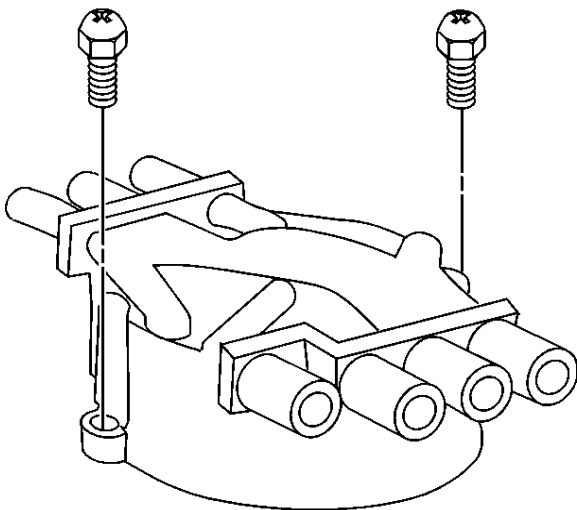

9. Install new distributor cap screws.

Tighten

Tighten the screws to 2.4 N·m (21 lb in)

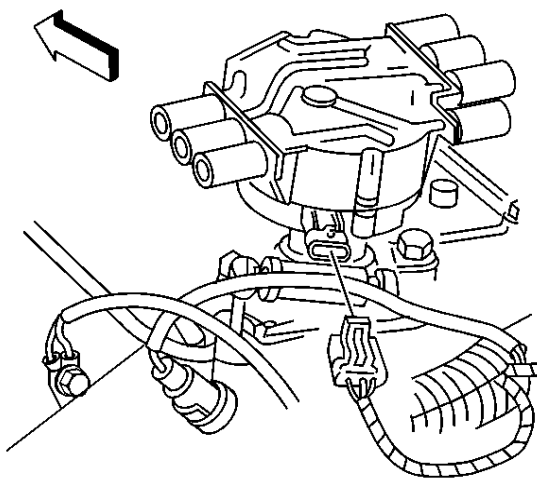

10. Connect the CMP sensor harness connector.

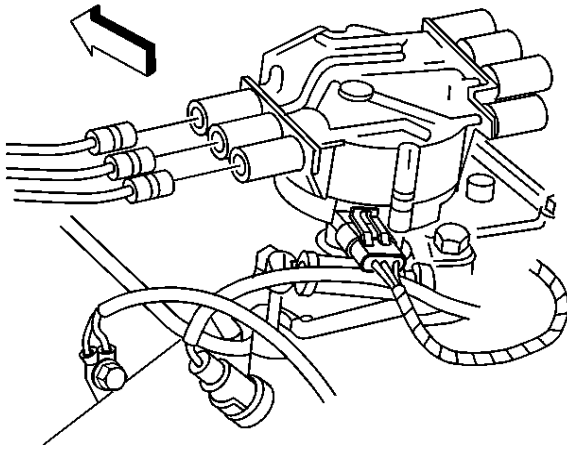

11. Connect the spark plug wires and the ignition coil wire.
12. Connect the negative battery cable.

[<- Back](#)[Forward ->](#)

Document ID# 443619
1999 Chevrolet/Geo Blazer - 4WD

[Print](#)