

Transfer Case Control Schematics (Cell 38: Power and Ground)

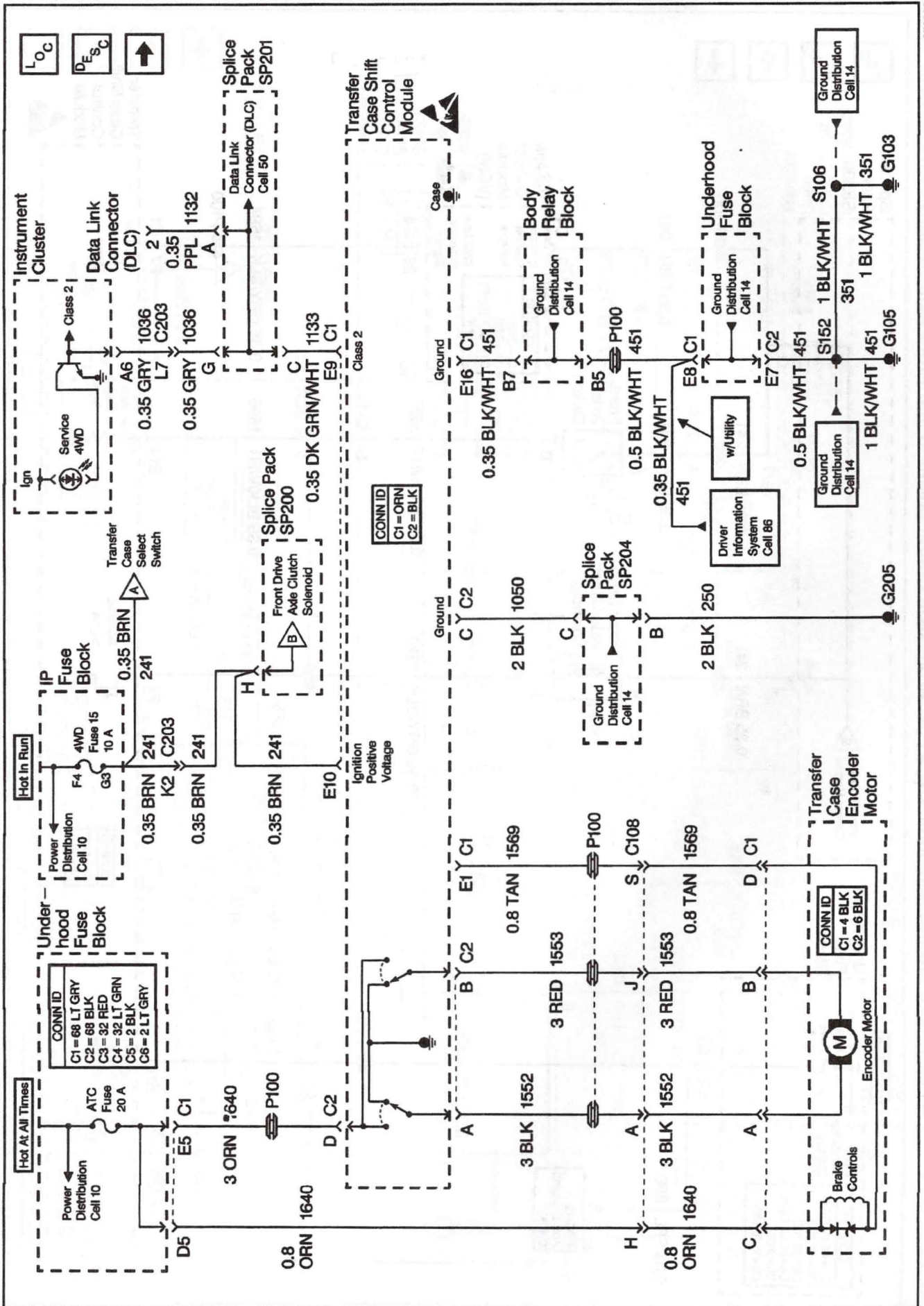

Transfer Case Control Schematics (Cell 38: Front Axle Clutch Solenoid and Front Axle Switch)

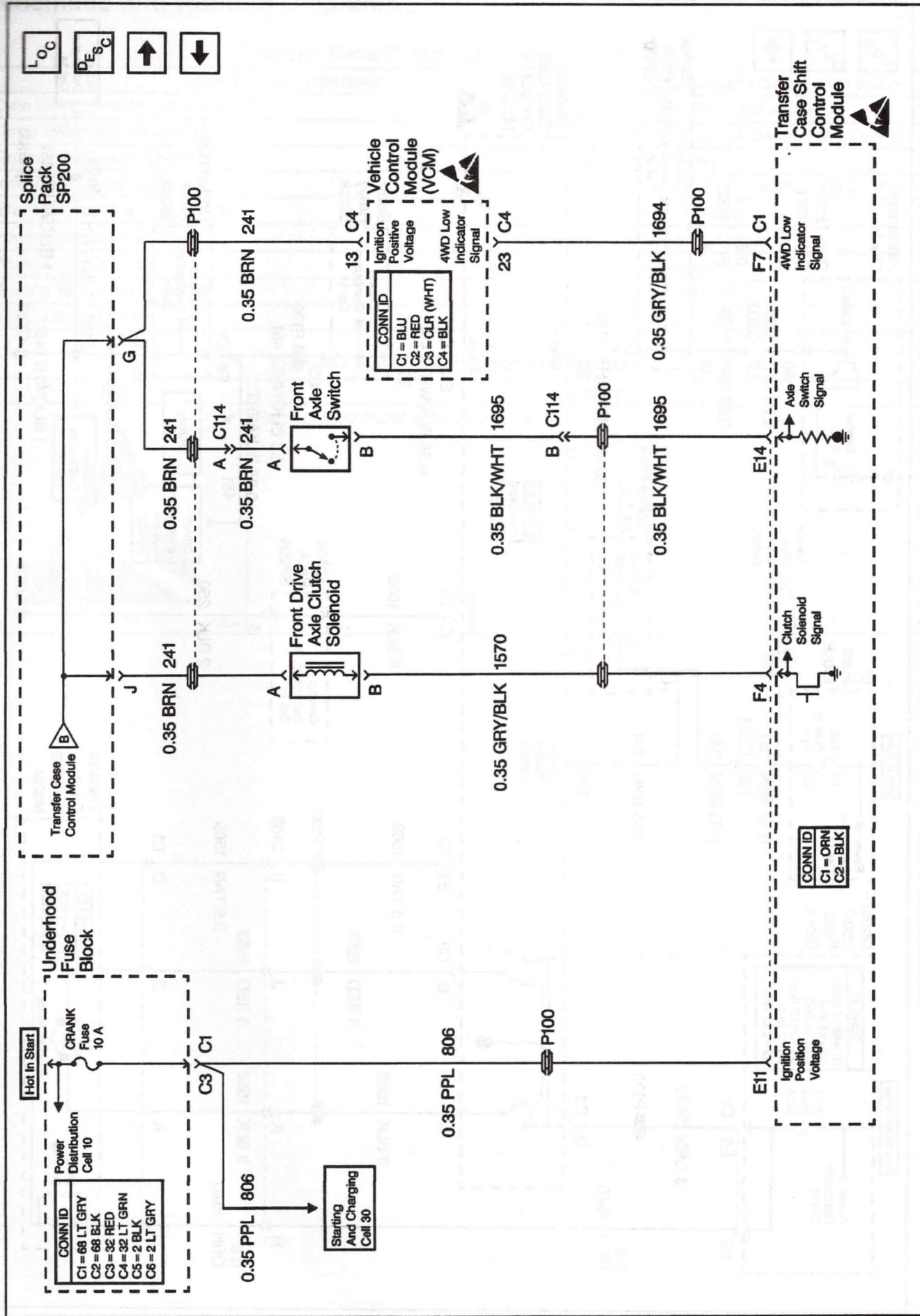

Transfer Case Control Schematics (Cell 38: Transfer Case Select Switch)

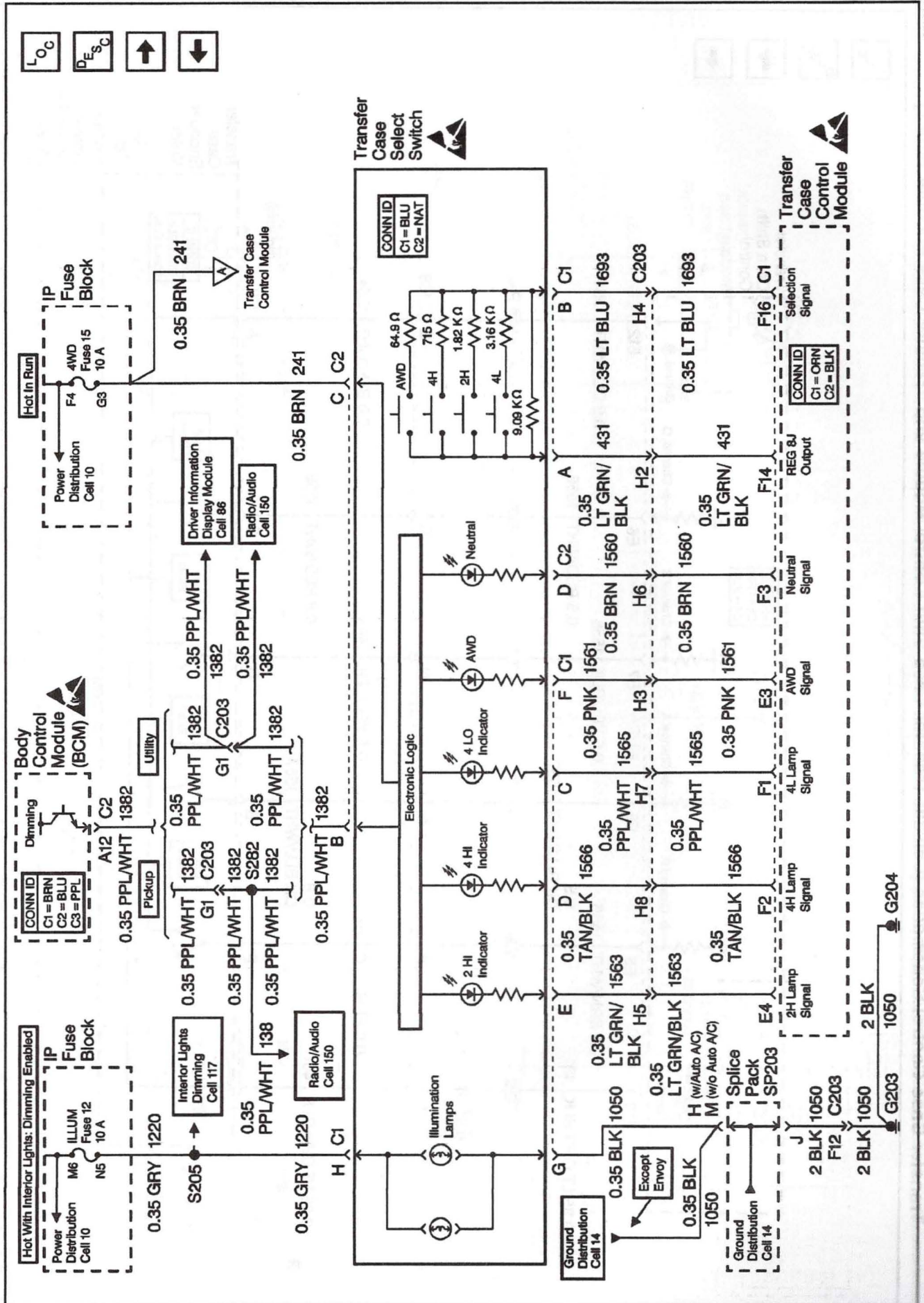

Transfer Case Control Schematics (Cell 38: Transfer Case Shift Control Module and Transfer Case Encoder Motor)

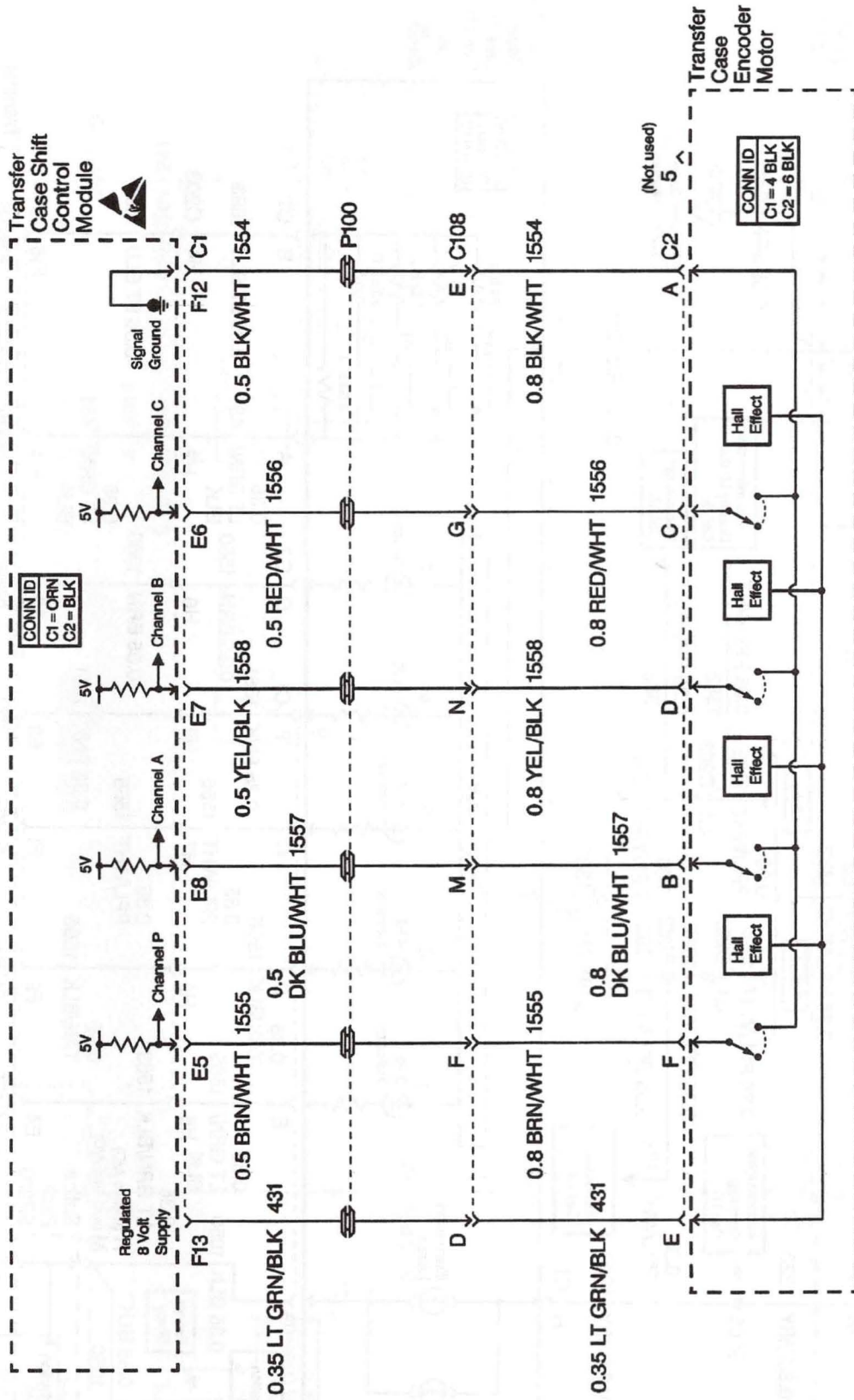

Transfer Case Control Schematics (Cell 38: Speed Sensors)

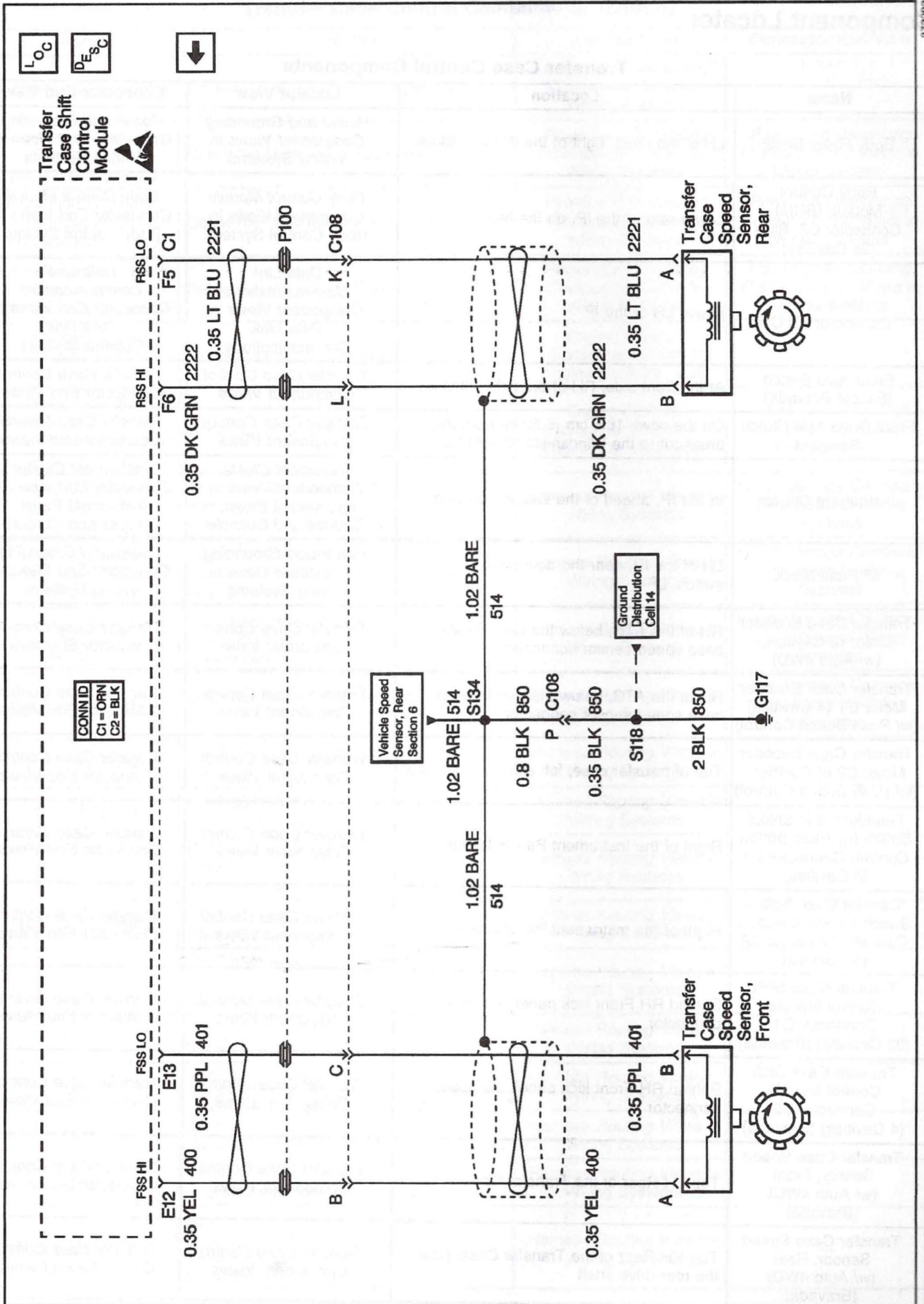

**Transfer Case Control Connector
End Views**

**Transfer Case Shift Control Module
Connector C1**

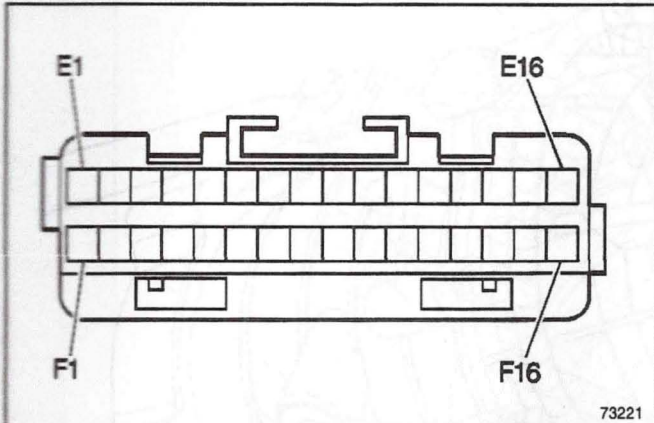

Connector Part Information		<ul style="list-style-type: none"> • 12052107 • 16 Way F Micro-Pack 100 Series (ORN) 	
Pin	Wire Color	Circuit No.	Function
E1	Tan	1569	Transfer Case Lock Solenoid Output
E2	—	—	Not Used
E3	PNK	1561	AWD/4WD Indicator Lamp Output
E4	Lt GRN/BLK	1563	2 HI Indicator Lamp Output
E5	BRN/WHT	1555	Transfer Case Position Switch Encoder Signal
E6	RED/WHT	1556	Transfer Case Position Switch Encoder Signal
E7	YEL/BLK	1558	Transfer Case Position Switch Encoder Signal
E8	DK BLU/WHT	1557	Transfer Case Position Switch Encoder Signal
E9	DK GRN/WHT	1133	Class 2 Serial Data Signal
E10	BRN	241	Fuse Output - Ignition 3 - Type III Fuse
E11	PPL	806	Fuse Output - Crank - Type III Fuse
E12	YEL	400	Vehicle Speed Sensor Signal
E13	PPL	401	Vehicle Speed Sensor Return
E14	BLK/WHT	1695	Four Wheel Drive Front Wheel Lock Telltale

**Transfer Case Shift Control Module
Connector C1 (cont'd)**

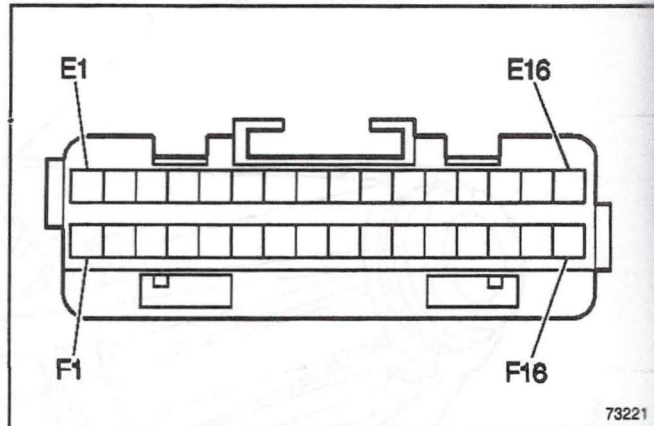

Connector Part Information		<ul style="list-style-type: none"> • 12052107 • 16 Way F Micro-Pack 100 Series (ORN) 	
Pin	Wire Color	Circuit No.	Function
E15	—	—	Not Used
E16	BLK/WHT	451	Engine Control Module Ground
F1	PPL/WHT	1565	4 LO Indicator Lamp Output
F2	TAN/BLK	1566	4 HI Indicator Lamp Output
F3	BRN	1560	Neutral Indicator Lamp Output
F4	GRA/BLK	1570	Front Axle Actuator Output
F5	LT BLU	2221	Vehicle Speed Sensor Signal
F6	DK GRN	2222	Vehicle Speed Sensor Return
F7	GRA/BLK	1694	Four Wheel Drive Switch Signal - Low
F8 - F11	—	—	Not Used
F12	BLK/WHT	1554	Transfer Case Encoder Signal Return
F13	LT GRN/BLK	431	Reference Voltage Feed - 8 Volt Reference
F14	LT GRN/BLK	431	Reference Voltage Feed - 8 Volt Reference
F15	—	—	Not Used
F16	LT BLU	1693	Four Wheel Drive Switch Signal

Transfer Case Shift Control Module Connector C2

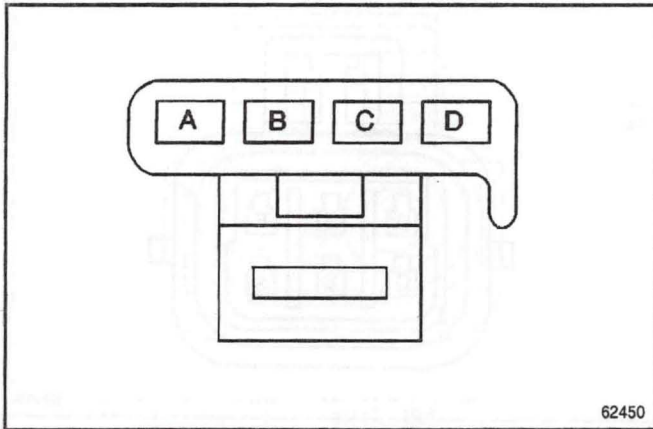

62450

Connector Part Information		<ul style="list-style-type: none"> • 12052856 • 4 Way F Metri-Pack 280 Series (BLK) 	
Pin	Wire Color	Circuit No.	Function
A	BLK	1552	Transfer Case Motor Feed - Clockwise
B	RED	1553	Transfer Case Motor Feed - Counterclockwise
C	BLK	1050	Ground
D	ORG	1640	Fuse Output - Battery - Type III Fuse

Transfer Case Select Switch Connector C1 (cont'd)

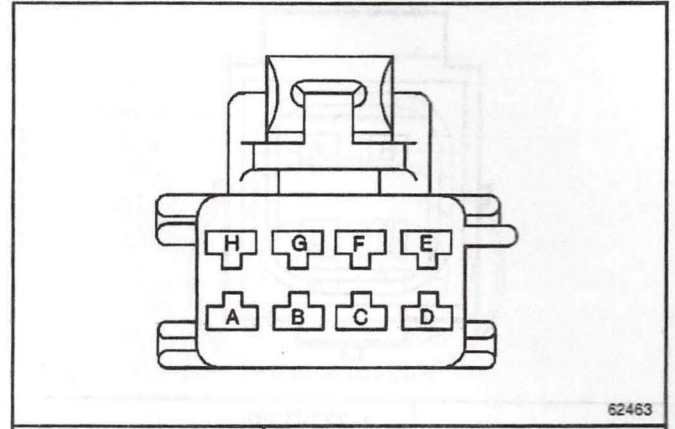

62463

Connector Part Information		<ul style="list-style-type: none"> • 12064766 • 8 Way F Metri-Pack 150 Series (BLU) 	
Pin	Wire Color	Circuit No.	Function
E	LT GRN/BLK	1563	2 HI Indicator Lamp Output
F	PNK	1561	AWD/4WD Indicator Lamp Output
G	BLK	1050	Ground
H	GRA	1220	Fuse Output - IP Lamps - Type III

Transfer Case Select Switch Connector C1

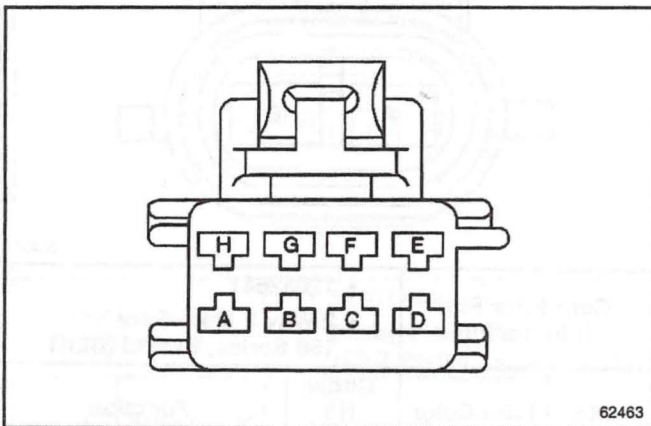

62463

Connector Part Information		<ul style="list-style-type: none"> • 12064766 • 8 Way F Metri-Pack 150 Series (BLU) 	
Pin	Wire Color	Circuit No.	Function
A	LT GRN/BLK	431	Reference Voltage Feed - 8 Volt Reference
B	LT BLU	1693	Four Wheel Drive Switch Signal
C	PPL/WHT	1565	4 LO Indicator Lamp Output
D	TAN/BLK	1566	4 HI Indicator Lamp Output

Transfer Case Select Switch Connector C2

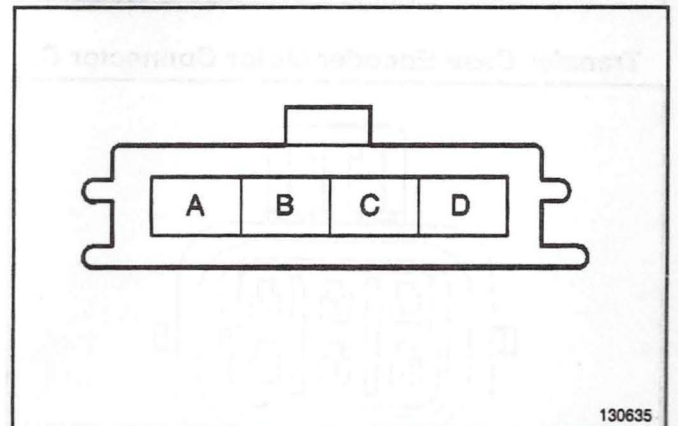

130635

Connector Part Information		<ul style="list-style-type: none"> • 12045813 • 4 Way F Metri-Pack 150 Series (NAT) 	
Pin	Wire Color	Circuit No.	Function
A	—	—	Not Used
B	PPL/WHT	1382	LED Dimming Signal
C	BRN	241	Fuse Output - Ignition 3 - Type III Fuse
D	BRN	1560	Neutral Indicator Lamp Output

Transfer Case Encoder Motor Connector C1

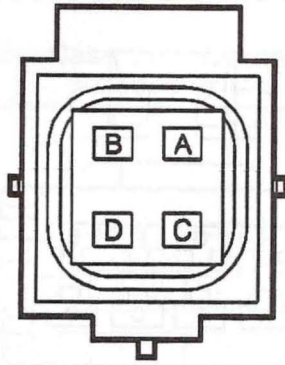

365977

Connector Part Information		<ul style="list-style-type: none"> • 12191399 • 4 Way F Metri-Pack 280 Series, Flexlock, Sealed (BLK) 	
Pin	Wire Color	Circuit No.	Function
A	BLK	1552	Transfer Case Motor Feed - Clockwise
B	RED	1553	Transfer Case Motor Feed - Counterclockwise
C	ORN	1640	Fuse Output - Battery - Type III Fuse
D	TAN	1569	Transfer Case Lock Solenoid Output

Transfer Case Encoder Motor Connector C2

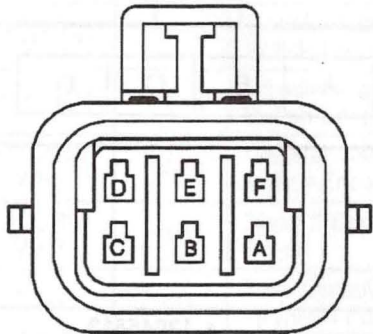

62449

Connector Part Information		<ul style="list-style-type: none"> • 12052848 • 6 Way F Metri-Pack 150 Series, Sealed (BLK) 	
Pin	Wire Color	Circuit No.	Function
A	BLK/WHT	1554	Transfer Case Encoder Signal Return
B	DK BLU/WHT	1557	Transfer Case Position Switch Encoder Signal
C	RED/WHT	1556	Transfer Case Position Switch Encoder Signal
D	YEL/BLK	1558	Transfer Case Position Switch Encoder Signal

Transfer Case Encoder Motor Connector C2 (cont'd)

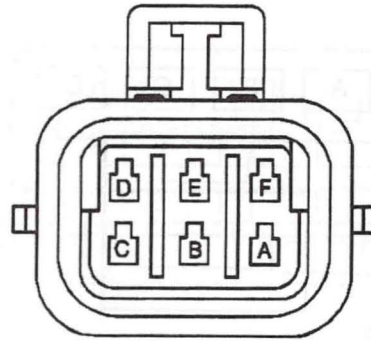

62449

Connector Part Information		<ul style="list-style-type: none"> • 12052848 • 6 Way F Metri-Pack 150 Series, Sealed (BLK) 	
Pin	Wire Color	Circuit No.	Function
E	LT GRN/BLK	431	Reference Voltage Feed - 8 Volt Reference
F	BRN/WHT	1555	Transfer Case Position Switch Encoder Signal

Front Drive Axle Clutch Solenoid Connector

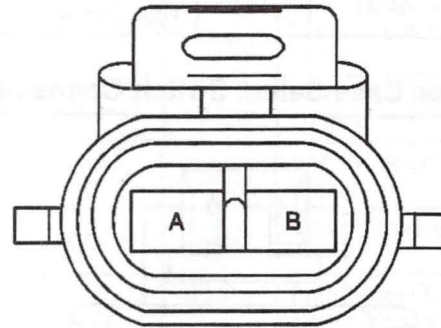

35437

Connector Part Information		<ul style="list-style-type: none"> • 12052641 • 2 Way F Metri-Pack 150 Series, Sealed (BLK) 	
Pin	Wire Color	Circuit No.	Function
A	BRN	241	Fuse Output - Ignition 3 - Type III Fuse
B	GRA/BLK	1570	Front Axle Actuator Output

Front Axle Switch Connector

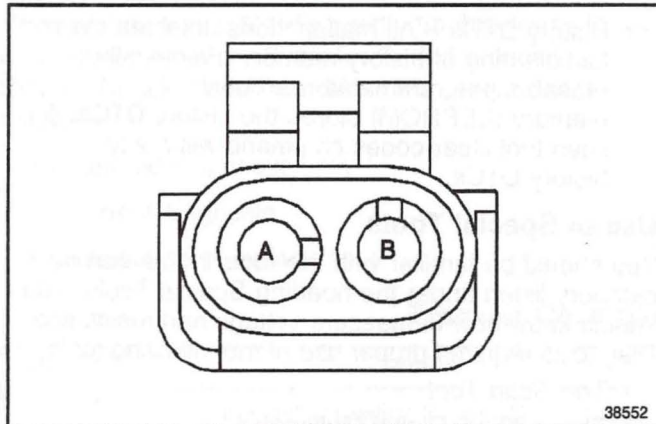

38552

Connector Part Information		<ul style="list-style-type: none"> • 12103584 • 2 Way F Weather Pack Connector (BRN) 	
Pin	Wire Color	Circuit No.	Function
A	BRN	241	Fuse Output - Ignition 3 - Type III Fuse
B	BLK/WHT	1695	Four Wheel Drive Front Wheel Lock Telltale

Rear Transfer Case Speed Sensor Connector

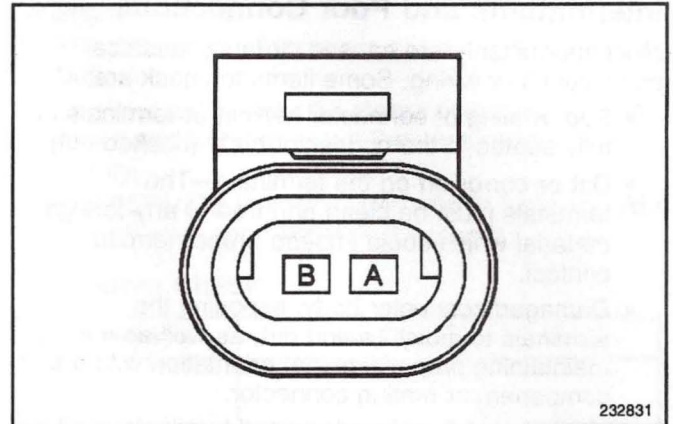

232831

Connector Part Information		<ul style="list-style-type: none"> • 12162194 • 2 Way F Metri-Pack 150.2 Series, Sealed (BLK) 	
Pin	Wire Color	Circuit No.	Function
A	LT BLU	2221	Vehicle Speed Sensor Signal
B	DK GRN	2222	Vehicle Speed Sensor Return

Front Transfer Case Speed Sensor Connector

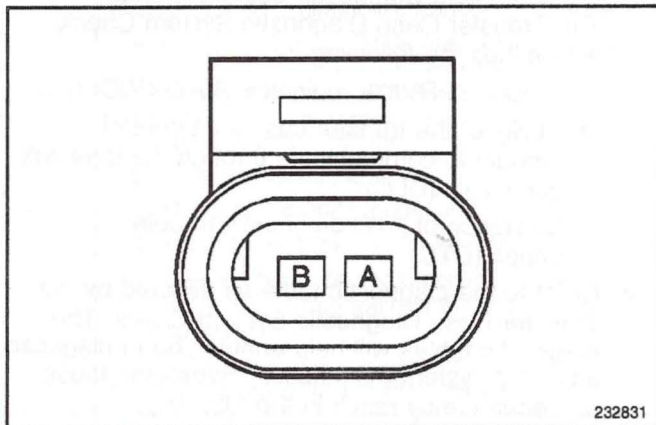

232831

Connector Part Information		<ul style="list-style-type: none"> • 12162194 • 2 Way F Metri-Pack 150.2 Series, Sealed (BLK) 	
Pin	Wire Color	Circuit No.	Function
A	YEL	400	Vehicle Speed Sensor Signal
B	PPL	401	Vehicle Speed Sensor Return