

<- Back

Forward ->

Document ID# 240418
1998 Chevrolet/Geo Blazer - 4WD

Print

DTC P0121 Throttle Position (TP) Sensor Performance

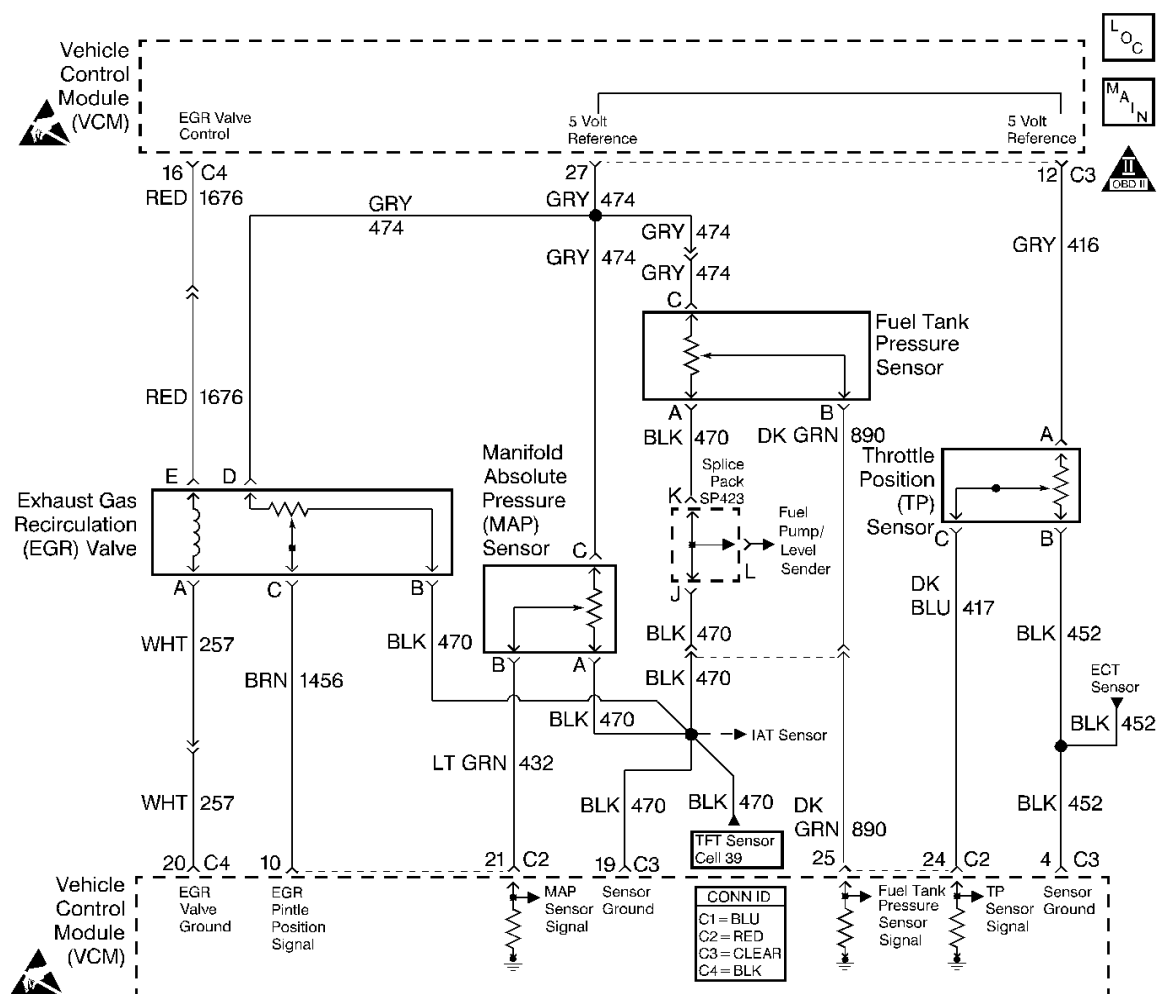

Circuit Description

The throttle position (TP) sensor is a potentiometer. The control module supplies the TP sensor a reference voltage, a signal, and ground circuits. When the throttle is depressed, the TP sensor signal rises to near the reference voltage. When the throttle is released, the TP sensor signal decreases from the reference voltage. The control module monitors the TP sensor signal circuit voltage in order to determine the throttle blade angle, or opening.

This DTC determines if the TP sensor signal input to the VCM does not closely match what the predicted

value for the TP sensor should be. The VCM calculates what the TP signal voltage should be based on engine RPM. If the TP sensor voltage and the predicted TP sensor values do not closely match, this DTC will be set.

Conditions for Running the DTC

- DTC P0122 not active
- No active IAC DTCs
- No active MAP sensor DTCs
- The engine is running.
- BARO not in default
- The throttle position is steady.

Conditions for Setting the DTC

The calculated throttle position is less than the actual throttle position for more than 5 seconds.

Action Taken When the DTC Sets

- The control module illuminates the malfunction indicator lamp (MIL) if a failure is detected during 2 consecutive key cycles.
- The control module sets the DTC and records the operating conditions at the time the diagnostic failed. The failure information is stored in the scan tool Freeze Frame/Failure Records.

Conditions for Clearing the MIL or DTC

- The control module turns OFF the MIL after 3 consecutive drive trips when the test has run and passed.
- A history DTC will clear if no fault conditions have been detected for 40 warm-up cycles. A warm-up cycle occurs when the coolant temperature has risen 22°C (40°F) from the startup coolant temperature and the engine coolant reaches a temperature that is more than 70°C (158°F) during the same ignition cycle.
- Use a scan tool in order to clear the DTCs.

Diagnostic Aids

The scan tool displays the throttle position in volts. It should display about 0.45 volts to 0.85 volts with the throttle closed and the ignition ON or at idle. The voltage should increase at a steady rate as the throttle is moved toward Wide Open Throttle (WOT).

The scan tool will read the throttle angle percentage. 0 percent at closed throttle, 100 percent at Wide Open Throttle (WOT). A MAP related DTC could set if the TP throttle angle is skewed or stuck at a value of less than 20 percent.

Check the condition of the connector and sensor terminals for moisture or corrosion, and clean or replace as necessary. If corrosion is found, check the condition of the connector seal and repair or replace as necessary. If DTC P0121 is intermittent, refer to [Symptoms](#).

Excessive throttle cable or cruise control cable tension could result in this DTC.

An intermittent may be caused by any of the following conditions:

- A poor connection
- Rubbed through wire insulation
- A broken wire inside the insulation

Thoroughly check any circuitry that is suspected of causing the intermittent complaint. Refer to [Intermittents and Poor Connections Diagnosis](#) in Wiring Systems.

If a repair is necessary, refer to [Wiring Repairs](#) or [Connector Repairs](#) in Wiring Systems.

Test Description

The numbers below refer to the step numbers on the diagnostic table.

- The TP sensor has an auto zeroing feature. If the voltage reading is within the range of about 0.2-0.9 volt, the VCM uses that value as a closed throttle. If the reading is out of the auto zero range at the closed throttle, check for a binding throttle shaft or damaged linkage. If the throttle shaft and the linkage are okay, continue with the diagnosis.
- The TP sensor throttle angle should range smoothly from 0-100 percent when the throttle is slowly depressed to the wide open throttle (WOT) position. If not, a skewed out of range TP sensor, low reference voltage or a poor connection could be possible causes.
- With the TP sensor disconnected, the TP sensor signal voltage should go low if the VCM and the wiring are okay and a DTC P0122 may set.
- Reference voltage less than 4.5 volts could cause a poor TP performance condition. Be sure to check both 5 volt reference circuits for conditions that could cause low voltage on the TP sensor circuit.
- The throttle shaft, throttle linkage or accelerator cable not closing due to sticking or binding could cause a TP sensor poor performance condition.

| Step | Action | Value(s) | Yes | No |
|----------|--|----------|------------------------------|---|
| 1 | <p>Important</p> <p>Before clearing the DTCs, use the scan tool Capture Info to save the Freeze Frame and Failure Records for reference. The control module's data is deleted once the Clear Info function is used.</p> <p>Did you perform the Powertrain On-Board Diagnostic (OBD) System Check?</p> | -- | Go to Step 2 | Go to Powertrain On Board Diagnostic (OBD) System Check |
| <u>2</u> | <p>1. Install the scan tool.</p> <p>2. Turn ON the ignition leaving the engine OFF.</p> <p>Does the scan tool display the throttle angle more than the specified value?</p> | 2% | Go to Step 6 | Go to Step 3 |
| <u>3</u> | <p>Important</p> | 0-100% | Go to Step 4 | Go to Step 10 |

| | | | | |
|----|--|-------|--------------------------------|-------------------------------|
| | <p>The engine must remain OFF for this step.</p> <p>Depress the throttle slowly to wide open throttle (WOT) while watching the throttle angle increase through the specified range.</p> <p>Does the TP sensor range reach the maximum specified value?</p> | | | |
| 4 | <p>Release the throttle.</p> <p>Does the scan tool display the throttle angle more than the specified value?</p> | 2% | Go to Step 6 | Go to Step 5 |
| 5 | <p>The DTC is intermittent.</p> <p>Are any additional DTCs set?</p> | -- | Go to the applicable DTC table | Go to Diagnostic Aids |
| 6 | <p>Disconnect the TP sensor harness connector.</p> <p>Does the scan tool display the TP sensor at the specified value?</p> | 0 V | Go to Step 7 | Go to Step 9 |
| 7 | <p>1. Turn OFF the ignition.</p> <p>2. Probe the TP sensor ground circuit with a test lamp connected to B+.</p> <p>Is the test lamp ON?</p> | -- | Go to Step 8 | Go to Step 14 |
| 8 | <p>1. Turn ON the ignition leaving the engine OFF.</p> <p>2. Probe the TP sensor 5 volt reference circuit at the TP sensor harness connector with a J 39200 DMM connected to a ground.</p> <p>Is the voltage more than the specified value?</p> | 5.2 V | Go to Step 15 | Go to Step 19 |
| 9 | <p>1. Turn OFF the ignition.</p> <p>2. Disconnect the VCM C2 connector.</p> <p>3. Turn ON the ignition leaving the engine OFF.</p> <p>4. Probe the TP sensor signal circuit at the TP sensor harness connector with a J 39200 DMM connected to a ground.</p> <p>Is the voltage more than the specified value?</p> | 0 V | Go to Step 13 | Go to Step 22 |
| 10 | <p>1. Turn OFF the ignition.</p> <p>2. Disconnect the TP sensor harness connector.</p> <p>3. Jumper the TP sensor 5 volt reference circuit to the TP sensor signal circuit at the TP sensor harness connector.</p> <p>4. Turn ON the ignition leaving the engine OFF.</p> <p>Does the scan tool display the throttle angle at the specified value?</p> | 100% | Go to Step 17 | Go to Step 11 |
| 11 | <p>1. Turn ON the ignition leaving the engine OFF.</p> <p>2. Probe the TP sensor 5 volt reference circuit with a J</p> | 5.2 V | Go to Step 12 | Go to Step 16 |

| | | | | |
|--------------------|---|--------|-------------------------------|-------------------------------|
| | <p>39200 DMM connected to a ground.</p> <p>Is the voltage near the specified value?</p> | | | |
| 12 | <p>1. Turn OFF the ignition. 2. Disconnect the VCM C2 connector. 3. Check the resistance in the TP sensor signal circuit between the TP sensor harness connector and the VCM connector with a J 39200 DMM.</p> <p>Is the resistance near the specified value?</p> | 0 ohms | Go to Step 22 | Go to Step 18 |
| 13 | <p>Repair the short to voltage on the TP sensor signal circuit. Refer to Wiring Repairs in Wiring Systems.</p> <p>Is the action complete?</p> | -- | Go to Step 24 | -- |
| 14 | <p>Repair the open in the TP sensor ground circuit. Refer to Wiring Repairs in Wiring Systems.</p> <p>Is the action complete?</p> | -- | Go to Step 24 | -- |
| 15 | <p>Repair the short to voltage in the 5 volt reference circuit. Refer to Wiring Repairs in Wiring Systems.</p> <p>Is the action complete?</p> | -- | Go to Step 24 | -- |
| 16 | <p>Repair the low voltage condition on the 5 volt reference circuit. Refer to Wiring Repairs in Wiring Systems.</p> <p>Is the action complete?</p> | -- | Go to Step 24 | -- |
| 17 | <p>Check for a poor connection at the TP sensor.</p> <p>Did you find a problem?</p> | -- | Go to Step 18 | Go to Step 19 |
| 18 | <p>Repair the circuit as necessary. Refer to Wiring Repairs or Connector Repairs in Wiring Systems.</p> <p>Is the action complete?</p> | -- | Go to Step 24 | -- |
| 19 | <p>Check the throttle shaft, linkage, throttle and cruise cables for the following conditions:</p> <ul style="list-style-type: none"> • Binding • Sticking <p>Did you find a problem?</p> | -- | Go to Step 20 | Go to Step 21 |
| 20 | <p>Repair the throttle shaft, linkage, or cables as necessary.</p> <p>Is the action complete?</p> | -- | Go to Step 24 | -- |
| 21 | <p>Replace the TP sensor. Refer to Throttle Position (TP) Sensor Replacement .</p> <p>Is the action complete?</p> | -- | Go to Step 24 | -- |

| | | | | |
|----|--|----|--------------------------------|-------------------------------|
| 22 | <p>Check for a poor connection at the VCM. Repair as necessary. Refer to Connector Repairs in Wiring Systems.</p> <p>Did you find a problem?</p> | -- | Go to Step 24 | Go to Step 23 |
| 23 | <ol style="list-style-type: none"> 1. Replace the VCM. 2. Program the new VCM. Refer to VCM Replacement/Programming . 3. Perform the VTD Password Learn Procedure. Refer to Password Learn Procedure . 4. Perform the CKP System Variation Learn Procedure. Refer to CKP System Variation Learn Procedure . <p>Is the action complete?</p> | -- | Go to Step 24 | -- |
| 24 | <ol style="list-style-type: none"> 1. Using the scan tool, clear the DTCs. 2. Start the engine. 3. Allow the engine to idle until the engine reaches normal operating temperature. 4. Select DTC and the Specific DTC function. 5. Enter the DTC number which was set. 6. Operate the vehicle, with the Conditions for Setting this DTC, until the scan tool indicates the diagnostic Ran. <p>Does the scan tool indicate the diagnostic Passed?</p> | -- | Go to Step 25 | Go to Step 2 |
| 25 | <p>Does the scan tool display any additional undiagnosed DTCs?</p> | -- | Go to the applicable DTC table | System OK |

< - Back

Forward ->

Document ID# 240418
1998 Chevrolet/Geo Blazer - 4WD

Print