

Hydraulic Brake System Bleeding

Notice: Brake fluid will damage electrical connections and painted surfaces. Use shop cloths, suitable containers, and fender covers to prevent brake fluid from contacting these areas. Always re-seal and wipe off brake fluid containers to prevent spills.

If air has entered the hydraulic brake system, bleed the system. You may need to bleed the hydraulic brake system at all four wheels due to one of the following conditions:

- Air entered the system due to a low fluid level.
- The brake pipes have been disconnected at the master cylinder.
- The brake pipes have been disconnected at the combination valve.
- The brake pipes have been disconnected at the Brake Pressure Modulator Valve (BPMV).

If a pipe is disconnected at one wheel, then only bleed that wheel.

If the master cylinder has been removed, bench bleed the master cylinder before installing it on the vehicle in order to reduce the time required to bleed the system. Refer to *Master Cylinder Bench Bleeding*.

If the BPMV has been replaced or has air trapped in it, refer to *Brake Pressure Modulator Valve Replacement* in Antilock Brake System.

Manual Bleeding

Tools Required

- J 28434 Wheel Cylinder Bleeder Wrench
- J 21472 Brake Bleeder Wrench

1. Apply the brakes several times with the ignition OFF in order to relieve the brake vacuum reserve.
2. Fill the master cylinder reservoirs with DOT 3 motor vehicle brake fluid.
3. Maintain the fluid level during bleeding.
4. If the master cylinder has air in the bore, bleed the master cylinder using the following procedure:
 - 4.1. Disconnect the forward brake pipe connector at the master cylinder.
 - 4.2. Allow the brake fluid to flow from the connector port.
 - 4.3. Connect the brake pipe connector. Do not tighten the brake pipe connector.
 - 4.4. Slowly apply the brake pedal and allow the air to bleed from the loose connector.
 - 4.5. Tighten the connector before releasing the brake pedal.
 - 4.6. Wait 15 seconds.
 - 4.7. Repeat this sequence, including the 15 second wait, until all air is purged from the master cylinder bore.
 - 4.8. Repeat this procedure for the rear brake pipe after you purge all the air from the forward pipe connection.

5. If the brake pressure modulator valve of the antilock brake system is replaced or if you suspect that air is trapped inside, bleed the brake pressure modulator valve next. Refer to *Brake Pressure Modulator Valve Replacement* in Antilock Brake System.
 6. Follow this sequence if it is necessary to bleed all four wheels:
 - 6.1. Right rear wheel cylinder or caliper.
 - 6.2. Left rear wheel cylinder or caliper.
 - 6.3. Right front wheel caliper.
 - 6.4. Left front wheel caliper.
 7. Use J 28434 to bleed the wheel cylinders.
 - 7.1. Place the hex end of the wrench over the wheel cylinder bleeder valve.
 - 7.2. Immerse the opposite end of the hose into a clear container partially filled with clean brake fluid.
 8. Use J 21472 to bleed the calipers.
 - 8.1. Place the proper size hex end of the wrench over the caliper bleeder valve.
 - 8.2. Place a clear tube over the caliper bleeder valve.
 - 8.3. Immerse the opposite end of the hose into a clear container partially filled with clean brake fluid.
 9. Slowly apply the brake pedal one time and hold.
 10. Loosen the bleeder valve in order to purge the air from the wheel cylinder or caliper.
 11. Tighten the bleeder valve and slowly release the brake pedal.
 12. Wait 15 seconds.
- Notice:** Refer to *Fastener Notice* in Cautions and Notices.
13. Repeat this sequence, including the 15-second wait, until all air is purged from the wheel cylinder or caliper.
- Tighten**
- Tighten the bleeder valve to 7 N·m (62 lb in).
14. Repeat steps 7–13 at each wheel until the brake system is bled.
 15. Clean any brake fluid off the vehicle that may have gotten on it during the bleeding procedure.
 16. Inspect the brake pedal for sponginess, and inspect the brake warning lamp for an indication of unbalanced pressure. Repeat the bleeding procedure in order to correct either of these conditions.
 17. Fill the master cylinder reservoir to the proper level. Refer to *Master Cylinder Reservoir Filling*.

Pressure Bleeding

Use a diaphragm-type pressure bleeder. The pressure bleeder must have a rubber diaphragm between the air supply and the brake fluid. This prevents the following items from entering the hydraulic brake system:

- Air
- Moisture
- Oil
- Other contaminants

Tools Required

- J 35589 Master Cylinder Pressure Bleeder Adapter
- J 39177 Combination Valve Pressure Bleeding Tool
- J 28434 Wheel Cylinder Bleeder Wrench
- J 21472 Brake Bleeder Wrench

1. Fill the pressure bleeder tank at least 2/3 full of brake fluid.
2. Charge the pressure bleeder with 140–170 kPa (20–25 psi) air pressure.
3. Bleed the pressure bleeder each time fluid is added in order to remove any trapped air.
4. Use the J 39177 in order to depress and hold the valve stem on the combination valve.
5. Remove the master cylinder reservoir cap and install the master cylinder pressure bleeder adapter, J 35589, to the reservoir.
6. If the brake pressure modulator valve of the antilock brake system is replaced, or if you suspect that air is trapped inside, bleed the brake pressure modulator valve first. Refer to *Brake Pressure Modulator Valve Replacement* in Antilock Brake System.
7. Follow this sequence if it is necessary to bleed all four wheels:
 - 7.1. Right rear wheel cylinder or caliper.
 - 7.2. Left rear wheel cylinder or caliper.
 - 7.3. Right front wheel caliper.
 - 7.4. Left front wheel caliper.
8. Connect the hose from the pressure bleeder to the adapter at the master cylinder.
9. Open the tank valve.
10. Use J 28434 to bleed the wheel cylinders.
 - 10.1. Place the hex end of the wrench over the wheel cylinder bleeder valve.
 - 10.2. Immerse the opposite end of the hose into a clear container partially filled with clean brake fluid.

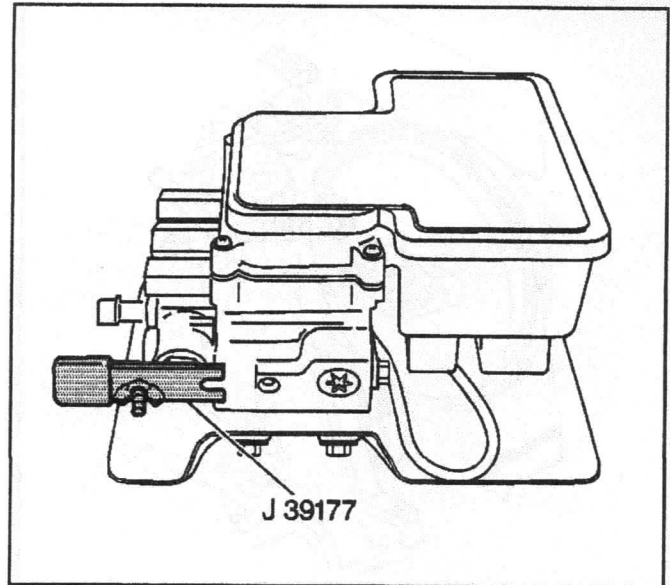

383536

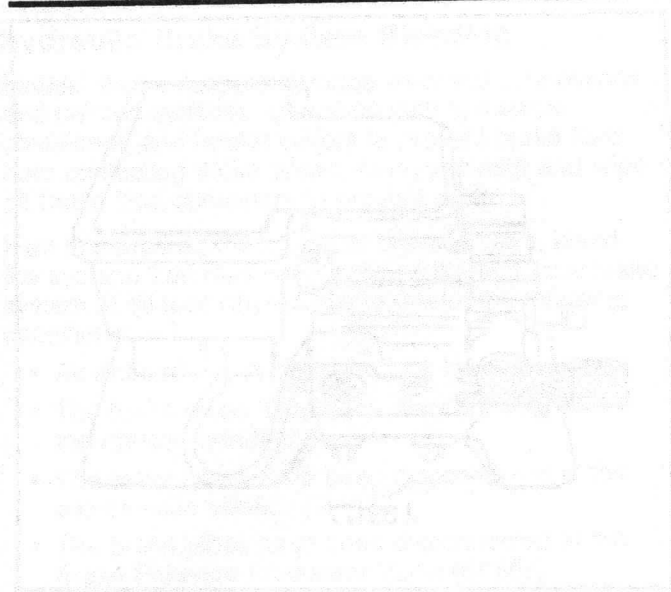

11. Use *J 21472* to bleed the calipers.
 - 11.1. Place the proper size hex end of the wrench over the caliper bleeder valve.
 - 11.2. Place a clear tube over the caliper bleeder valve.
 - 11.3. Immerse the opposite end of the hose into a clear container partially filled with clean brake fluid.

Notice: Refer to *Fastener Notice* in Cautions and Notices.

12. Slowly open the wheel cylinder or caliper bleeder valve at least $3/4$ of a turn. Allow the fluid to flow until you see no more air in the fluid.

Tighten

Tighten the wheel cylinder or caliper bleeder valve to 7 N·m (62 lb in).

13. Repeat steps 10–12 at each wheel until the brake system is bled.
14. Clean any brake fluid off the vehicle that may have gotten on it during the bleeding procedure.
15. Inspect the brake pedal for sponginess. Inspect the brake warning lamp for an indication of unbalanced pressure. Repeat the bleeding procedure in order to correct either of these conditions.
16. Disconnect the hose from the bleeder adapter.
17. Remove the bleeder adapter.
18. Fill the master cylinder to the proper level. Refer to *Master Cylinder Reservoir Filling*.
19. Install the master cylinder reservoir cap.

Hydraulic Brake System Flushing

Important: Flush the hydraulic brake system at each bleeder valve.

1. Open the bleeder valve $1\ 1/2$ turns.
2. Force brake fluid through the pipes, hoses, and bleeder valves until the brake fluid comes out clear in color. Refer to *Hydraulic Brake System Bleeding*.

Important: Inspect the master cylinder fluid level after you flush at each bleeder valve.

3. Refill the master cylinder as required.
4. After you flush the hydraulic brake system at each bleeder valve, fill the master cylinder to the correct fluid level. Refer to *Master Cylinder Reservoir Filling*.

Repair Instructions

ABS Bleed Procedure

Two Person Procedure

Important:

- Use the two-person bleed procedure under the following conditions:
 - Installing a new Electro-Hydraulic Control Unit (EHCU) or new Brake Pressure Modulator Valve (BPMV).
 - Air is trapped in the valve body
 - Do not drive the vehicle until the brake pedal feels firm.
 - Do not reuse brake fluid that is used during bleeding.
 - Use the vacuum, the pressure and the gravity bleeding procedures only for base brake bleeding.
1. Raise the vehicle in order to access the system bleed screws.
 2. Bleed the system at the right rear wheel first.
 3. Install a clear hose on the bleed screw.
 4. Immerse the opposite end of the hose into a container partially filled with clean DOT 3 brake fluid.

5. Open the bleed screw 1/2 to one full turn.
6. Slowly depress the brake pedal. While the pedal is depressed to its full extent, tighten the bleed screw.
7. Release the brake pedal and wait 10–15 seconds for the master cylinder pistons to return to the home position.
8. Repeat the previous steps for the remaining wheels. The brake fluid which is present at each bleed screw should be clean and free of air.
9. This procedure may use more than a pint of fluid per wheel. Check the master cylinder fluid level every four to six strokes of the brake pedal in order to avoid running the system dry.
10. Press the brake pedal firmly and run the *Scan Tool* Automated Bleed Procedure. Release the brake pedal between each test.
11. Bleed all four wheels again using Steps 3–9. This will remove the remaining air from the brake system.
12. Evaluate the feel of the brake pedal before attempting to drive the vehicle.
13. Bleed the system as many times as necessary in order to obtain the appropriate feel of the pedal.

Electronic Brake Control Module (EBCM) Replacement

Removal Procedure

Important: After installation, calibrate the new EBCM to the tire size that is appropriate to the vehicle. Refer to Tire Size Calibration and to Trim Level Calibration portions of *ABS Operation*.

Caution: Refer to *Battery Disconnect Caution in Cautions and Notices*.

1. Negative Battery Cable.
2. Remove the four T-25 Torx® screws (1) that fasten the EBCM to the BPMV.

Important: Do not use a tool to pry the EBCM or the BPMV. Excessive force will damage the EBCM.

3. Partially remove the EBCM (2) from the BPMV (4) enough to access the electrical connectors. Removal may require a light amount of force.
4. Disconnect the four electrical connectors from EBCM.
5. Fully remove the EBCM (2) from the BPMV (4).

Installation Procedure

Important: Do not reuse the old mounting screws. Always install new mounting screws with the new EBCM.

Important: Do not use RTV or any other type of sealant on the EBCM gasket or mating surfaces.

1. Connect the four electrical connectors to the EBCM.
2. Install EBCM (2) on to the BPMV (4).

Notice: Refer to *Fastener Notice* in Cautions and Notices.

3. Install the four new T-25 Torx® screws (1) in the EBCM (2).

Tighten

Tighten the four T-25 Torx® screws to 5 N·m (39 lb in) in an X-pattern.

4. Connect the negative battery cable.
5. Revise the tire calibration using the *Scan Tool*.
6. Return to *A Diagnostic System Check - ABS*.

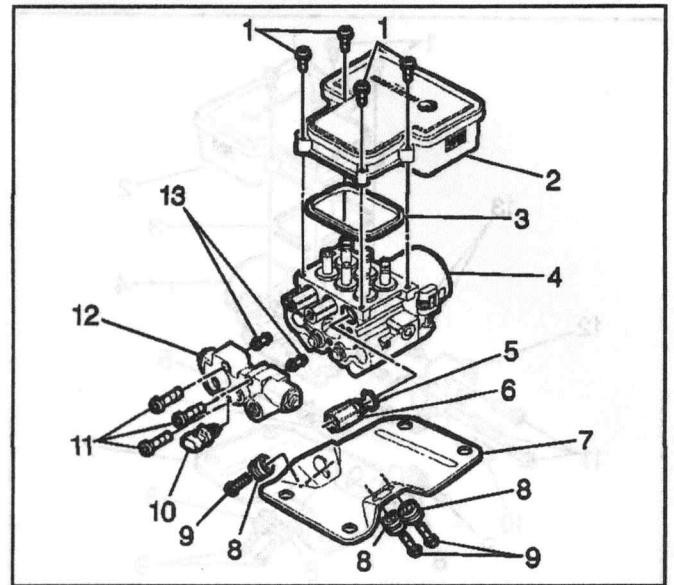

184208

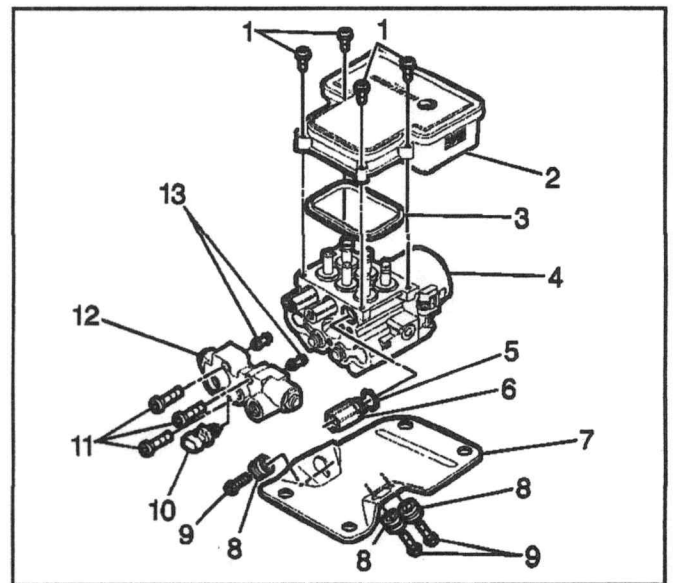

184208

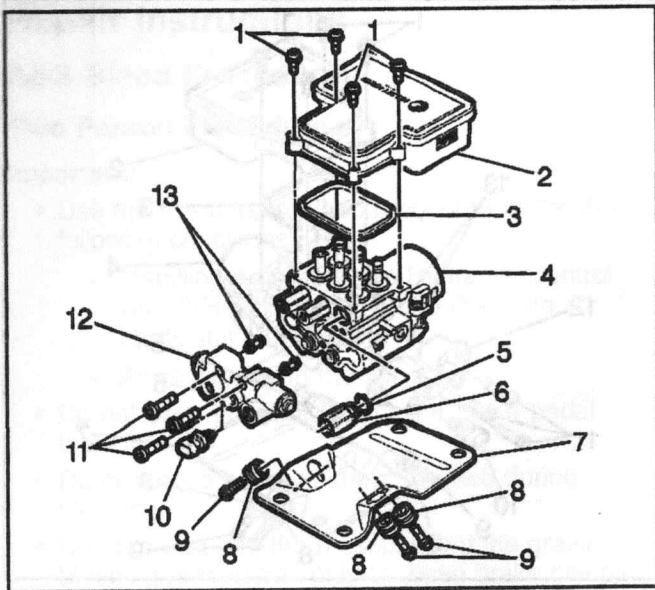

184208

Brake Pressure Modulator Valve Replacement

Removal Procedure

Caution: Refer to *Battery Disconnect Caution in Cautions and Notices.*

1. Disconnect the negative battery cable.
2. Remove the two fuse block mounting bolts from the EBCM bracket.
3. Disconnect the electrical connector from the combination valve (12).
4. Remove the front and rear brake pipes (from master cylinder) from the combination valve.
5. Remove the right front, left front and rear brake pipes from the tube adapters (6).
6. Remove the four 10 mm bolts (9) that fasten the EHCU bracket (7) to the vehicle mounting bracket.
7. Lift the EHCU partially out of the engine compartment.
8. Disconnect the four electrical connectors from the EBCM (2).
9. Fully remove the EHCU from the vehicle.
10. Remove the three Allen bolts (11) from the combination valve (12).
11. Remove the combination valve (12).

Important: Do not reuse the transfer tubes. Always install new transfer tubes.

12. Remove the two transfer tubes (13).
13. Remove the three 13 mm bolts (9) that fasten the bracket to the BPMV.
14. Remove the four T-25 Torx® bolts (1) from the EBCM.

Important: Do not use a tool to pry the EBCM or the BPMV. Excessive force will damage the EBCM.

15. Remove the EBCM (2) from the BPMV (4). Removal may require a light amount of force.

Installation Procedure

1. Install the new transfer tubes (13) into the combination valve into the combination valve (9).
2. Install the combination valve onto the BPMV (4).

Notice: Refer to *Fastener Notice* in Cautions and Notices.

3. Install the three Allen bolts (11) that fasten the combination valve (12) to the BPMV (4).

Tighten

Tighten the three Allen bolts to 8 N·m (6 lb ft), then to 16 N·m (12 lb ft).

Important: Do not reuse the old EBCM mounting bolts. Always install new mounting bolts with the new EBCM.

Important: Do not use RTV or any other type of sealant on the EBCM gasket or mating surfaces.

4. Install the EBCM gasket (3) onto the BPMV (4).
5. Ensure gasket alignment is correct.
6. Install EBCM (2) onto BPMV (4).
7. Install the four new EBCM bolts (1).

Tighten

Tighten the four bolts to 5 N·m (39 lb. in.) in an X-pattern.

8. Install EHCUC (4) to bracket.
9. Install the three BPMV (4) to bracket retaining bolts.

Tighten

Tighten the three bolts to 9 N·m (7 lb ft).

10. Connect the four electrical connectors to the EBCM.
11. Install the EHCUC to the vehicle frame.

Tighten

Tighten the three bolts to 25 N·m (20 lb ft).

12. Install the right front, left front and rear brake pipes to the tube adapters.

Tighten

Tighten the three brake pipe fittings to 29 N·m (22 lb ft).

13. Install the front and rear brake pipes (from master cylinder) to the combination valve.

Tighten

Tighten the three brake pipe fittings to 29 N·m (22 lb ft).

14. Connect the electrical connector to the combination valve.
15. Install the two fuse block mounting bolts from the EBCM bracket.
16. Connect the negative battery cable.

Important: Verify that the combination valve metering rod is depressed during bleeding.

17. Bleed the brake system. Refer to *ABS Bleed Procedure*.
18. Return to Diagnostic System Check.

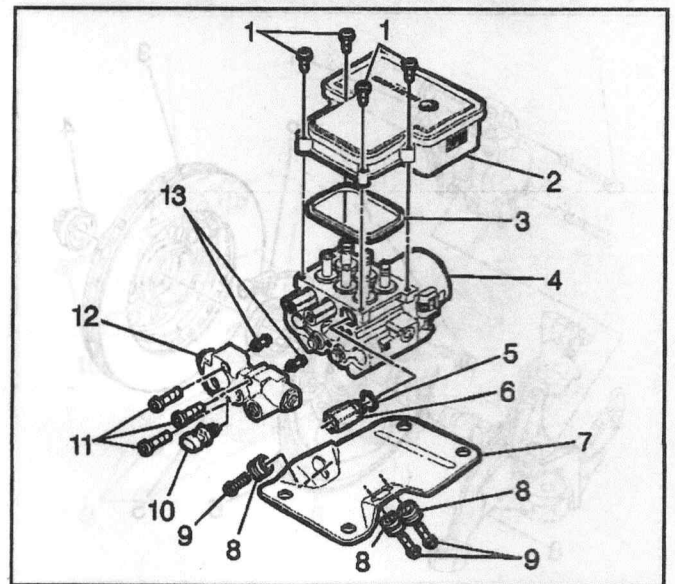

184208

