

Radio/Audio System Schematics (Cell 150: Power and Ground (Chevy/GMC))

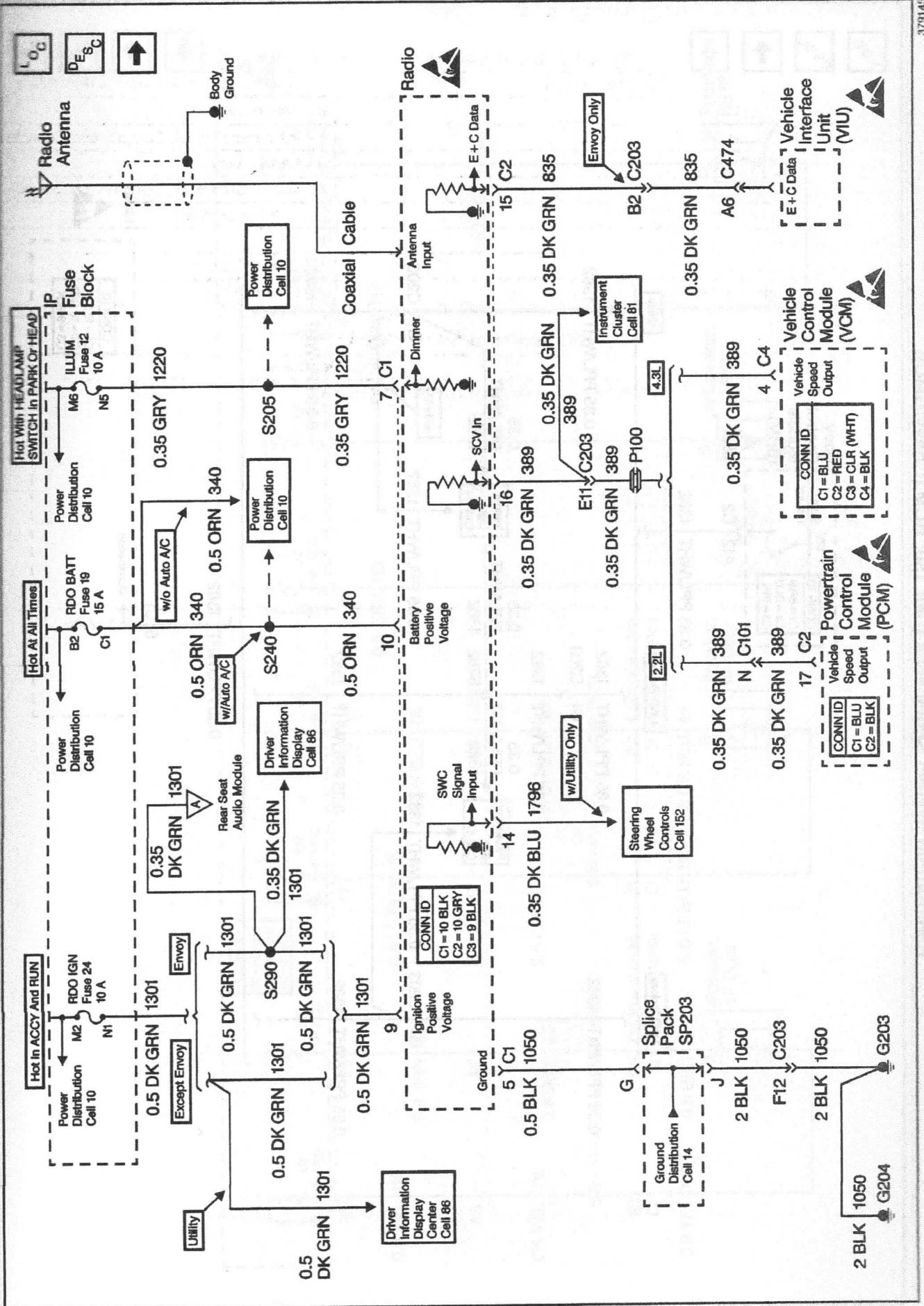

Steering Wheel Controls Schematics (Cell 152)

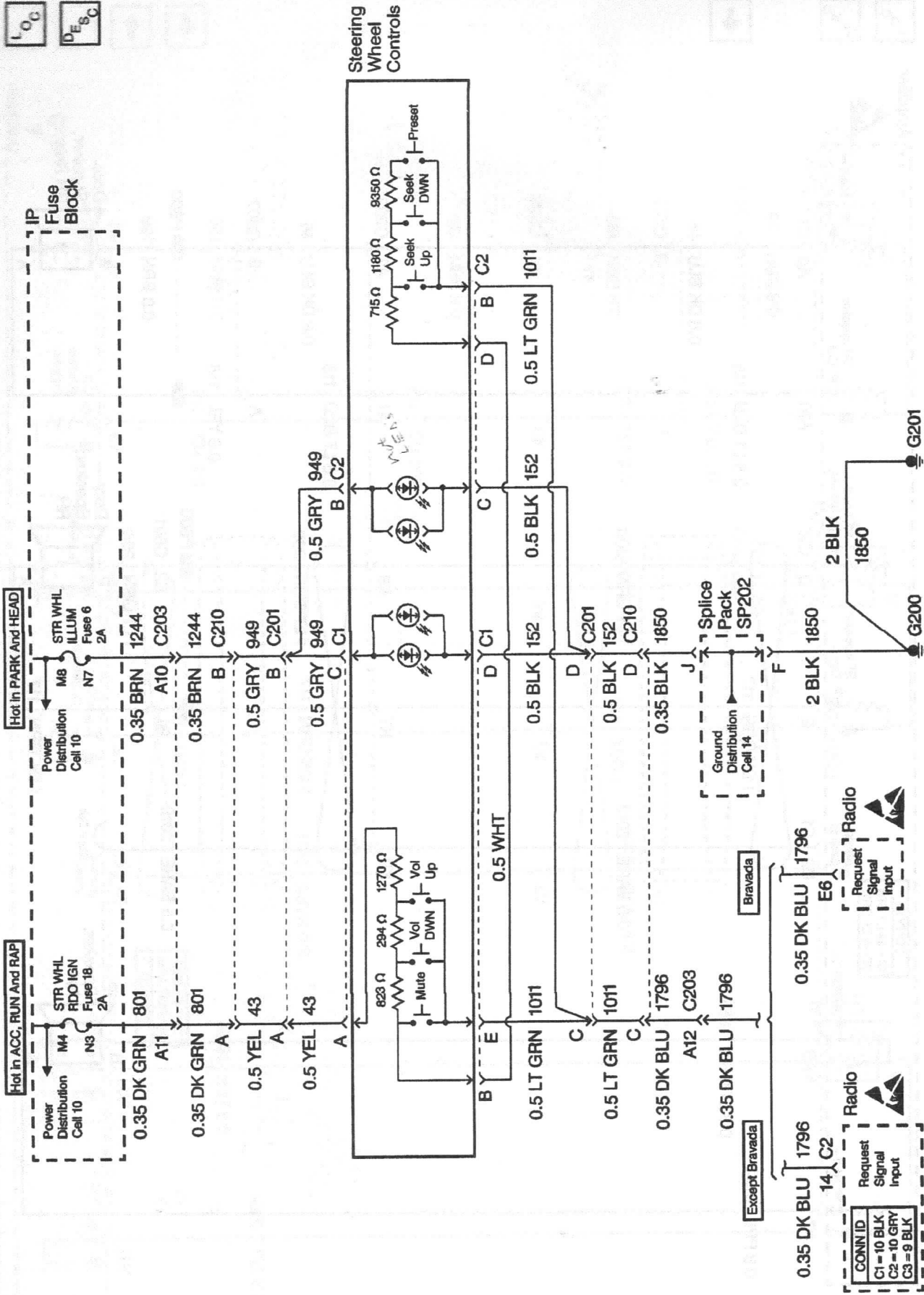

Radio/Audio System Schematics (Cell 150: Remote Audio Player (Chevy/GMC))

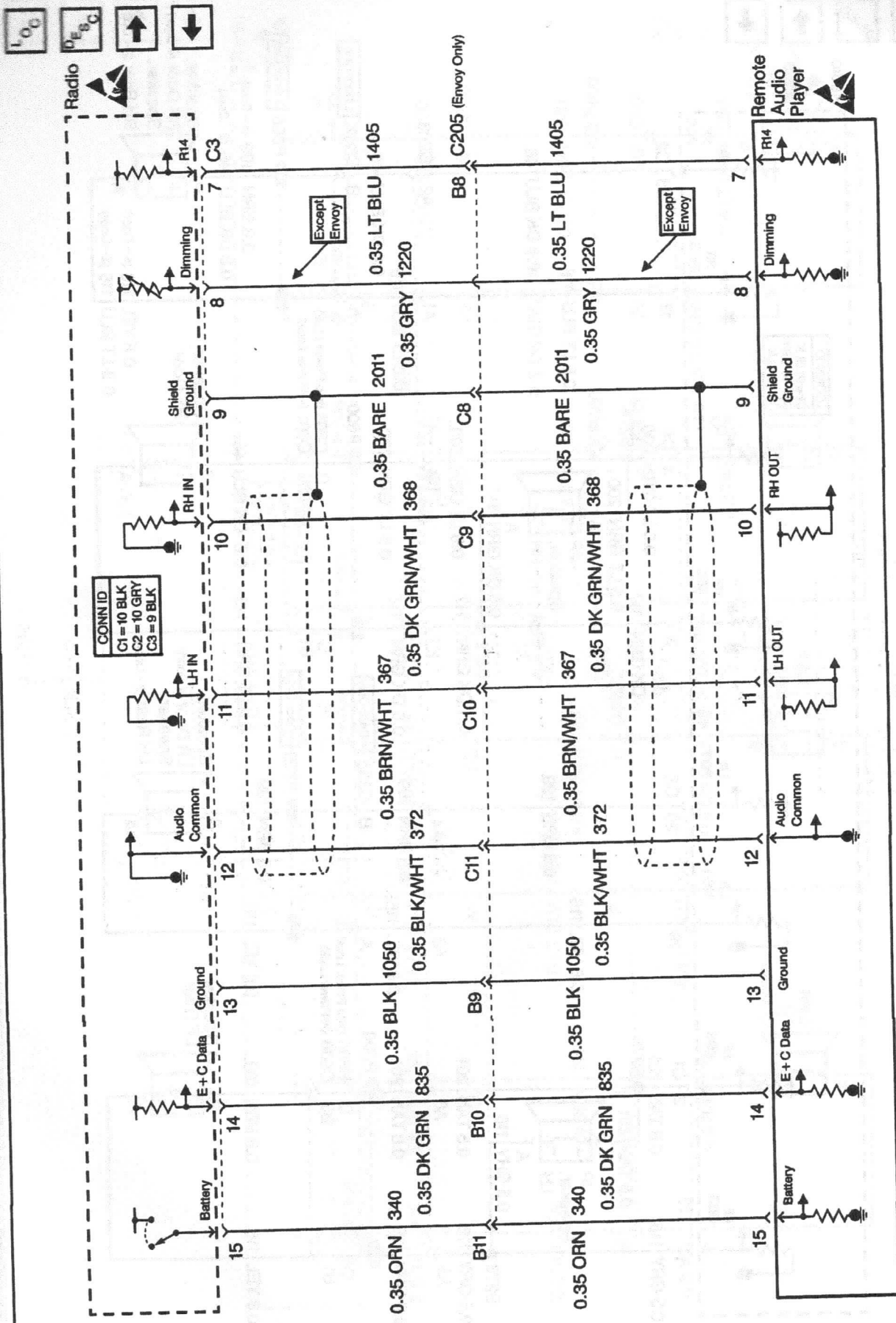

IP Speaker, RH (Uplevel)

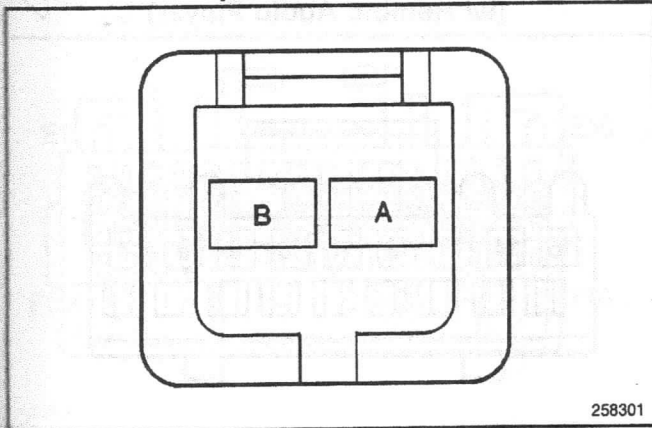

<b>Connector Part Information</b>		<ul style="list-style-type: none"> <li>• 12064778</li> <li>• 2-Way M Metri-Pack 150 Series (GRN)</li> </ul>	
<b>Pin</b>	<b>Wire Color</b>	<b>Circuit No.</b>	<b>Function</b>
A	PPL	117	Speaker Return - Right Front
B	LT GRN	200	Speaker Feed - Right Front

Radio (All Except Bravada) Connector C1

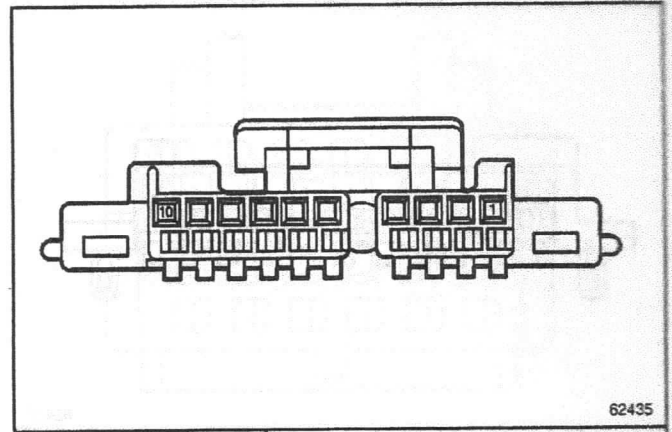

<b>Connector Part Information</b>		<ul style="list-style-type: none"> <li>• 12047531</li> <li>• 10-Way F Micro-Pack 100 Series (BLK)</li> </ul>	
<b>Pin</b>	<b>Wire Color</b>	<b>Circuit No.</b>	<b>Function</b>
1	GRY	118	Audio Signal - Left Front (w/o Amp)
1	TAN	511	Audio Signal - Left Front (w/ Amp)
2	TAN	201	Audio Signal Left - Front (w/o Amp)
2	ORN/BLK	1546	Audio Return - Front (w/ Amp)
3	DK GRN	117	Audio Signal - Right Front (w/o Amp)
3	LT GRN	512	Audio Signal - Right Front (w/ Amp)
4	LT GRN	200	Audio Signal Right - Front (w/o Amp)
4	BARE	1573	Drain Wire Return - Front Audio (w/ Amp)
5	BLK	1050	Ground
6	PPL/WHT	1382	LED Dimming Signal
7	GRY	1220	Fuse Output - Instrument Panel Lamps
8	—	—	Not Used (w/o Amp)
8	DK GRN	145	Switched Power Output - Amp Feed (w/ Amp)
9	DK GRN	1301	Fuse Output - Retained Accessory Power
10	ORN	340	Fuse Output - Battery - Type III Fuse

Radio (All Except Bravada) Connector C2

Radio (All Except Bravada) Connector C3  
(w/ Remote Audio Player)

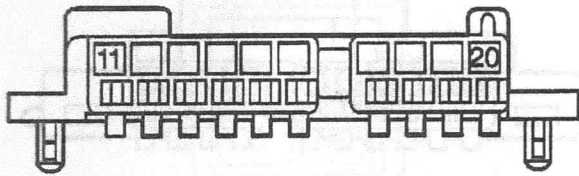

62477

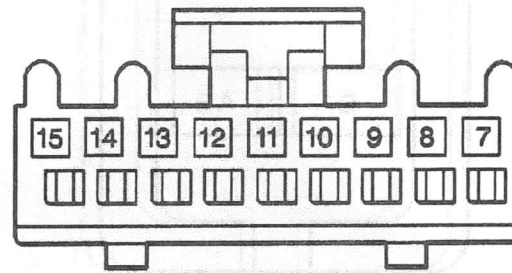

62467

Connector Part Information		<ul style="list-style-type: none"> <li>• 12065785</li> <li>• 10-Way F Micro-Pack 100 Series (GRY)</li> </ul>	
Pin	Wire Color	Circuit No.	Function
11	—	—	Not Used
12	PNK	314	Radio Signal - On (Envoy Only)
13	LT GRN	1011	Remote Radio Control Signal (Envoy Only)
14	—	—	Not Used (Pick-up)
14	DK BLU	1796	Radio Control Signal - Steering Column (Utility)
15	DK GRN	835	Diagnostic Signal - Entertainment and Comfort (Envoy Only)
16	DK GRN	389	Vehicle Speed Signal - 4000 Pulses Per Mile
17	LT BLU	115	Speaker Return - Right Rear (w/o Amp)
17	DK BLU	546	Audio Signal - Right Rear (w/ Amp)
18	DK BLU	46	Audio Signal Right - Rear - Low Level (w/o Amp)
18	DK GRN/ WHT	1547	Audio Return - Rear - Low Level (w/ Amp)
19	YEL	116	Speaker Return - Left Rear (w/o Amp)
19	BRN	599	Audio Signal - Left Rear - Low Level (w/ Amp)
20	BRN	199	Audio Signal - Left Rear (w/o Amp)
20	BARE	1574	Drain Wire Return - Rear Audio (w/ Amp)

Connector Part Information		<ul style="list-style-type: none"> <li>• 12064980</li> <li>• 9-Way F Micro-Pack 100 Series (BLK) 7</li> </ul>	
Pin	Wire Color	Circuit No.	Function
7	LT BLU	1405	Tape Player Signal - Remote - Audio Communication
8	GRY	1220	Dimming Signal (except Envoy)
9	BARE	701	Drain Wire Return
10	DK GRN/ WHT	368	Remote Radio Signal - Right Audio
11	BRN/WHT	367	Remote Radio Signal - Left Audio
12	BLK/WHT	372	Remote Radio Return - Audio
13	BLK	1050	Ground
14	DK GRN	835	Diagnostic Signal - Entertainment and Comfort
15	ORN	340	Fuse Output - Battery

↑  
Pin 7 or 14; Signal to Radio Control that AUX is in use?  
Pin 15: RAP RDO PWR

Radio w/ ATC CD (Bravada)

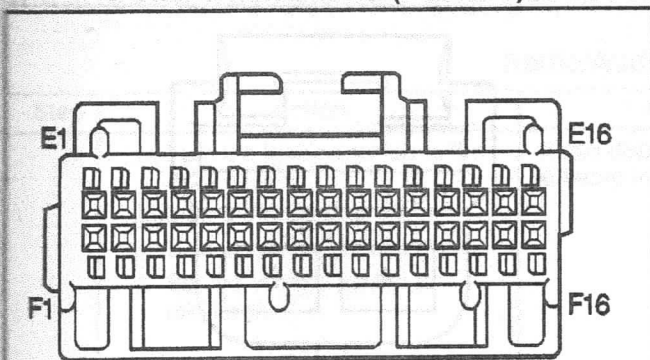

73222

Connector Part Information		<ul style="list-style-type: none"> <li>• 12110115</li> <li>• 32-Way F Micro-Pack 100 Series (BLU)</li> </ul>	
Pin	Wire Color	Circuit No.	Function
E1-E11	—	—	Not Used
E12	BRN	199	Speaker Feed - Left Rear
E13	YEL	116	Speaker Return - Left Rear
E14	DK GRN	117	Speaker Feed - Right Front
E15	LT GRN	200	Speaker Feed - Right Front
E16	BLK	1050	Ground
F1	ORN	340	Fuse Output - Battery - Type II Fuse
F2	DK GRN	1301	Fuse Output - Retained Accessory
F4	GRY	1220	Fuse Output - Instrument Panel Lamps - Type III Fuse
F5	PPL/WHT	1382	Led Dimming Signal
F6-F11	—	—	Not Used
F12	TAN	201	Speaker Feed - Left Front
F13	GRY	118	Speaker Return - Left Front
F14	LT BLU	115	Speaker Return - Right Rear
F15	DK BLU	46	Speaker Feed - Right Rear
F16	—	—	Not Used

Rear Seat Audio Control (Envoy Only)

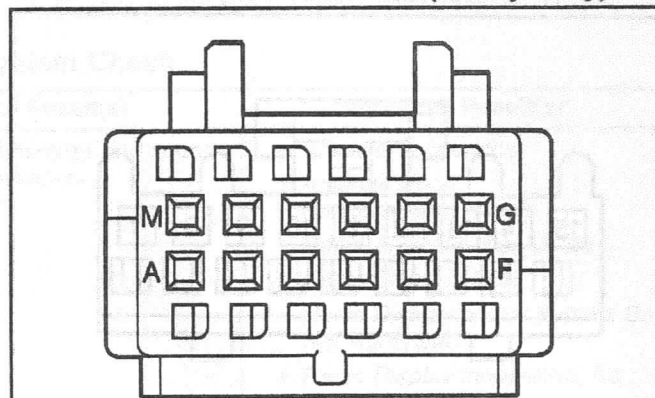

73151

Connector Part Information		<ul style="list-style-type: none"> <li>• 12064799</li> <li>• 12-Way F Micro-Pack 100 Series (BLK)</li> </ul>	
Pin	Wire Color	Circuit No.	Function
A	DK GRN	1301	Fuse Output - Retained Accessory Power
B	BRN	2409	Fuse Output - Retained Accessory Power
C	BLK	1050	Ground
D	PNK	314	Radio Signal - On
E-H	—	—	Not Used
J	DK GRN/WHT	368	Remote Radio Signal - Right Audio
K	BLK/WHT	372	Remote Radio Return - Audio
L	BRN/WHT	367	Remote Radio Signal - Left Audio
M	LT GRN	1011	Remote Radio Control Signal