

Fig. 20: Ground Distribution Circuit (1 of 3)

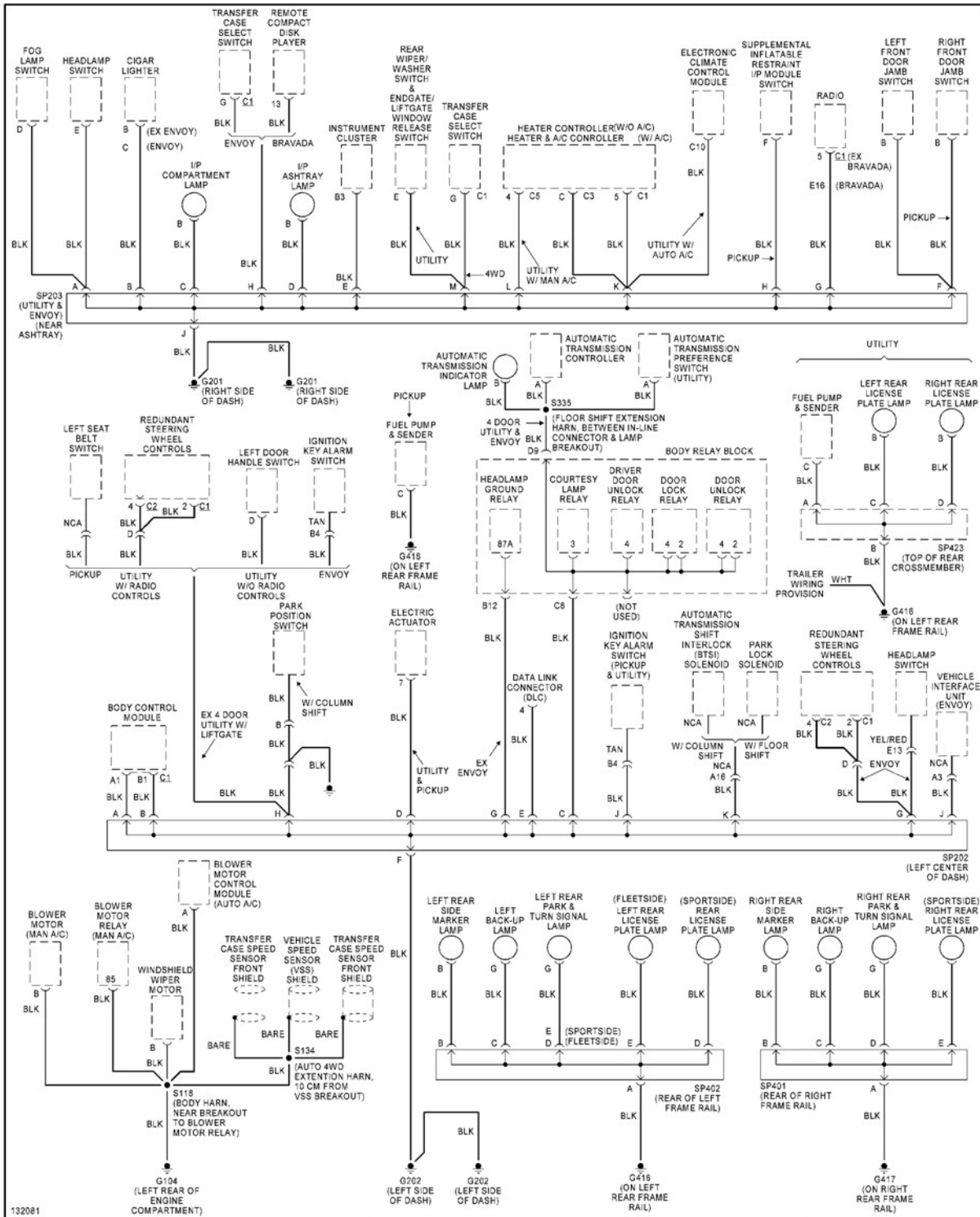

Fig. 21: Ground Distribution Circuit (2 of 3)

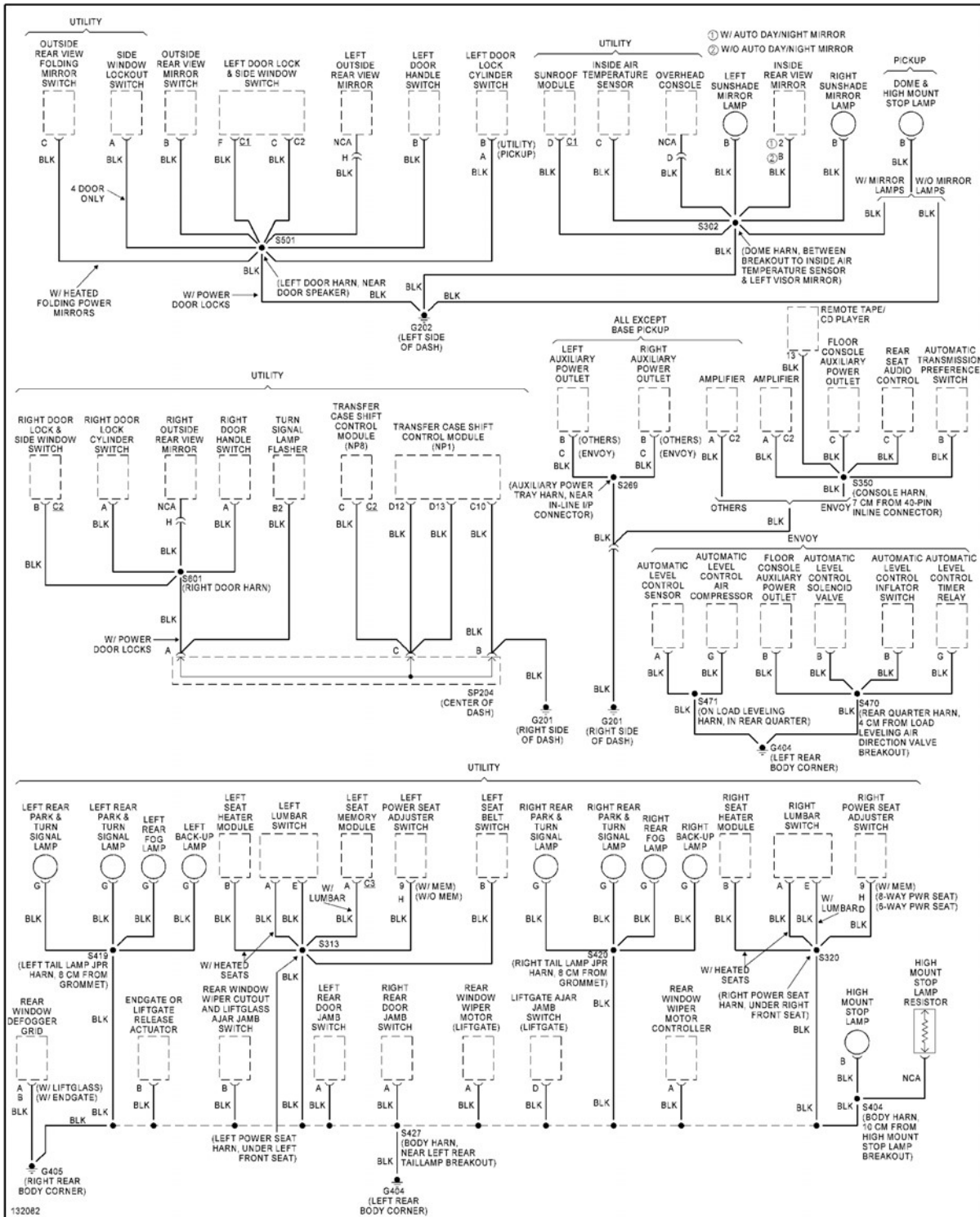

Fig. 22: Ground Distribution Circuit (3 of 3)

HEADLIGHTS