

Body Control Module Replacement

[Removal Procedure](#)

Important

The ignition switch should be in the OFF position when connecting or disconnecting the connectors to the BCM. Always disconnect the Brown BCM connector FIRST and connect the Brown BCM connector LAST. The BCM can set DTC(s) with the ignition switch in the OFF position.

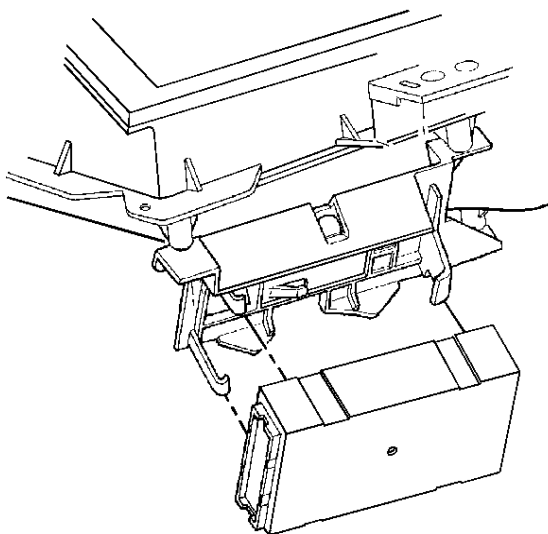

1. Remove the left instrument panel sound insulator from the vehicle. Refer to [Closeout/Insulator Panel Replacement - Left](#) in Instrument Panel, Gauges and Console.
2. Remove the center instrument panel sound insulator from the vehicle. Refer to [Closeout/Insulator Panel Replacement - Center](#) in Instrument Panel, Gauges and Console.
3. Disconnect the electrical connectors from the body control module.
4. Bend the 2 snap retainers back slightly and pull the body control module from the bracket at an angle.

[Installation Procedure](#)

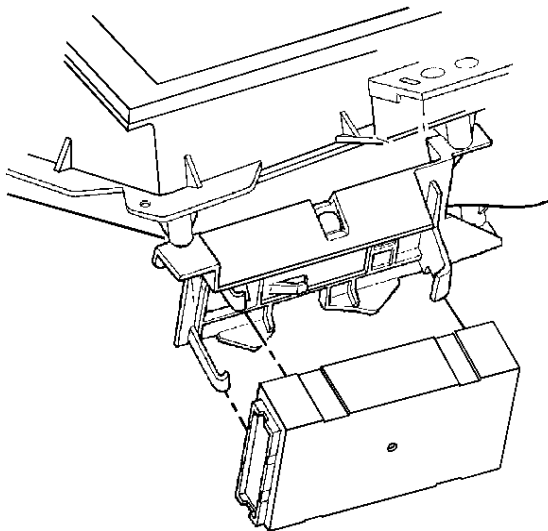

1. Install the body control module to the bracket at an angle under the wide hook retainer, with the label facing away from the bracket.
2. Apply pressure on the left side of the body control module in order to move the module toward the mounting bracket base. Snap the module into place.
3. Ensure that the module is fully seated. Ensure that both snap retainers are holding the module.
4. Connect the electrical connectors to the body control module. Be sure to connect the brown connector last.
5. Install the center instrument panel sound insulator to the vehicle. Refer to [Closeout/Insulator Panel Replacement - Center](#) in Instrument Panel, Gauges and Console.
6. Install the left instrument panel sound insulator to the vehicle. Refer to [Closeout/Insulator Panel Replacement - Left](#) in Instrument Panel, Gauges and Console.
7. Use the following components in order to program the body control module with the proper calibrations:
 - The Techline Terminal
 - The scan tool
8. Perform the BCM Programming. Refer to [Body Control Module \(BCM\) Programming/RPO Configuration](#).
9. Clear the diagnostic trouble codes (DTCs).

<- Back

Forward ->

Document ID# 555186
2001 Chevrolet/Geo Blazer - 4WD

Print