

## Inner Shaft Seal and Bearing Replacement

### Removal Procedure

#### Tools Required

- J 23907 Slide Hammer
- J 29369-1 Universal Bearing Remover

1. Remove the inner axle shaft. Refer to *Inner Axle Housing Shaft and Housing Replacement (Except Bravada)* or *Inner Axle Housing Shaft and Housing Replacement (Bravada)*.
2. Hold the inner axle shaft housing in a vise by the carrier mounting flange.
3. Remove the inner axle shaft seal using a suitable seal remover.
4. Remove the inner axle shaft bearing using the J 29369-1 and the J 23907.

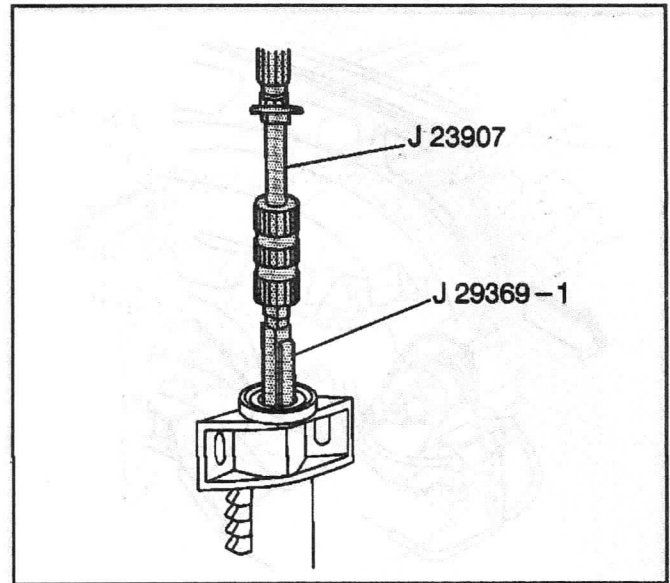

9105

### Installation Procedure

#### Tools Required

- J 8092 Driver Handle
- J 23911 Seal Installer
- J 42211 Bearing Installer

1. Place the inner axle shaft housing to carrier flange flat on a level surface.
2. Install the inner axle shaft bearing using the J 42211 and the J 8092.  
The bearing is installed to the proper depth when the tool is flush with the tube end.
3. Lubricate the bearing using axle lubricant. Refer to *Fluid and Lubricant Recommendations* in Maintenance and Lubrication.

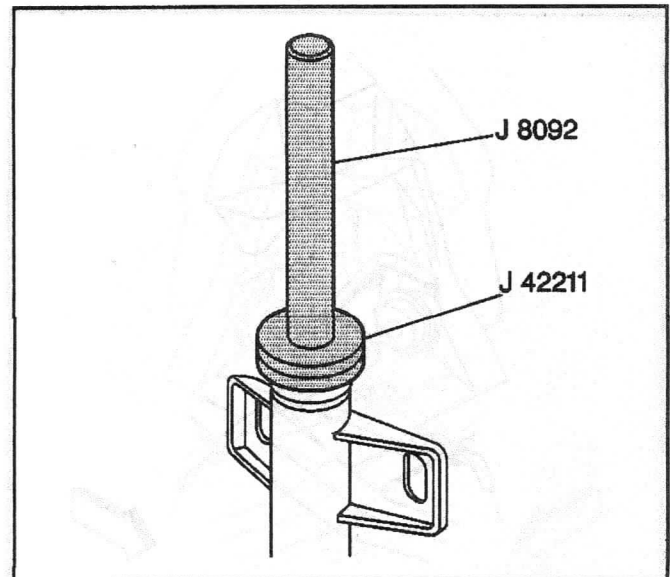

524680

4. Install the inner axle shaft seal with the J 23911. Drive in the seal until the seal flange is flush with the tube end.
5. Install the inner axle shaft. Refer to *Inner Axle Housing Shaft and Housing Replacement (Except Bravada)* or *Inner Axle Housing Shaft and Housing Replacement (Bravada)*.

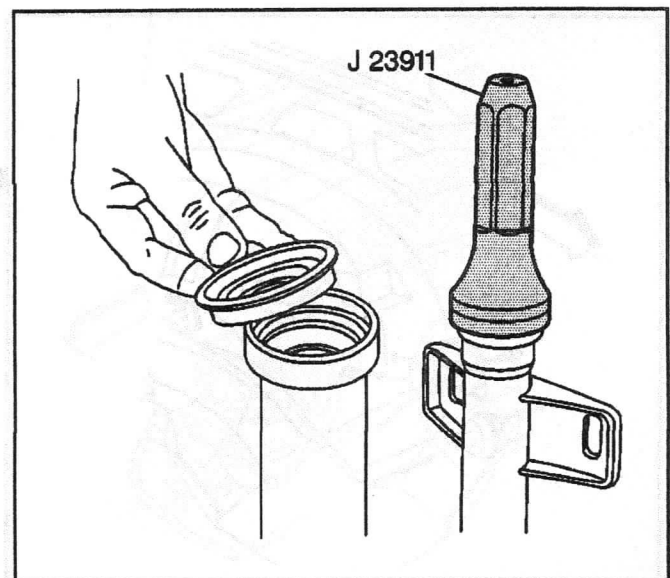

321864