

# Front Drive Axle

## Specifications

### Fastener Tightening Specifications

Application	Specification	
	Metric	English
Carrier Assembly to Frame Mounting Bolts	103 N·m	76 lb ft
Carrier Halves Assembly Bolts	50 N·m	37 lb ft
Differential Carrier Shield Bolts	25 N·m	18 lb ft
Differential Carrier Shield Bracket Bolt	103 N·m	76 lb ft
Drain Plug	33 N·m	24 lb ft
Fill Plug	33 N·m	24 lb ft
Left Side Cover to Carrier Bolts	25 N·m	18 lb ft
Pinion Shaft Lock Bolt	3.4 N·m	25 lb in
Right Side Axle Housing to Carrier Bolts	48 N·m	36 lb ft
Right Side Axle Housing to Frame Bracket Nuts	98 N·m	72 lb ft
Ring Gear to Case Mounting Bolts	80 N·m	59 lb ft
Shift Cable Coupling Nut	10 N·m	90 lb in
Shaft Cable Hold down Bolt	17 N·m	13 lb ft
Shift Cable Housing to Carrier Bolts	48 N·m	36 lb ft
Shaft Indicator Switch	5 N·m	44 lb in
Side Bearing Adjuster Sleeve Lock Tab Bolts	8 N·m	71 lb in
Vacuum Actuator Bolts	1.4 N·m	13 lb in

### Lubrication Specifications

Application	Specification	
	Metric	English
Front Axle	1.2 L	2.6 pts
Type Recommended	SAE 80-W-90 GL-5 GM P/N 1052271	

### Pinion Preload and Backlash

Application	Specification	
	Metric	English
Backlash	0.08-0.25 mm	0.003-0.010 inch
Backlash (Preferred)	0.13-0.18 mm	0.005-0.007 inch
Pinion Preload	1.7-2.8 N·m	15-25 lb in

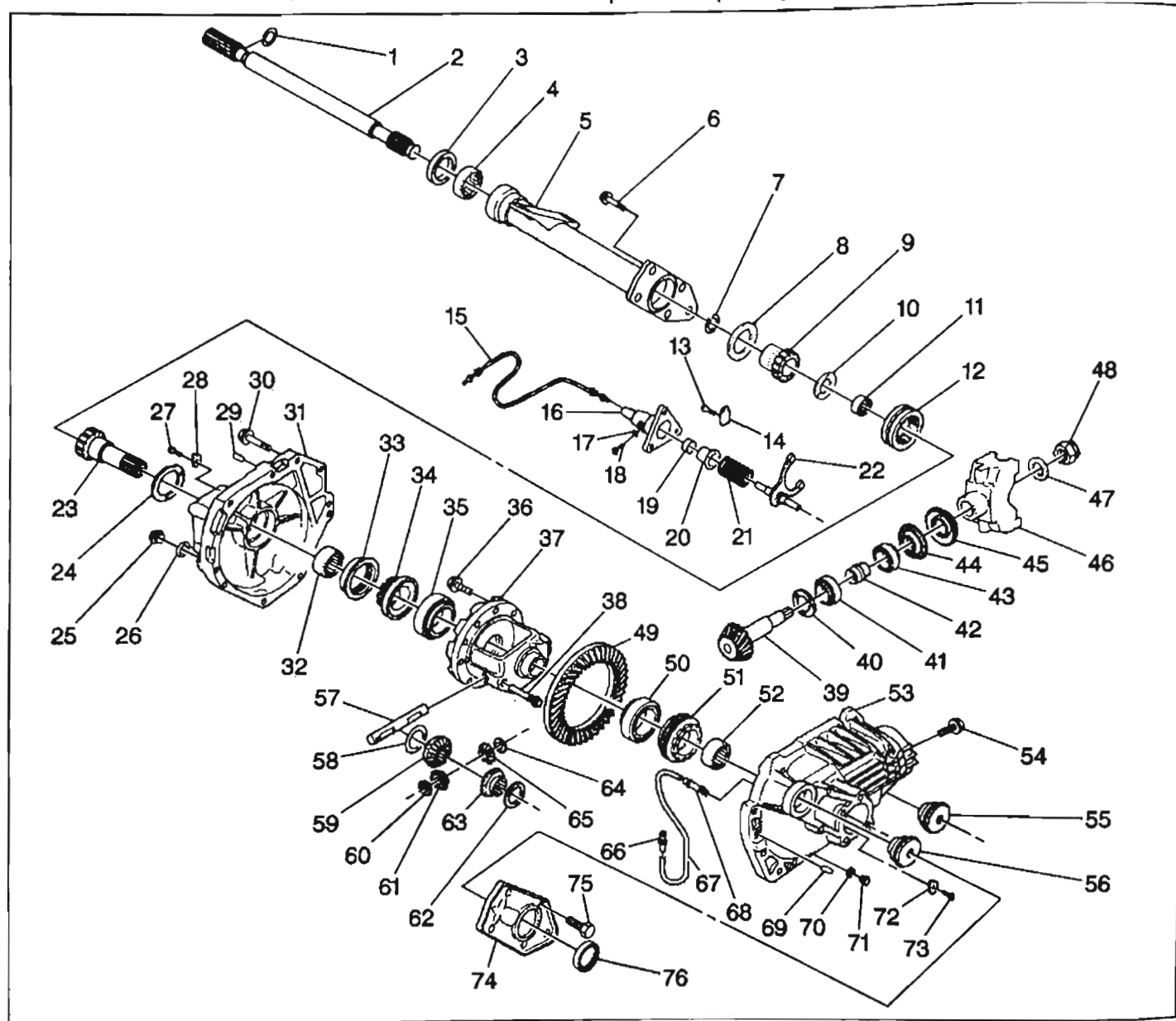
### GM SPO Group Numbers

Application	GM SPO Group Number
Front Axle, Axle Kit, Shaft and Shaft Kit	6.055
Front Axle Bearing, Bolt, Cover, Deflector, Nut, Ring, Seal, Shim, Sleeve, Spacer and Washer	6.056
Front Drive Axle Shifter/Lock Actuator, Clip, Connector, Fork, Ring, Rivet, Shaft, Spring and Washer	6.058

# Component Locator

## Front Axle Components

### 4WD Front Drive Axle Components (Except Bravada)



370897

### Legend

- |                    |                   |
|--------------------|-------------------|
| (1) Retaining Ring | (13) Bolt         |
| (2) Axle Shaft     | (14) Lock         |
| (3) Seal           | (15) Cable        |
| (4) Bearing        | (16) Housing      |
| (5) Housing        | (17) Seal         |
| (6) Bolt           | (18) Switch       |
| (7) Retaining Ring | (19) Outer Spring |
| (8) Washer         | (20) Seal         |
| (9) Clutch Gear    | (21) Inner Spring |
| (10) Washer        | (22) Fork         |
| (11) Bearing       | (23) Clutch Shaft |
| (12) Clutch Sleeve |                   |

---

(24) Washer	(51) Insert
(25) Drain Plug	(52) Bearing
(26) Drain Plug Gasket	(53) Carrier
(27) Nut	(54) Bolt
(28) Nut Lock	(55) Bushing
(29) Pin	(56) Bushing
(30) Bolt	(57) Shaft
(31) Carrier	(58) Washer
(32) Bearing	(59) Side Gear
(33) Adjuster	(60) Washer
(34) Sleeve	(61) Pinion Gear
(35) Bearing	(62) Washer
(36) Bolt	(63) Side Gear
(37) Case	(64) Washer
(38) Bolt	(65) Pinion Gear
(39) Pinion Gear	(66) Vent
(40) Shim	(67) Hose
(41) Bearing	(68) Hose End
(42) Spacer	(69) Pin
(43) Bearing	(70) Drain Plug Gasket
(44) Seal	(71) Drain Plug
(45) Deflector	(72) Nut Lock
(46) Yoke	(73) Nut
(47) Washer	(74) Cover
(48) Nut	(75) Bolt
(49) Ring Gear	(76) Seal
(50) Bearing	

---



(49) Vent Hose	(56) Cover
(50) Fitting	(57) Retaining Ring
(51) Pin	(58) Seal
(52) Washer	(59) Bolt
(53) Plug	(60) Axle Shaft
(54) Lock	(61) Retaining Ring
(55) Bolt	

## Diagnostic Information and Procedures

### Front Axle Noise Source Determination

#### Road Noise

Some road surfaces cause noise that may be mistaken for tire or axle noise. Road noise is usually the same while driving or coasting. Driving on a smooth surface helps determine the cause of the noise.

Perform the following maintenance/diagnostic checks:

- Check the tires for irregular wear.
- Check the tire pressure.
- Check the front axle lubricant level.
- Drive the vehicle to warm up the front axle.
- Drive the vehicle at various speeds in drive, float, coast, and while cornering.

#### Tire Noise

Tire noise continues with lower tone as the vehicle slows down. Tire noise may easily be mistaken for axle noise. Tire noise changes with varying road surfaces. Axle noise does not change, although, it usually stops when coasting at speeds under 48 km/h (30 mph). Temporarily inflating all the tires to 345 kPa (50 psi) pressure for test purposes only will materially alter noise caused by tires, but will not affect noise caused by the axle.

Perform the following maintenance/diagnostic checks:

- Change the tire pressure to minimize noises.
- Drive over different road surfaces.
- Drive on smooth blacktop to minimize tire noise.
- Cross switch the tires, if necessary.
- Remember that snow tire treads and tire studs cause added noise.

### Engine and Transmission Noises

In order to determine which unit is at fault, take note of approximate vehicle speeds and conditions under which the noise is most pronounced. Stop the vehicle in a quiet place to stop interfering noises. With the transmission in neutral, run the engine slowly throughout the range corresponding to the vehicle speed at which the noise was most pronounced. If a similar noise is produced, the noise is caused by the engine or transmission and not the axle.

Perform the following diagnostic checks:

1. Drive slightly above the speed where the noise occurs. Place the transmission in neutral.
2. Let the engine speed drop to idle.
3. Stop the vehicle.
4. Run the engine at various speeds.

### Wheel Bearing Noise

Raise the vehicle on a twin post hoist. Spin the wheels by hand. Listen for a knock or a click about every two revolutions of the wheel. The bearing rollers do not travel at the same speed as the axle and the wheel.

Perform the following diagnostic checks:

1. Drive the vehicle at low speed on a smooth road.
2. Turn to the left and turn to the right. The noise should change with the cornering loads.
3. Jack up the wheels in order to verify roughness at the wheels.

### Gear Noise

There are two basic types of gear noise. The first type is produced by broken, bent, or forcibly damaged gear teeth which is usually quite audible over the entire speed range, and presents no difficulty in diagnosis. Hypoid gear tooth scoring is one example that generally results from the following conditions:

- Insufficient lubricant
- Improper lubricant
- Improper break-in
- Insufficient gear backlash
- Improper ring and pinion alignment
- Loss of drive pinion nut torque

This scoring will progressively lead to complete erosion of the gear teeth or gear teeth pitting and then eventual fracture if the initial scoring is not corrected. Another cause of hypoid gear fracture is extended overloading of the gear set. This will produce fatigue fracture, or shock loading, which will result in sudden failure.

The second type of gear noise pertains to the mesh pattern of the gear teeth. This form of abnormal gear noise can be recognized because it produces a cycling pitch (whine) and will be very pronounced. It tends to peak in a narrow speed range, appearing under drive, float, or coast conditions and will remain constant in pitch. Bearing noise will vary in pitch with vehicle speeds.

- Rough running or a whine noise should increase with speed.
- Noise pitch should be higher than differential noise.
- Front pinion bearing noise may be louder on deceleration.
- Rear pinion bearing noise may be louder on acceleration.

Perform the following diagnostic check:

- Road test the vehicle on a smooth road in order to minimize tire noise.
- Road test the vehicle at various speeds in drive, float, and coast.

### Noise Diagnosis

**Notice:** Do not attempt to operate the vehicle without supporting the lower control arm. When the wheel drive shaft CV joints are at a high angle, extra vibrations can occur and may damage the seals and the joints.

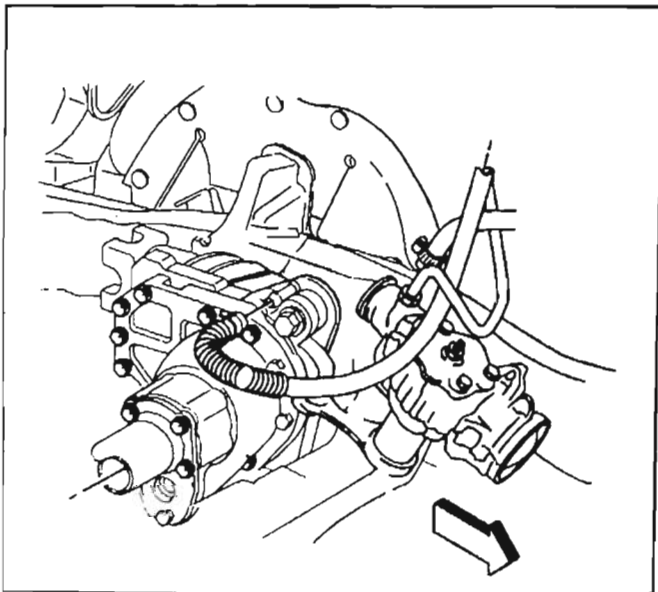
Any gear-driven unit produces a certain amount of noise that is normal and cannot be eliminated by conventional repairs or adjustments. Slight noise that is heard only at a certain speed or under unusual or remote conditions is acceptable. For example, a noise that tends to reach a peak at speeds from 60 to 100 km/h (40 to 60 mph) depending on road conditions, load conditions, gear ratio, or tire size does not indicate trouble in the axle assembly.

When an axle is suspected of being noisy, check to determine whether the noise originates in the tires, road surface, wheel bearings, engine, transmission, propeller shaft, or axle assembly. Raise the tire pressure to eliminate tire noise (although this will not silence the tread noise of mud and snow tires). Listening for the noise at varying speeds and road surfaces, on drive, float, and coast conditions will help to locate the source of the noise.

### Repair Instructions

#### Vent Hose Replacement

When replacing the hose, ensure that the hose is routed correctly, free of kinks, and clear of sharp components. Ensure the vent is not plugged.

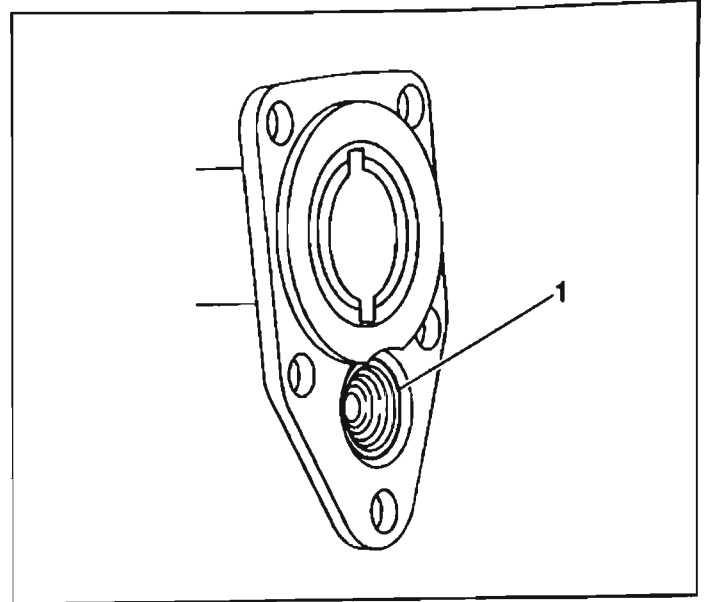


343771

## Shift Cable Housing Seal Replacement

### Removal Procedure

1. Remove the inner axle shaft. Refer to *Inner Axle Housing Shaft and Housing Replacement (Except Bravada)* or *Inner Axle Housing Shaft and Housing Replacement (Bravada)*.
2. Remove the shift cable housing seal (1). Drive the seal out of the axle housing to carrier flange using a punch.



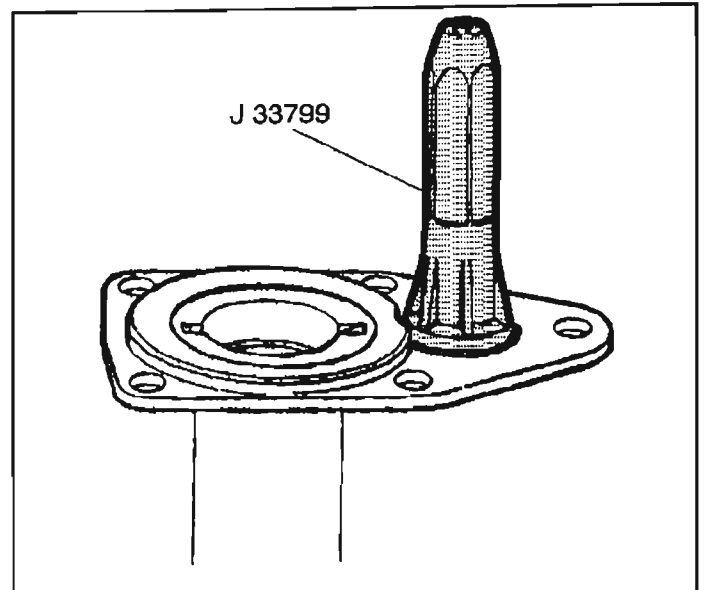
534487

### Installation Procedure

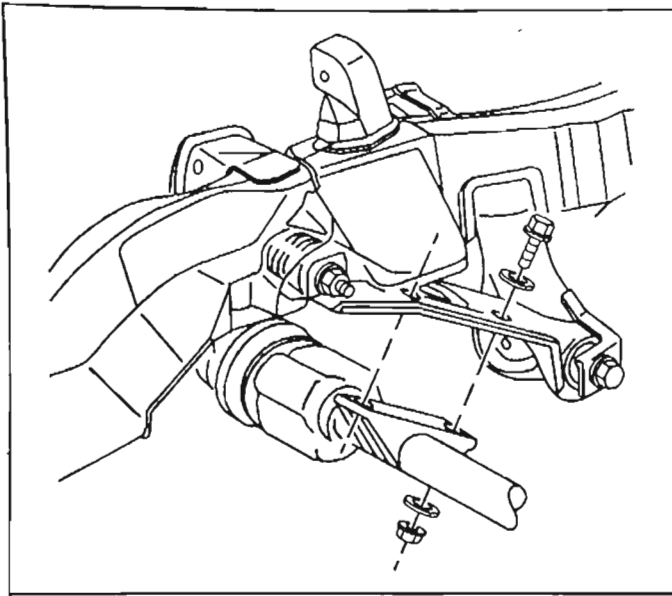
#### Tools Required

J 33799 Shift Cable Housing Seal Installer

1. Install the shift cable housing seal using the J 33799.
2. Install the inner axle shaft. Refer to *Inner Axle Housing Shaft and Housing Replacement (Except Bravada)* or *Inner Axle Housing Shaft and Housing Replacement (Bravada)*.



7796



6834

## Inner Axle Housing Shaft and Housing Replacement (Except Bravada)

### Removal Procedure

**Important:** Observe and accurately reference mark the positions of all driveline components relative to the propeller shaft prior to disassembly. These components include the propeller shafts, drive axles, pinion flange, inner axle shafts, etc. Reassemble all components in the exact relationship the components had to one another prior to disassembly. Follow the specifications, torque values and any measurement made prior to disassembly in order to maintain the factory system balance of the driveline components. System balance provides a smoother running driveline operation.

1. Raise the vehicle. Refer to *Lifting and Jacking the Vehicle* in General Information.
2. Position a drain pan under the inner axle shaft housing.
3. Remove the right side wheel drive shaft. Refer to *Wheel Drive Shafts Replacement* in Wheel Drive Shafts.
4. Remove the five axle shaft housing to carrier bolts.
5. Remove the shift cable housing assembly from the carrier.
6. Remove the two axle shaft housing to frame bracket bolts, nuts and washers.

**Important:** Do not allow the following components to fall out of the carrier assembly or become damaged:

- The thrust washers
  - The clutch gear, which may remain attached to the inner axle shaft.
  - The clutch sleeve
  - The clutch shaft
7. Remove the inner axle shaft and housing assembly from the carrier.
  8. Remove the inner axle shaft from the housing.
    - 8.1. Hold the housing in a vise by the carrier mounting flange.
    - 8.2. Tap out the shaft using a soft mallet.
    - 8.3. Separate the inner axle shaft and the clutch gear, if necessary.
  9. Inspect the following components for wear:
    - The inner axle shaft pilot and the clutch shaft pilot bearing
    - The inner axle shaft seal and bearing
    - The shift cable housing seal
  10. Replace as necessary. Refer to the correct procedure:
    - *Clutch Shaft Bearing Replacement*
    - *Inner Shaft Seal and Bearing Replacement*
    - *Shift Cable Housing Seal Replacement*
  11. Clean the sealing surfaces of the inner axle shaft housing and the carrier with a chlorinated solvent.

## Installation Procedure

### Tools Required

J 33798 Hub Engagement Tool

1. Apply a bead of sealer (GM P/N 12345739 or equivalent) to the carrier sealing surface.
2. Install the inner axle shaft into the housing.
3. Ensure that the following components are in place in the carrier assembly:
  - The thrust washers
  - The clutch shaft
  - The clutch sleeve
  - The clutch gear
4. Install the clutch gear thrust washer to the housing as shown. Use grease in order to hold the washer in place.
5. Install the axle shaft and housing assembly to the carrier.
6. Install the axle shaft housing to carrier bolt at the 1 o'clock position. Tighten the bolt finger tight.
7. Position the shift cable housing on the axle housing to carrier flange.

**Notice:** Refer to *Fastener Notice* in Cautions and Notices.

8. Pull the axle shaft and housing assembly down in order to install the remaining bolts.

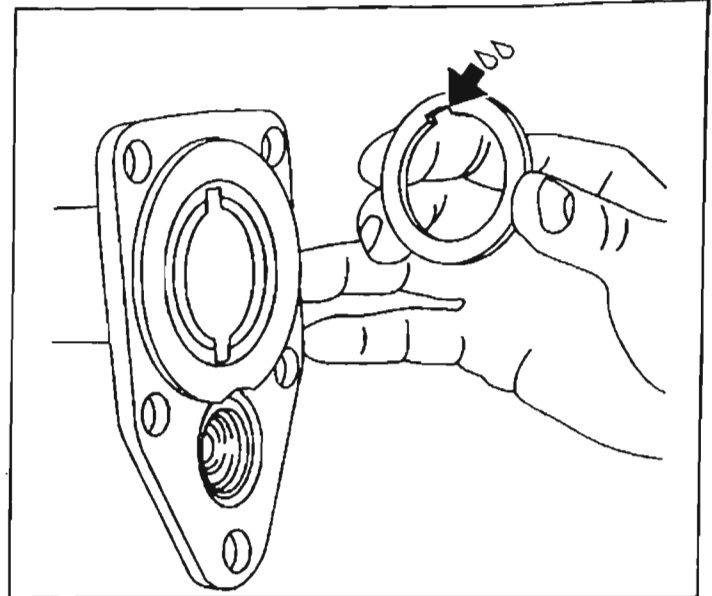
### Tighten

Tighten the five bolts to 48 N·m (36 lb ft).

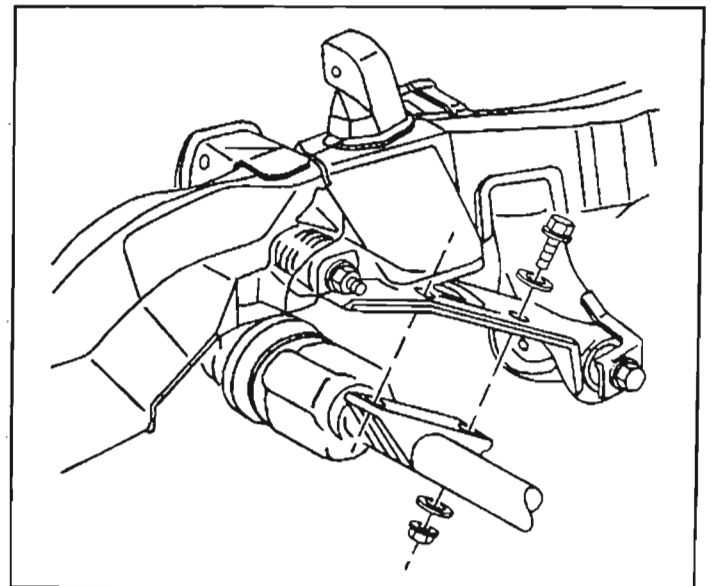
9. Install the two axle shaft housing to frame bracket bolts, nuts and washers.

### Tighten

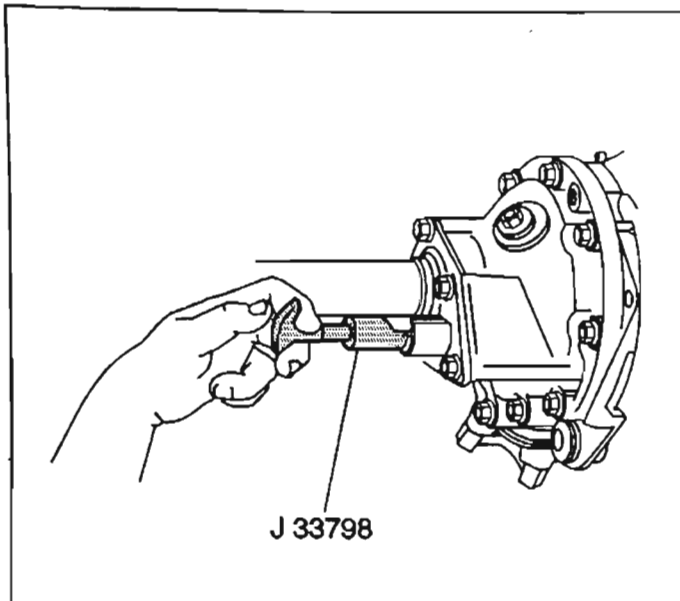
Tighten the nuts to 98 N·m (72 lb ft).



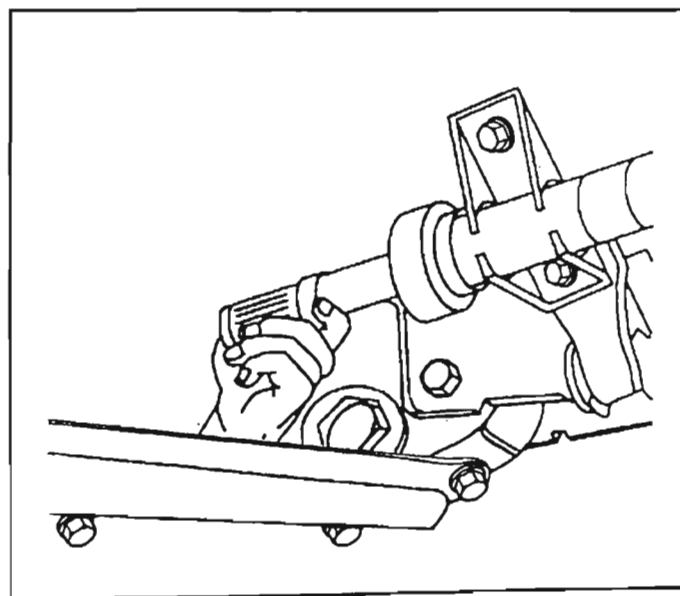
7797



5834



382657



161377

10. Inspect the operation of the shift mechanism. Use *J 33798*. Insert the tool into the shift fork. Inspect for rotation of the axle shaft.
11. Install the shift cable and indicator assembly to the shift cable housing.
12. Install the right side wheel drive axle. Refer to *Wheel Drive Shafts Replacement* in *Wheel Drive Shafts*.
13. Inspect the axle lubricant level and add as needed. Use the proper fluid. Refer to *Lubrication Specifications*.
14. Lower the vehicle.

### Inner Axle Housing Shaft and Housing Replacement (Bravada)

#### Removal Procedure

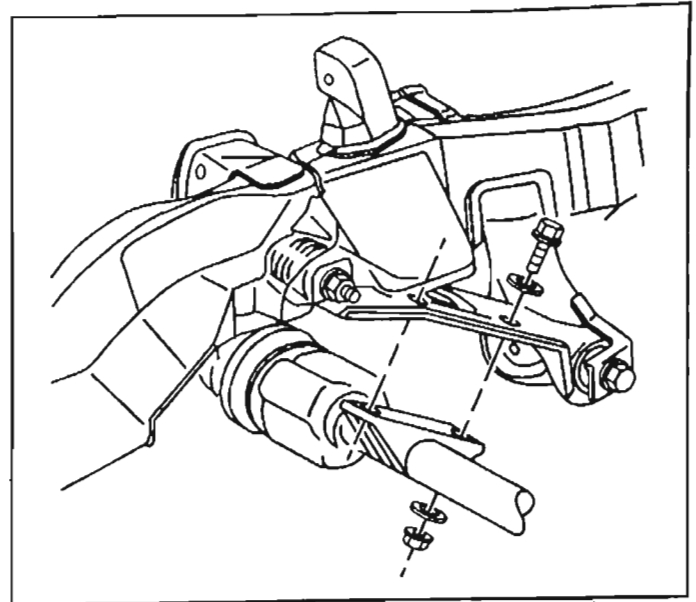
**Important:** Observe and accurately reference mark the positions of all driveline components relative to the propeller shaft prior to disassembly. These components include the propeller shafts, drive axles, pinion flange, inner axle shafts, etc. Reassemble all components in the exact relationship the components had to one another prior to disassembly. Follow the specifications, torque values and any measurement made prior to disassembly in order to maintain the factory system balance of the driveline components. System balance provides a smoother running driveline operation.

1. Raise the vehicle. Refer to *Lifting and Jacking the Vehicle* in *General Information*.
2. Position a drain pan under the inner axle shaft housing.
3. Remove the right wheel drive shaft. Refer to *Wheel Drive Shafts Replacement* in *Wheel Drive Shafts*.

**Important:** Be careful not to damage the seal surface when pulling the splined shaft through the seal.

4. Remove the right inner axle shaft from the housing.
  - 4.1. Protect the end of the inner axle shaft housing and the seal with a shop towel.
  - 4.2. Insert a bent screwdriver into the inner axle shaft retaining ring slot.
  - 4.3. Pry the screwdriver against the shop towel in order to disengage the inner axle shaft from the side gear.

5. Remove the two inner axle shaft housing to frame bracket bolts, nuts and washers.
6. Remove the five inner axle shaft housing to carrier bolts.
7. Remove the inner axle shaft housing.
8. Inspect the seal and bearing. Replace as necessary. Refer to *Inner Shaft Seal and Bearing Replacement*.
9. Clean the sealing surfaces of the inner axle shaft housing and the carrier with a chlorinated solvent.



6834

### Installation Procedure

**Important:** Reassemble all components in the exact relationship the components had to one another prior to disassembly. Follow the specifications, torque values and any measurement made prior to disassembly in order to maintain the factory system balance of the driveline components. System balance provides a smoother running driveline operation.

1. Apply a bead of sealer GM P/N 12345739 or the equivalent to the carrier sealing surface.
2. Install the inner axle shaft and the housing assembly.

**Notice:** Refer to *Fastener Notice* in Cautions and Notices.

3. Install the five inner axle shaft housing to the carrier assembly bolts.

#### Tighten

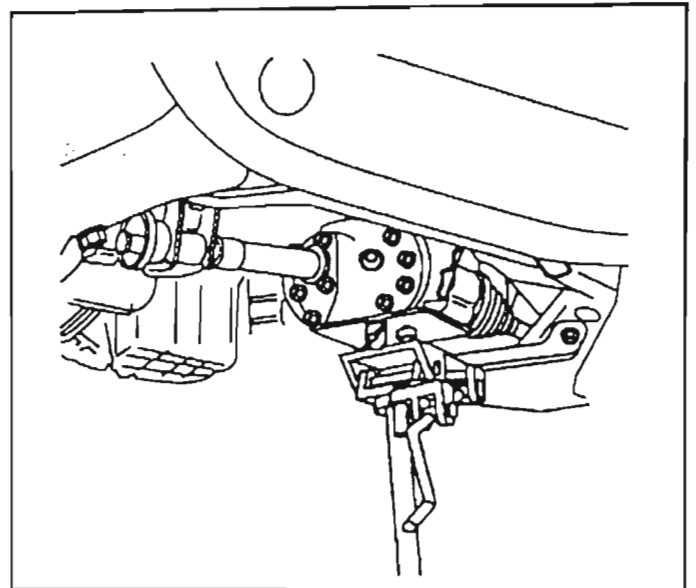
Tighten the bolts to 48 N·m (36 lb ft).

4. Install the inner axle shaft housing to frame bracket bolts, nuts and washers.

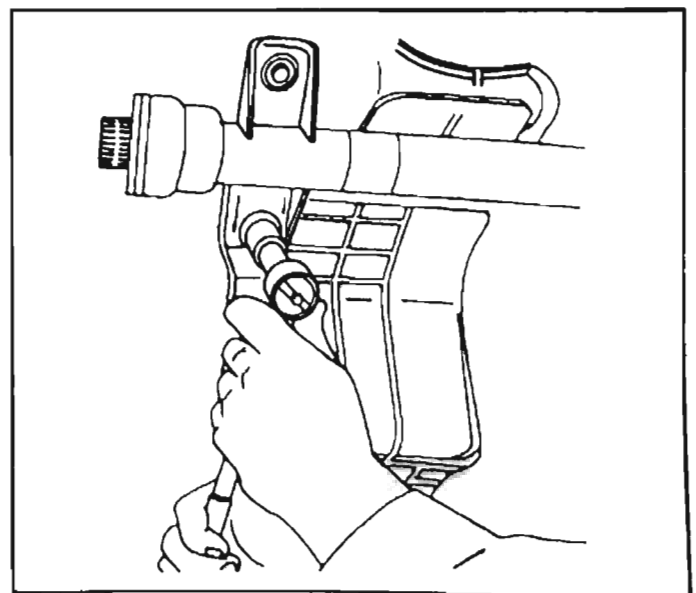
#### Tighten

Tighten the nuts to 98 N·m (72 lb ft).

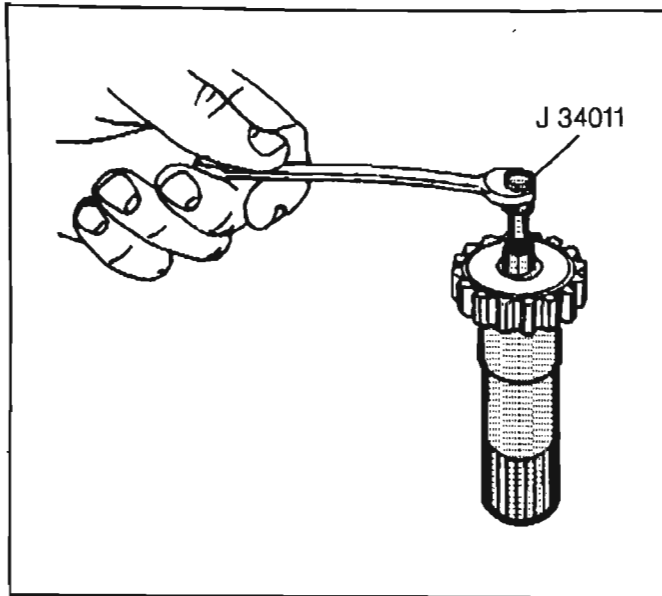
5. Install the right wheel drive shaft. Refer to *Wheel Drive Shafts Replacement* in *Wheel Drive Shafts*.
6. Inspect the axle lubricant level and add as needed. Use the proper fluid. Refer to *Lubrication Specifications*.
7. Lower the vehicle.



161386



161379



9106

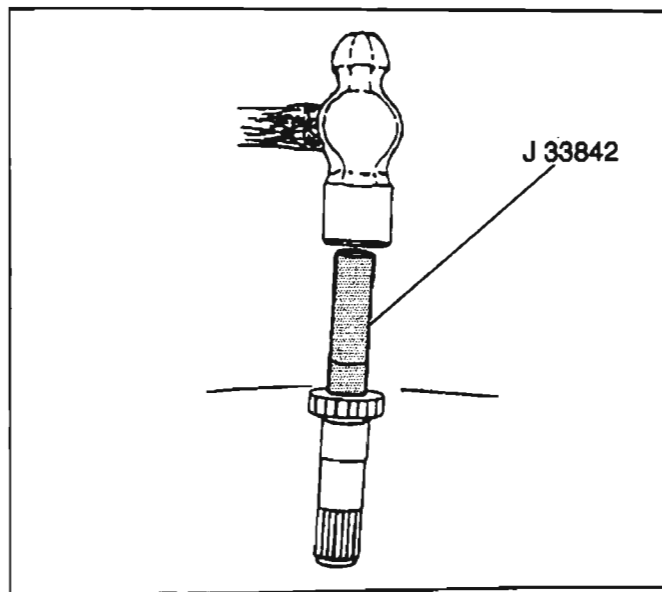
## Clutch Shaft Bearing Replacement

### Removal Procedure

#### Tools Required

*J 34011* Pilot Bearing Remover

1. Remove the inner axle shaft and housing assembly. Refer to *Inner Axle Housing Shaft and Housing Replacement (Except Bravada)*.
2. Remove the clutch shaft from the carrier.
3. Remove the clutch shaft pilot bearing with *J 34011*.



7796

### Installation Procedure

#### Tools Required

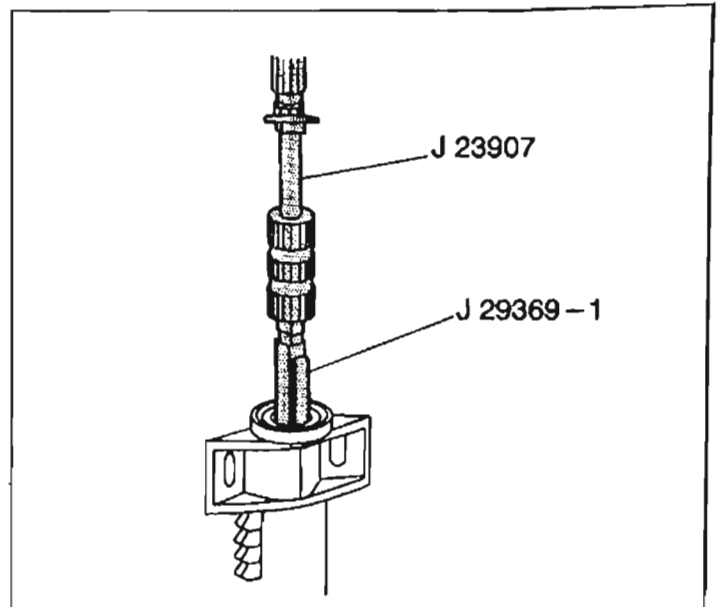
*J 33842* Pilot Bearing Installer

1. Install the clutch shaft pilot bearing using *J 33842*. Lubricate the bearing with axle lubricant, as specified in *Fluid and Lubricant Recommendations* in Maintenance and Lubrication.
2. Install the clutch shaft to the carrier.
3. Install the inner axle shaft and housing assembly. Refer to *Inner Axle Housing Shaft and Housing Replacement (Except Bravada)*.

## Inner Shaft Seal and Bearing Replacement Removal Procedure

### Tools Required

- J 23907 Slide Hammer
  - J 29369-1 Universal Bearing Remover
1. Remove the inner axle shaft. Refer to *Inner Axle Housing Shaft and Housing Replacement (Except Bravada)* or *Inner Axle Housing Shaft and Housing Replacement (Bravada)*.
  2. Hold the inner axle shaft housing in a vise by the carrier mounting flange.
  3. Remove the inner axle shaft seal using a suitable seal remover.
  4. Remove the inner axle shaft bearing using the J 29369-1 and the J 23907.

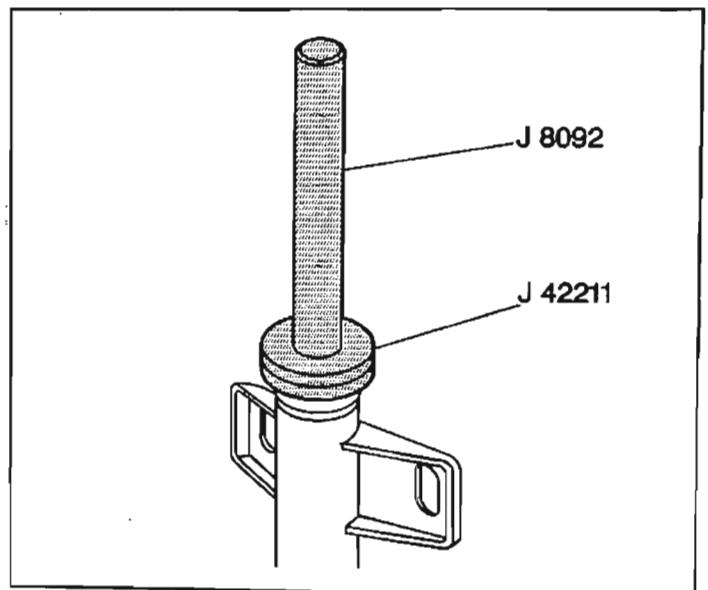


9105

## Installation Procedure

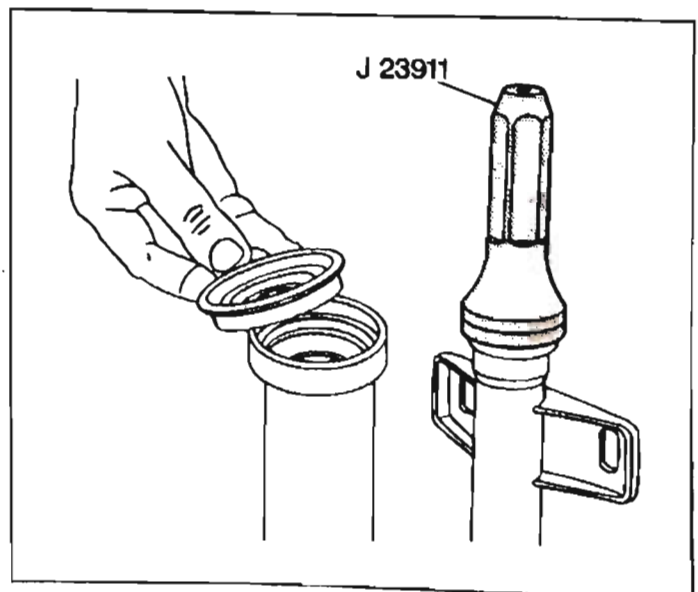
### Tools Required

- J 8092 Driver Handle
  - J 23911 Seal Installer
  - J 42211 Bearing Installer
1. Place the inner axle shaft housing to carrier flange flat on a level surface.
  2. Install the inner axle shaft bearing using the J 42211 and the J 8092.
- The bearing is installed to the proper depth when the tool is flush with the tube end.
3. Lubricate the bearing using axle lubricant. Refer to *Fluid and Lubricant Recommendations in Maintenance and Lubrication*.

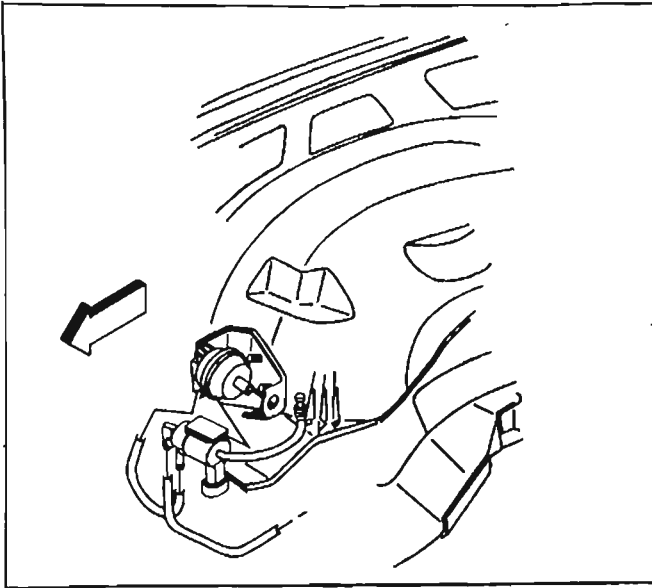


524680

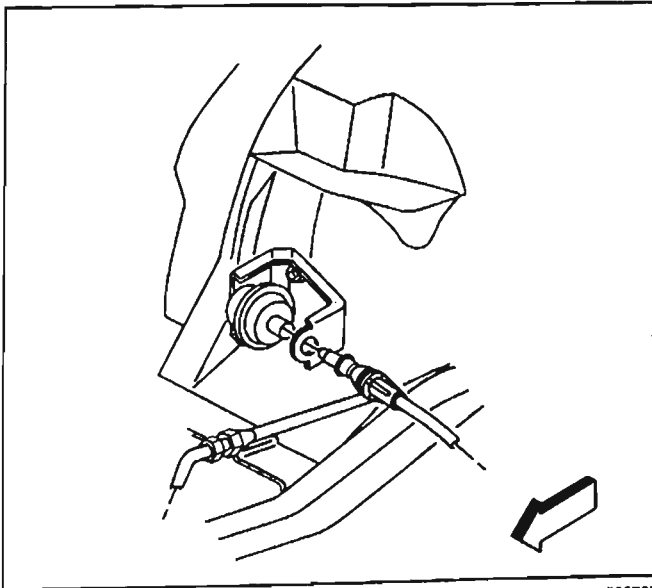
4. Install the inner axle shaft seal with the J 23911. Drive in the seal until the seal flange is flush with the tube end.
5. Install the inner axle shaft. Refer to *Inner Axle Housing Shaft and Housing Replacement (Except Bravada)* or *Inner Axle Housing Shaft and Housing Replacement (Bravada)*.



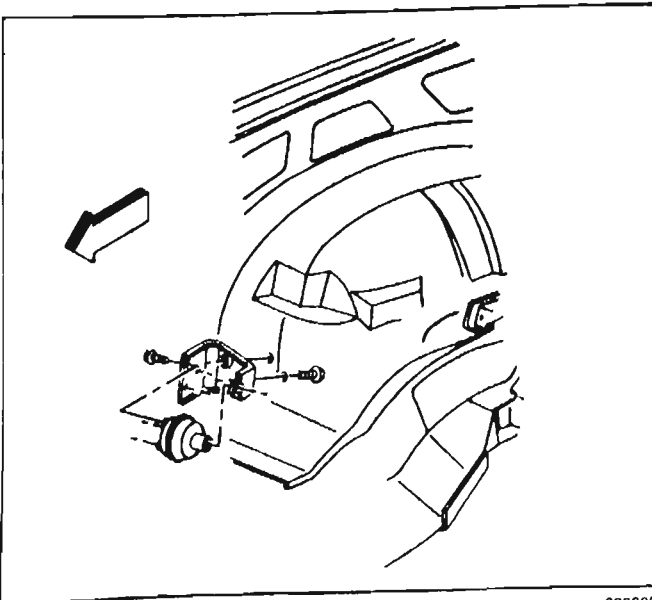
321864



392802



392797



392809

## Vacuum Actuator Replacement

### Removal Procedure

1. Remove the battery. Refer to *Battery Replacement* in Engine Electrical.
2. Remove the battery tray. Refer to *Battery Tray Replacement* in Engine Electrical.
3. Remove the vacuum hose from the vacuum actuator.
4. Remove the vacuum actuator cable.
5. Remove the bolts.
6. Remove the vacuum actuator.

**Installation Procedure**

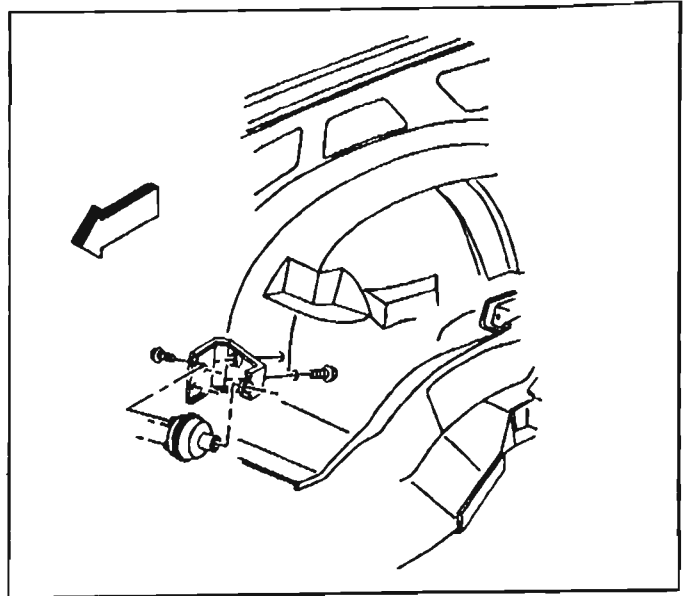
1. Install the vacuum actuator.

**Notice:** Refer to *Fastener Notice* in Cautions and Notices.

2. Install the bolts.

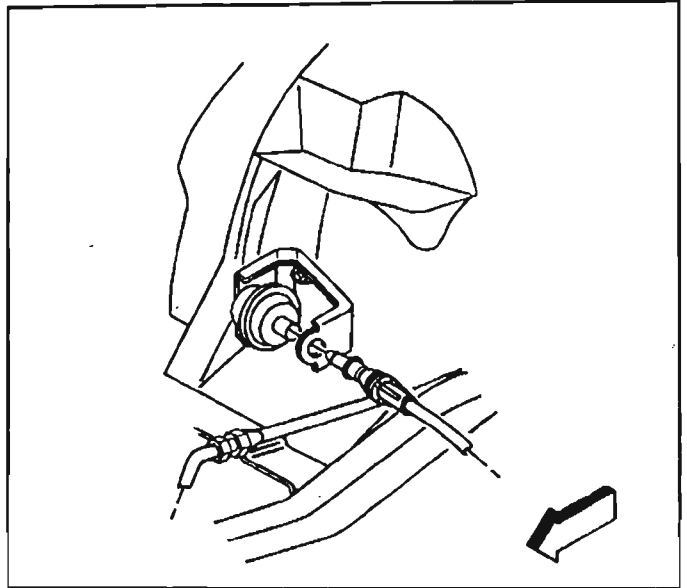
**Tighten**

Tighten the bolts to 1.4 N·m (13 lb in).



392809

3. Install the vacuum actuator cable.



392797

4. Install the vacuum hose.
5. Install the battery tray. Refer to *Battery Tray Replacement* in Engine Electrical.
6. Install the battery. Refer to *Battery Replacement* in Engine Electrical.



392802

## Drive Pinion Yoke Replacement

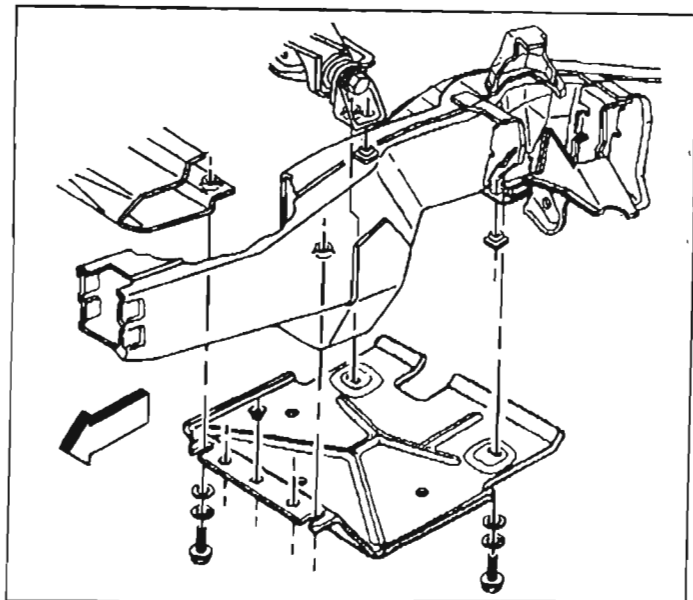
### Removal Procedure

#### Tools Required

J 8614-01 Pinion Yoke Holder

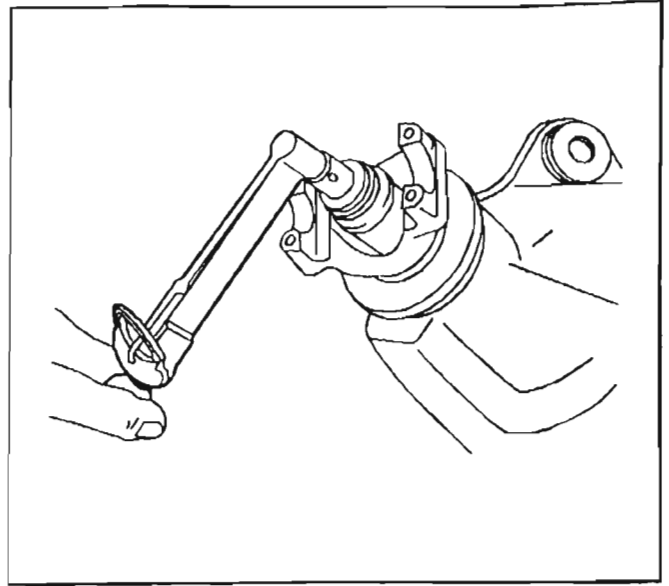
**Important:** Note the positions and accurately reference mark all driveline components relative to the disassembly of the propeller shaft and axles. These components include the propeller shafts, drive axles, pinion yokes and output shafts. The published specifications and torque values, as well as any measurements made prior to disassembly must also be followed. All components must be reassembled in the exact relationship to each other as when removed.

1. In order to free the steering linkage for movement, unlock the steering column.
2. Raise the vehicle. Support the vehicle with safety stands. Refer to *Lifting and Jacking the Vehicle* in General Information.
3. Remove the front wheels. Refer to *Tire and Wheel Removal and Installation* in Tires and Wheels.
4. Remove the front rotors. Refer to *Brake Rotor Replacement - Front* in Disc Brakes.
5. Remove the differential carrier shield, if equipped.
6. Remove the differential carrier shield bracket.
7. Remove the front propeller shaft. Refer to *Propeller Shaft Replacement - Front* in Propeller Shaft.



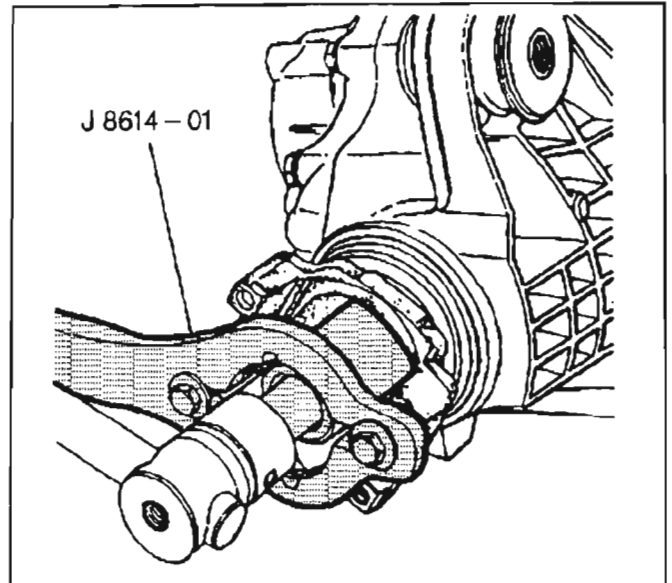
141840

8. Measure the amount of torque required to rotate the pinion. Use an inch-pound torque wrench. Record this measurement for reassembly. This will provide the combined preload for the following components:
  - The pinion bearings
  - The pinion seal
  - The carrier bearings
  - The axle bearings
  - The axle seals
  - The wheel drive shafts
  - The wheel bearings
9. Draw two arrows pointing at each other. One on the pinion stem and the other on the pinion yoke.
10. Record the number of exposed threads on the pinion stem for reference.



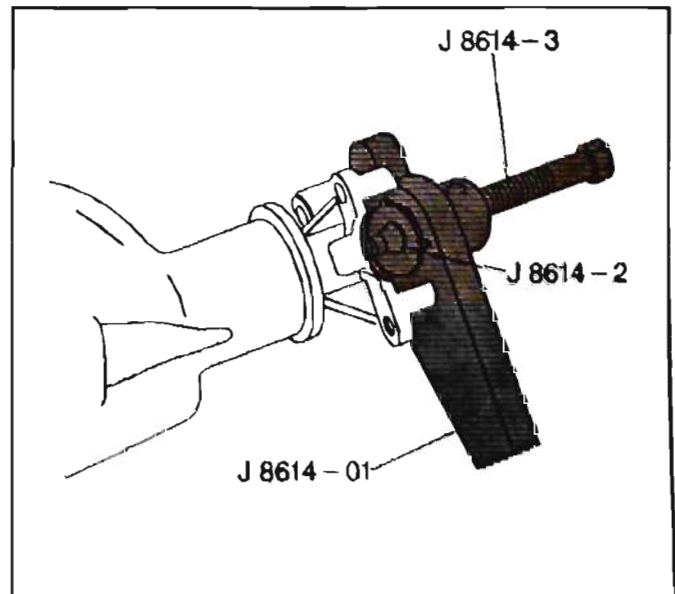
1497

11. Remove the pinion yoke nut and washer, using *J 8614-01* in order to secure the yoke.



9225

12. Remove the pinion yoke using *J 8614-01*. Provide a suitable container to catch the lubricant.



1494

9. Install the differential carrier shield bracket, if equipped.

**Tighten**

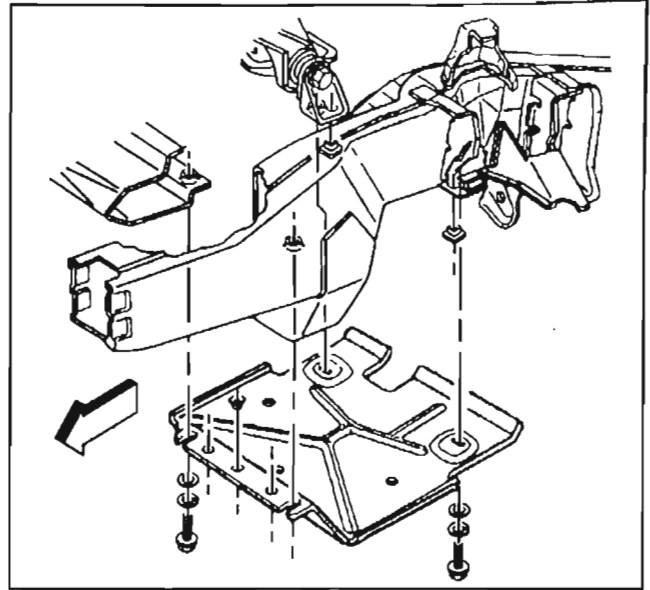
Tighten the bolt to 103 N·m (76 lb ft).

10. Install the differential carrier shield.

**Tighten**

Tighten the bolts to 25 N·m (18 lb ft).

11. Install the front rotors. Refer to *Brake Rotor Replacement - Front* in *Disc Brakes*.
12. Install the front wheels. Refer to *Tire and Wheel Removal and Installation* in *Tires and Wheels*.
13. Lower the vehicle.



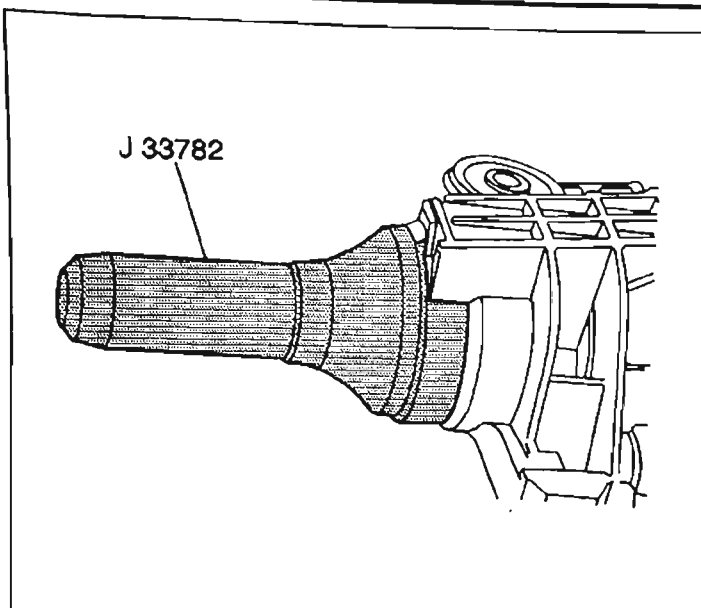
141840

## Pinion Oil Seal Replacement

### Removal Procedure

**Important:** Observe and reference mark the positions of all the driveline components, relative to the propeller shaft and axles, prior to disassembly. Reassemble all the components in the exact relationship to each other as the parts were when these parts were removed. You must follow any specifications and torque values, and any measurements made prior to disassembly.

1. Remove the drive pinion yoke. Refer to *Drive Pinion Yoke Replacement*.
2. Remove the pinion oil seal with a suitable seal removal tool. Do not damage the carrier.
3. Inspect the seal surface of the pinion yoke for the following conditions:
  - Tool Marks
  - Nicks
  - Damage such as a groove worn by the seal
4. Inspect the carrier bore for burrs that might cause leaks around the outside of the seal.



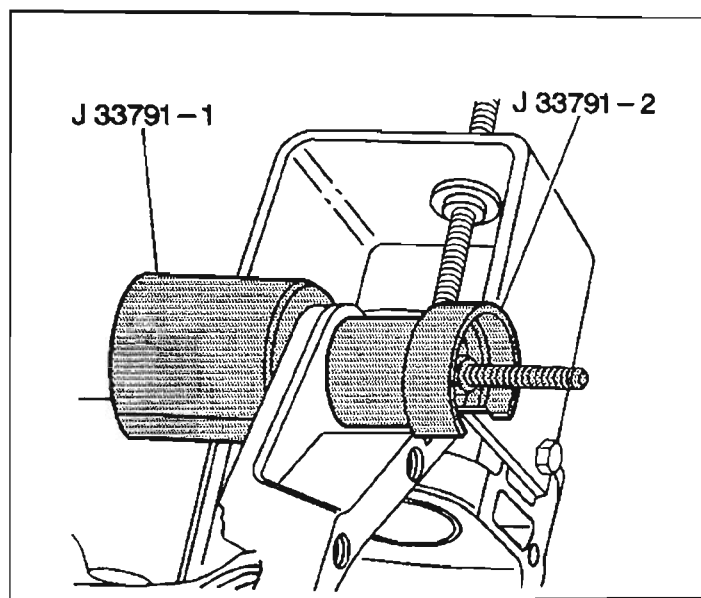
321794

### Installation Procedure

#### Tools Required

J 33782 Pinion Oil Seal Installer

1. Install the new pinion oil seal using the J 33782.
2. Install the drive pinion yoke. Refer to *Drive Pinion Yoke Replacement*.



3094

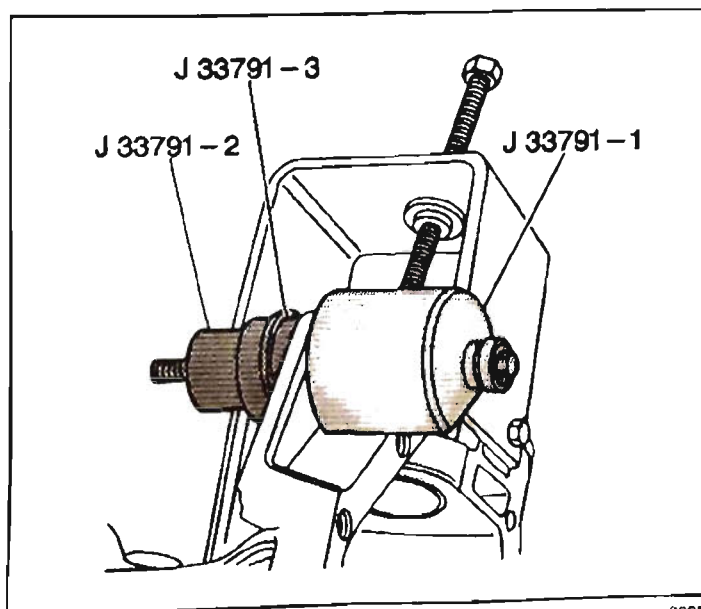
### Differential Carrier Assembly Bushing Replacement

#### Removal Procedure

#### Tools Required

J 33791 Bushing Remover and Installer Set

1. Remove the differential carrier assembly. Refer to *Differential Carrier Assembly Replacement*.
2. Remove the bushing using the J 33791.



3085

### Installation Procedure

#### Tools Required

J 33791 Bushing Remover and Installer Set

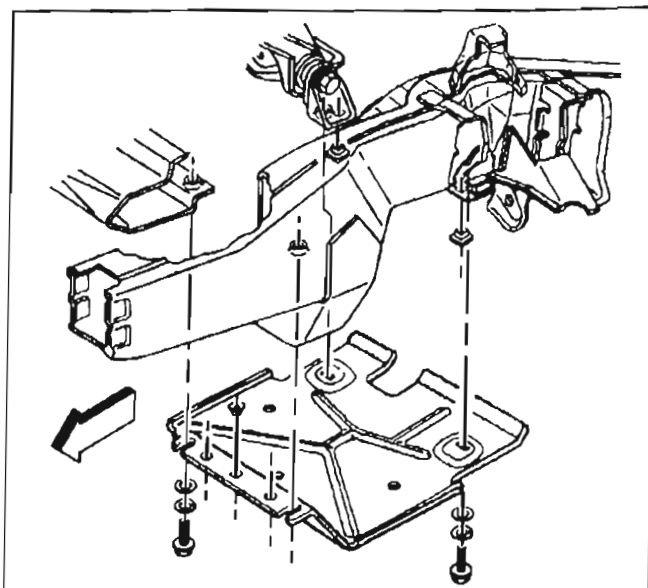
**Important:** Install the spacer (J 33791-3) between the bushing and the carrier ear in order to prevent the bushing from being pressed in too deeply.

1. Install the bushing using the J 33791.
2. Install the differential carrier assembly. Refer to *Differential Carrier Assembly Replacement*.

## Differential Carrier Assembly Replacement

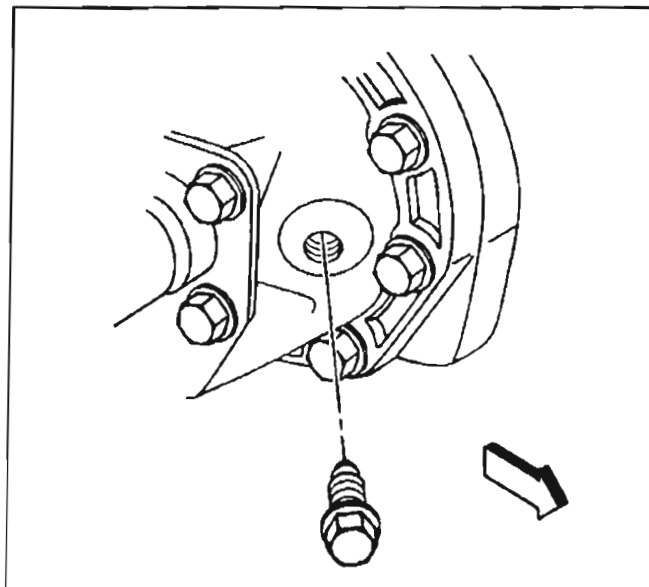
### Removal Procedure

1. Unlock the steering column so the steering linkage is free to move.
2. Raise the suitably support the vehicle. Refer to *Lifting and Jacking the Vehicle* in General Information.
3. Remove the differential carrier shield, if equipped.

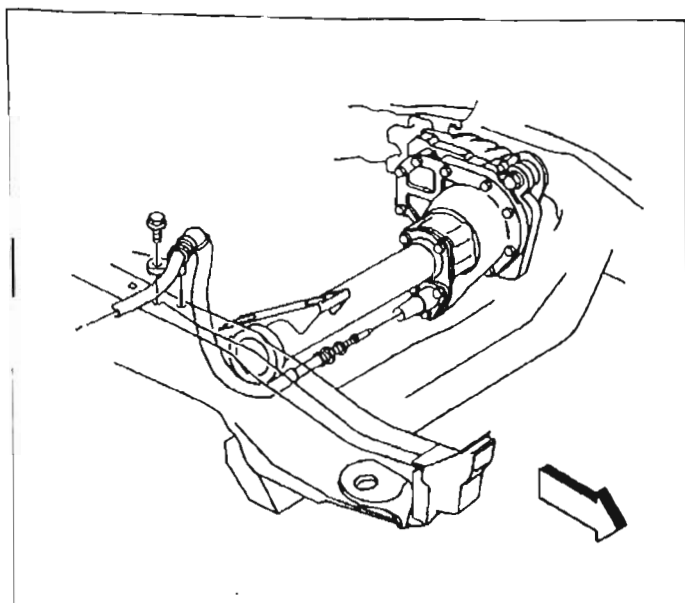


141840

4. Remove the drain plug and flat washer. Drain the lubricant from the carrier.

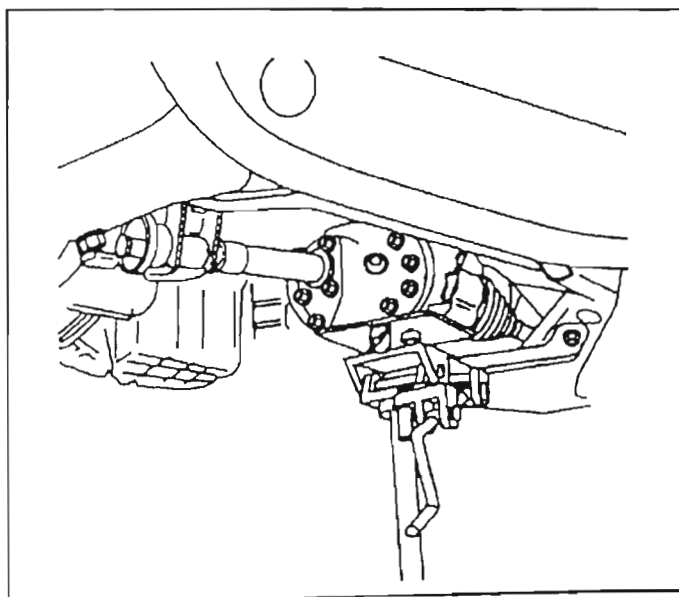


386125



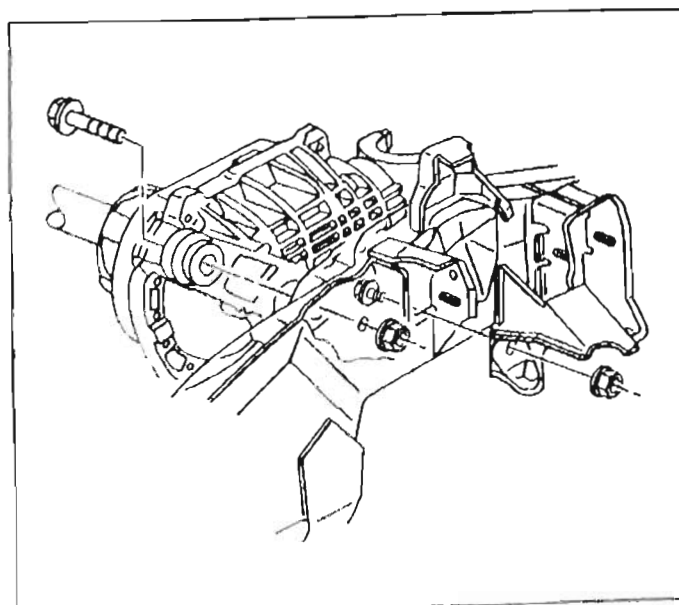
392514

5. Remove the vent hose. Refer to *Vent Hose Replacement*.
6. Remove the steering relay rod from the idler and pitman arms. Refer to *Relay Rod Replacement (4WD)* in *Steering Linkage*.
7. Remove the front propeller shaft. Refer to *Propeller Shaft Replacement - Front* in *Propeller Shaft*.
8. Remove the right and left wheel drive shafts. Refer to *Wheel Drive Shafts Replacement* in *Wheel Drive Shafts*.



161386

9. Support the carrier.
10. Remove the axle housing and shaft. Refer to *Inner Axle Housing Shaft and Housing Replacement (Except Bravada)* or *Inner Axle Housing Shaft and Housing Replacement (Bravada)*.



6833

11. Remove the carrier mounting bolts and nuts.
12. Remove the differential carrier assembly from the frame. Roll the carrier counterclockwise while lifting up to gain clearance from the mounting ears.

### Installation Procedure

1. Install the carrier assembly to the vehicle.

**Notice:** Refer to *Fastener Notice* in Cautions and Notices.

2. Install the carrier mounting bolts and nuts.

#### Tighten

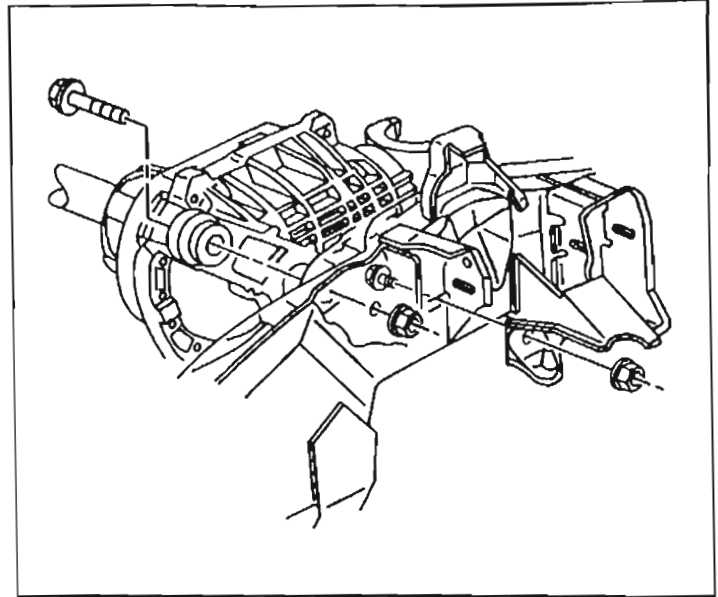
Tighten the bolts to 103 N·m (76 lb ft).

3. Install the axle housing and shaft. Refer to *Inner Axle Housing Shaft and Housing Replacement (Except Bravada)* or *Inner Axle Housing Shaft and Housing Replacement (Bravada)*.
4. Install the front propeller shaft retainers and bolts. Refer to *Propeller Shaft Replacement - Front* in Propeller Shaft.
5. Install the right and left drive axles. Refer to *Wheel Drive Shafts Replacement*.
6. Install the vent hose. Refer to *Vent Hose Replacement*.
7. Install the idler and pitman arms to the steering relay rod. Refer to *Relay Rod Replacement (4WD)* in Steering Linkage.
8. Install the drain plug and flat washer.

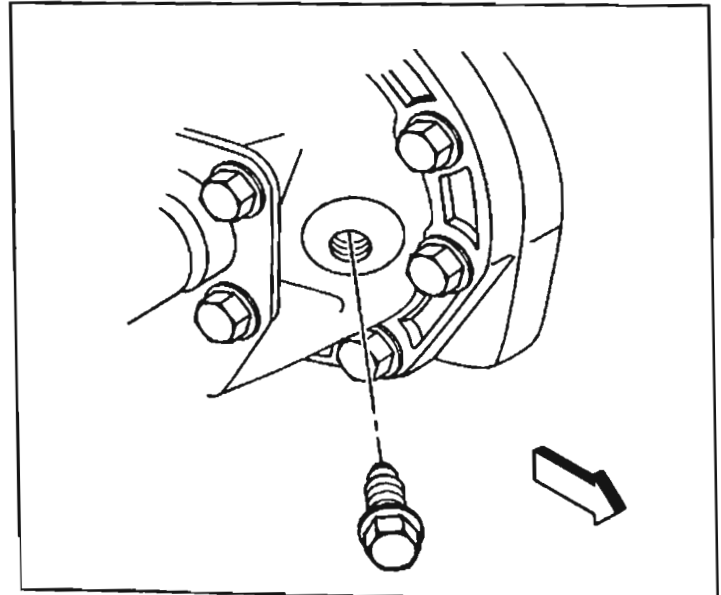
#### Tighten

Tighten the drain plug to 26 N·m (19 lb ft).

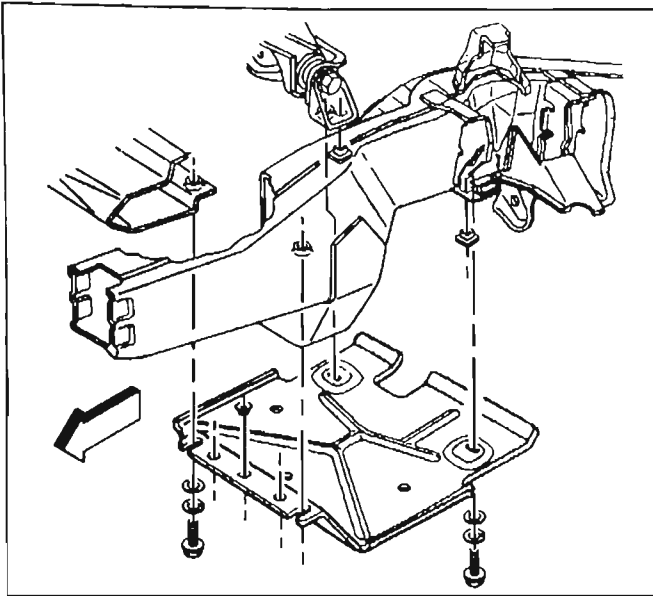
9. Inspect the axle lubricant level. Refer to *Fluid and Lubricant Recommendations* in Maintenance and Lubrication.



6833



386125



141840

10. Install the differential carrier shield, if equipped.  
**Tighten**  
Tighten the bolts to 25 N·m (18 lb ft).
11. Remove the safety stands and lower the vehicle.

### Ring and Pinion Gear Inspection

1. The ring and pinion gears are matched sets and must be replaced any time a replacement of either is necessary.
2. Inspect the pinion and the ring gear teeth for the following conditions:
  - Cracking
  - Chipping
  - Scoring
  - Excessive wear
3. Inspect the pinion gear splines for wear.
4. Inspect the pinion yoke splines for wear.
5. Inspect the fit of the pinion yoke on the pinion gear.
6. Inspect the sealing surface of the pinion yoke for nicks, burrs, or rough tool marks which will damage the inside diameter of the pinion seal and result in an oil leak.
7. Inspect all of the parts for wear and replace as necessary.

## Bearings Inspection

### Important:

- When replacing the worn or cracked bearings and the cups, replace the bearings in sets.
- The low mileage bearings may have very small scratches and pits on the rollers and the bearing cups from the initial preload.

Do not replace a bearing for this reason.

1. Inspect the bearings for smooth rotation after oiling.
2. Inspect the bearing rollers for wear.
3. Inspect the bearing cups for the following conditions:
  - Wear
  - Cracks
  - Brinelling
  - Scoring

## Thrust Washers, Shims, and Adjuster Sleeves Inspection

- Inspect the shims and thrust washers for cracks and chips. Replace the damaged shims with an equally sized service shim.
- Inspect the adjuster sleeves for damaged threads. Replace the sleeves if required.

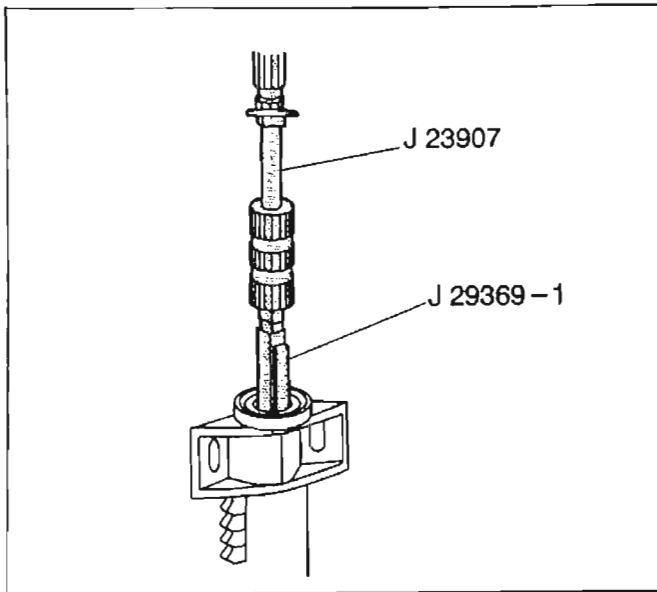
## Differential Carrier Overhaul (Except Bravada)

### Disassembly Procedure

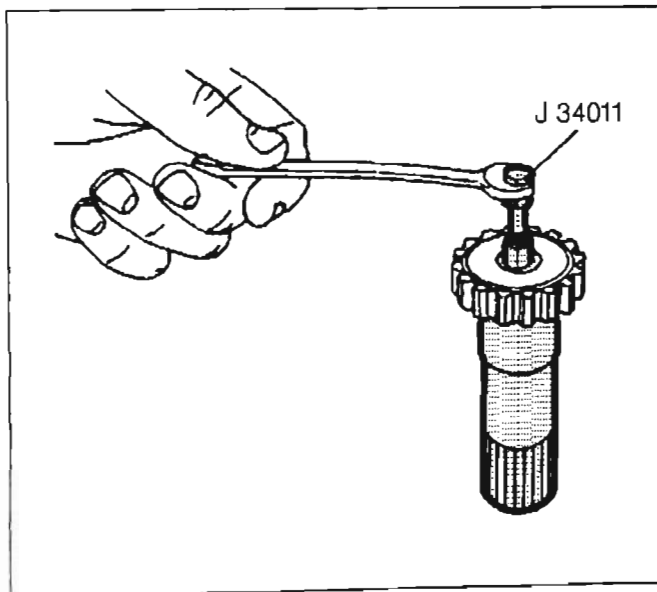
#### Tools Required

- *J 8107-2* Differential Side Bearing Remover
- *J 8614-01* Pinion Yoke Holder
- *J 21551* Output Shaft Bearing Remover
- *J 22888-20* Differential Side Bearing Puller
- *J 22912-01* Pinion Bearing Remover
- *J 23907* Slide Hammer
- *J 29369-1* Universal Bearing Remover
- *J 33791* Bushing Remover and Installer Set
- *J 33792* Side Bearing Adjuster Socket
- *J 33837* Pinion Bearing Cup Remover and Installer
- *J 34011* Pilot Bearing Remover
- *J 36611* Output Shaft Bearing Remover
- *J 42213* Side Bearing Adjuster Socket

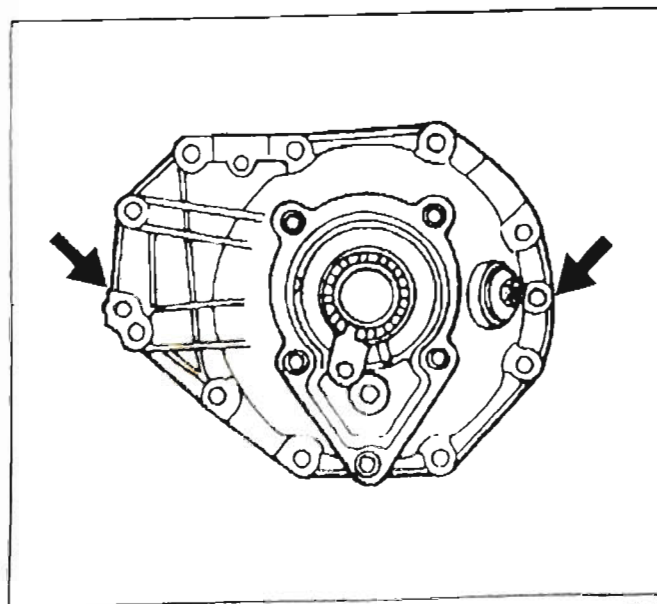
## 4-72 Front Drive Axle



9105



9106



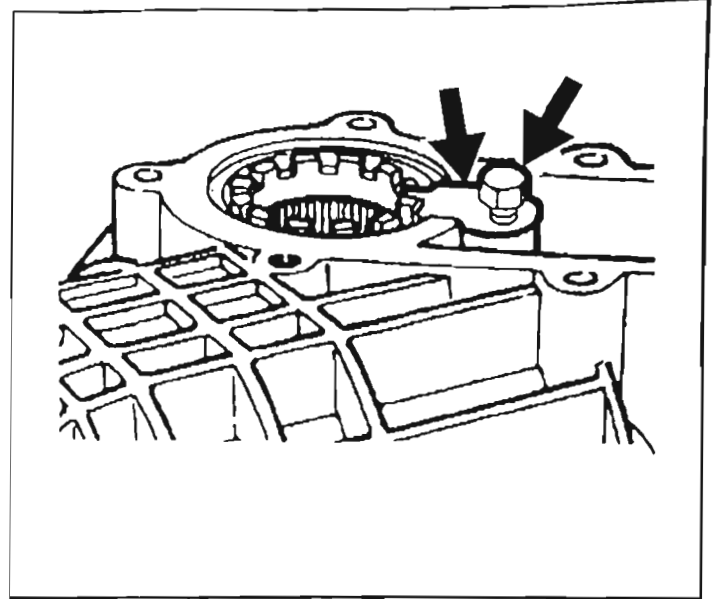
9029

1. Remove the bolts, the shift cable housing, and the spring.
2. Remove the tube and the thrust washer.
3. Remove the spring and shift shaft with fork.
4. Remove the axle shaft.
5. Remove the clutch gear with the retaining ring.
6. Remove the right inner axle shaft to housing seal using a suitable seal remover.
7. Remove the right inner axle shaft bearing using the *J 29369-1* and the *J 23907*.
8. Remove the thrust washer.
9. Remove the clutch sleeve and shaft.

10. Remove the pilot bearing from the clutch shaft using the *J 34011*.
11. Remove the washer.
12. Remove the left side carrier cover bolts.
13. Remove the left side cover and seal assembly.
14. Remove the carrier halves assembly bolts.

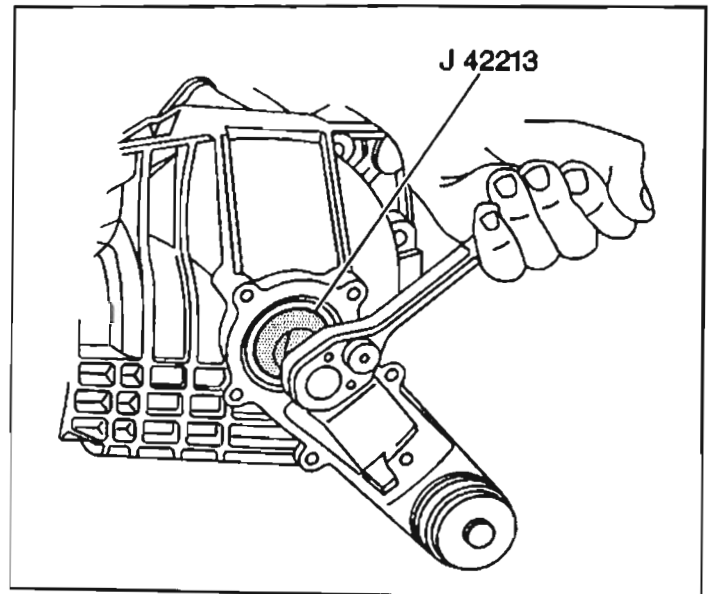
15. Separate the carrier. Insert a screwdriver into the slots provided and pry in order to separate the carrier.
16. Remove the differential case assembly.

17. Remove the bolts and lock tabs from the side bearing adjuster sleeves.
18. Remove the bearing cups and sleeves from the carrier.



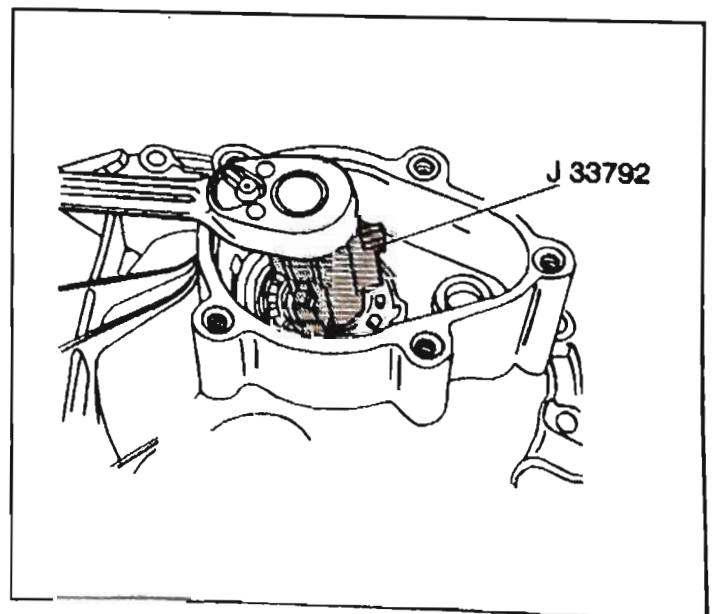
9031

19. Turn the left sleeve until the cup is pushed out of the carrier using the *J 42213*.



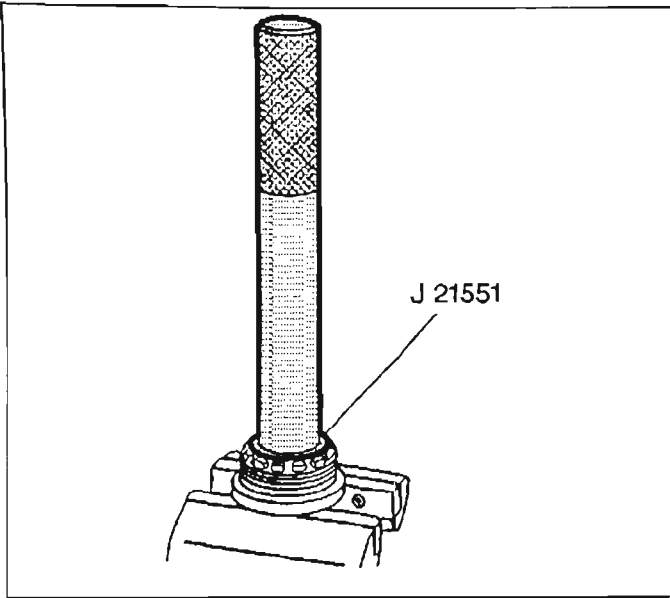
533981

20. Turn the right sleeve until the cup is pushed out of the carrier using the *J 33792*.



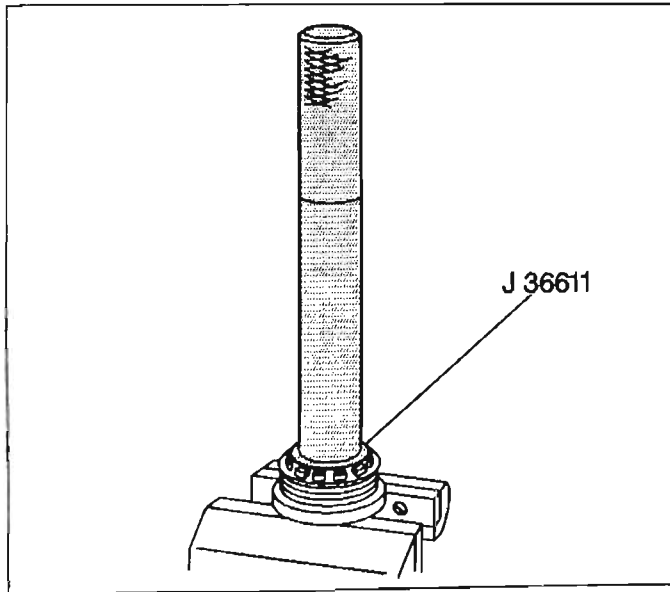
526751

- 21. Remove the bearing from the right adjuster sleeve using the *J 21551*.



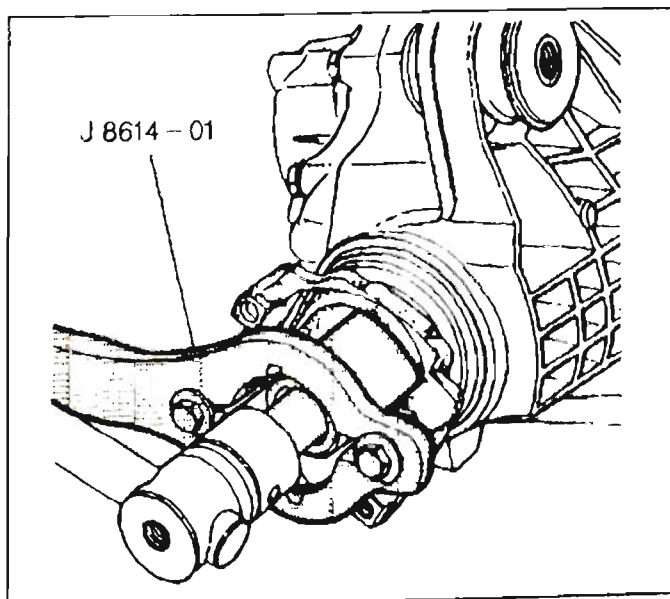
8700

- 22. Remove the bearing from the left adjuster sleeve using the *J 36611*.



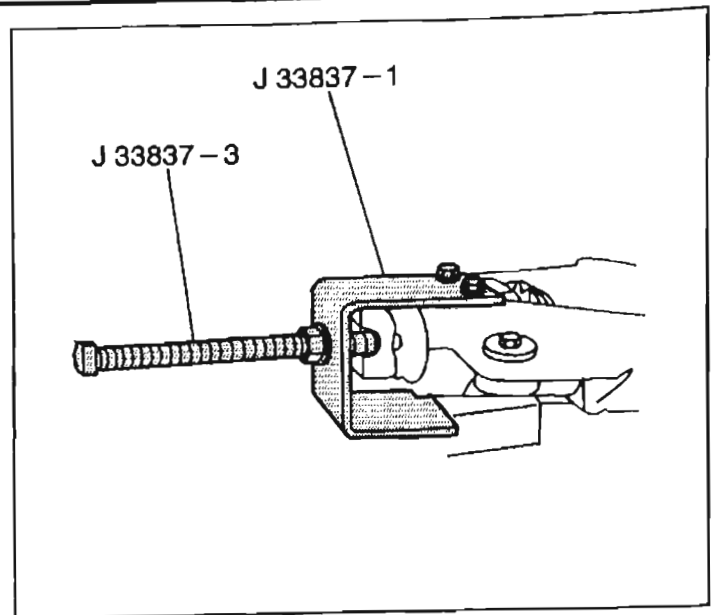
537196

- 23. Remove the pinion yoke nut and washer using the *J 8614-01*.



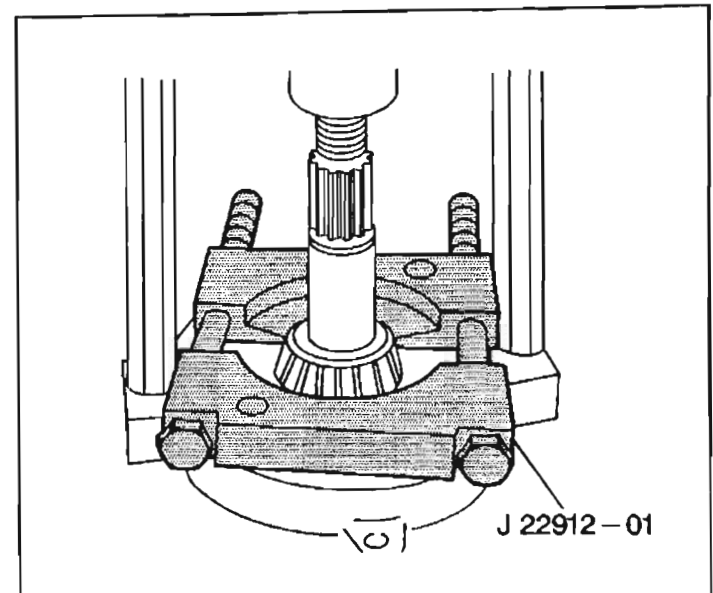
9225

24. Mount the left carrier case half and drive the pinion out of the carrier using the *J 33837 -1* and the *J 33837-3*.
25. Remove the pinion yoke and the deflector.
26. Remove the pinion with the spacer and the pinion bearing and shim.
27. Remove the spacer from the pinion.



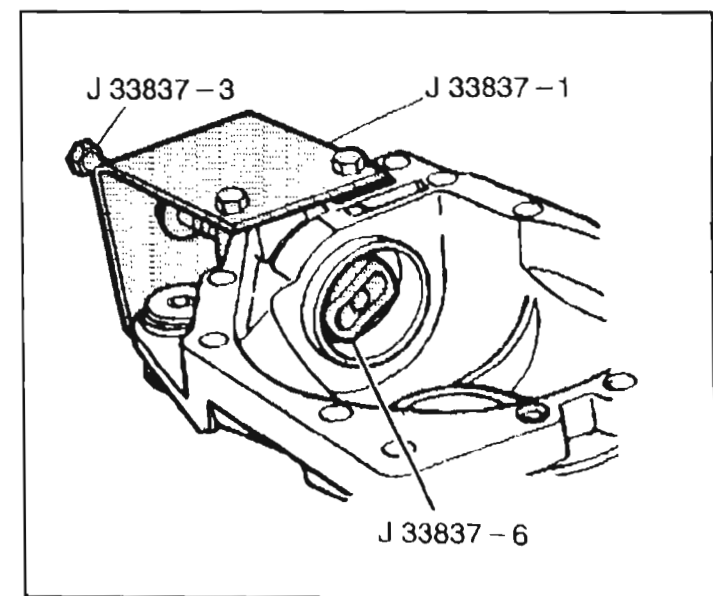
8701

28. Remove the bearing from the pinion using a press and the *J 22912-01*.
29. Remove the shim.
30. Remove the outer pinion bearing, the seal and the cup using the *J 33837 -1*, the *J 33837-3* and the *J 33837-6*.
  - 30.1. Insert the *J 33837-6* into the pinion bore.
  - 30.2. Thread the forcing screw (*J 33837-3*) into the *J 33837-6*.
  - 30.3. In order to pull the parts from the case, turn the forcing screw.

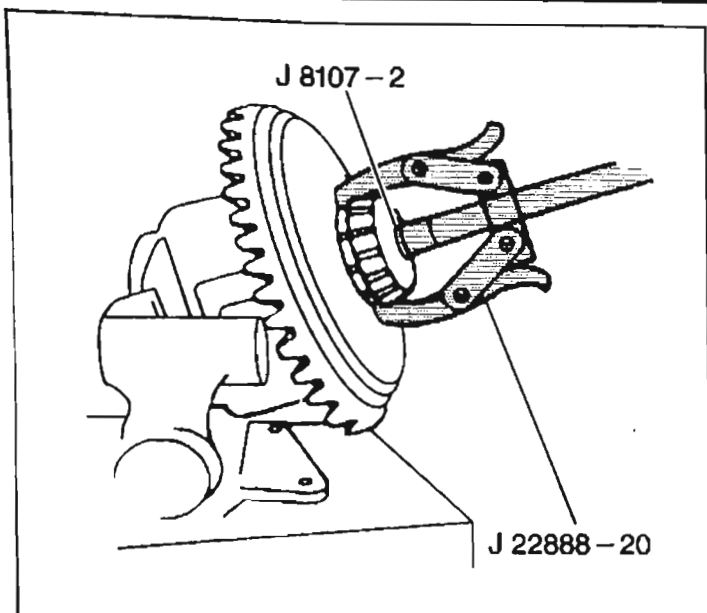


210154

31. Remove the inner bearing cup by pushing out using the *J 33837 -1*, the *J 33837-3* and the *J 33837-6*.
32. Remove the differential pinion bolt and shaft from the differential case.
33. Remove the differential pinion gears and the thrust washers.
34. Remove the side gears and the thrust washers. Mark the side gears and case for reinstallation in the original location.
35. Remove the ring gear mounting bolts.
36. Remove the ring gear. Drive the gear off using a brass drift and hammer. Do not pry between the ring gear and the case.

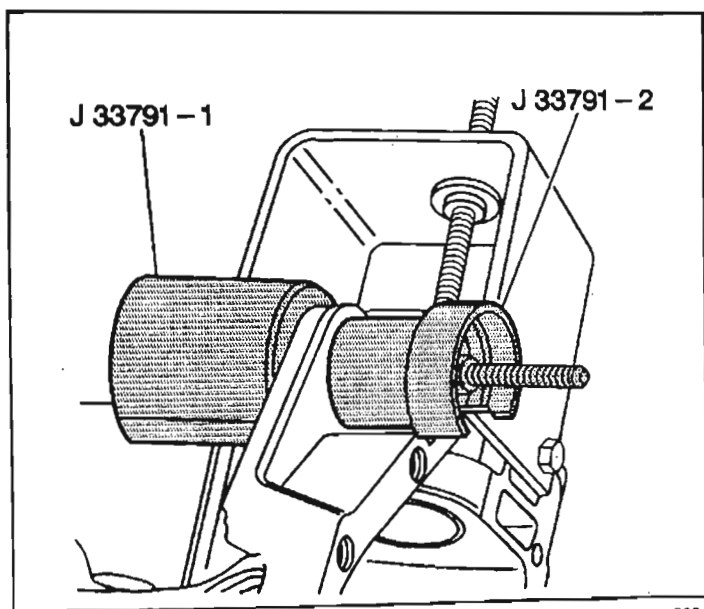


9036



526353

37. Remove the side bearings using the *J 22888-20* and the *J 8107-2*.



3094

38. Remove the case bushing using the *J 33791-1* and the *J 33791-2*.

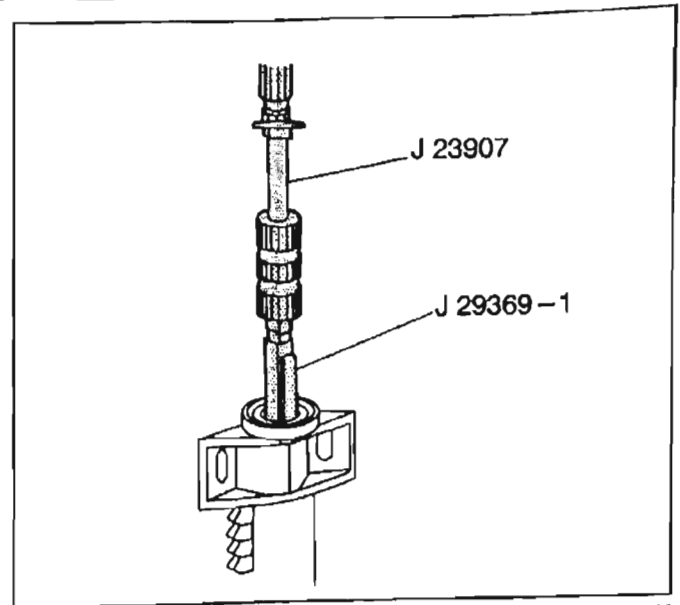
## Differential Carrier Overhaul (Bravada)

### Disassembly Procedure

#### Tools Required

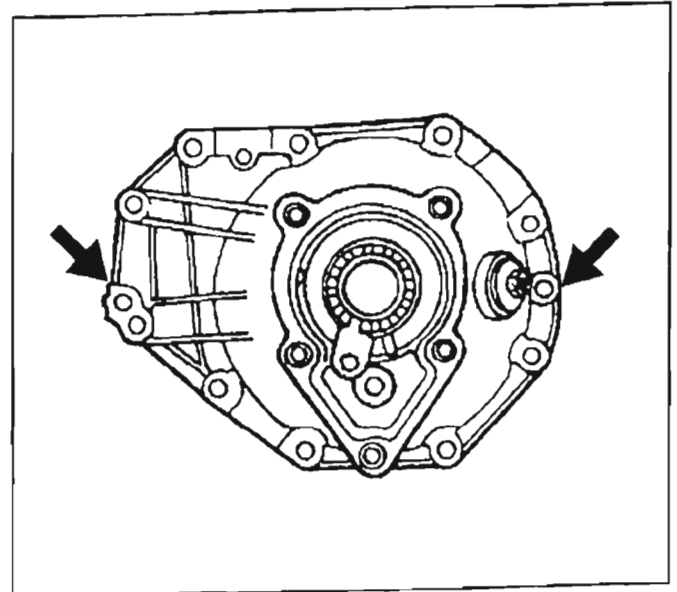
- *J 8107-2* Differential Side Bearing Remover
- *J 8614-01* Pinion Yoke Holder
- *J 21551* Output Shaft Bearing Remover
- *J 22888-20* Differential Side Bearing Puller
- *J 22912-01* Pinion Bearing Remover
- *J 23907* Slide Hammer
- *J 29369-1* Universal Bearing Remover
- *J 33791* Bushing Remover and Installer Set
- *J 33792* Side Bearing Adjuster Socket
- *J 33837* Pinion Bearing Cup Remover and Installer
- *J 36611* Output Shaft Bearing Remover
- *J 42213* Side Bearing Adjuster Socket

1. Remove the right inner axle shaft and the retaining ring.
2. Remove the axle tube to carrier mounting bolts.
3. Remove the axle tube.
4. Remove the right inner axle shaft to housing seal using a suitable seal remover.
5. Remove the right inner axle shaft bearing using the *J 29369-1* and the *J 23907*.
6. Pull the left output shaft from the carrier.
7. Remove the left side carrier cover bolts.
8. Remove the left side cover and seal assembly.
9. Remove the carrier halves assembly bolts.



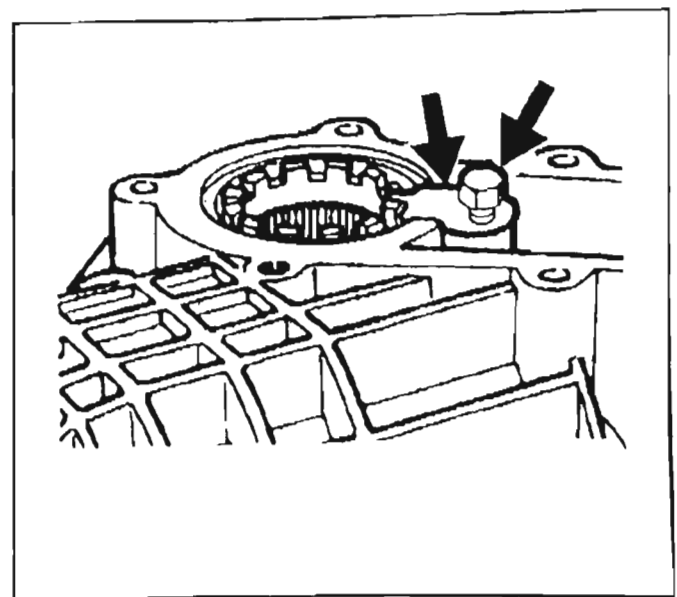
9105

10. Separate the carrier. Insert a screwdriver into the slots provided and pry the carrier apart.
11. Remove the differential case assembly.

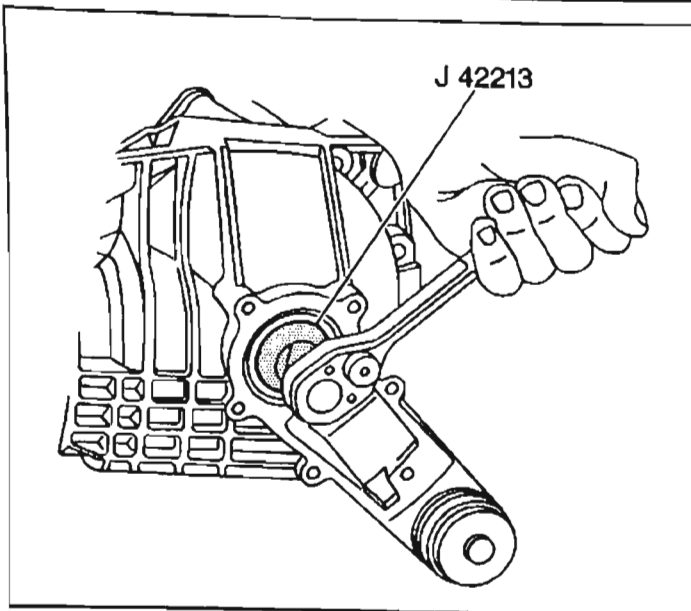


9029

12. Remove the bolts and the lock tabs from the side bearing adjuster sleeves.
13. Remove the bearing cups and sleeves from the carrier.

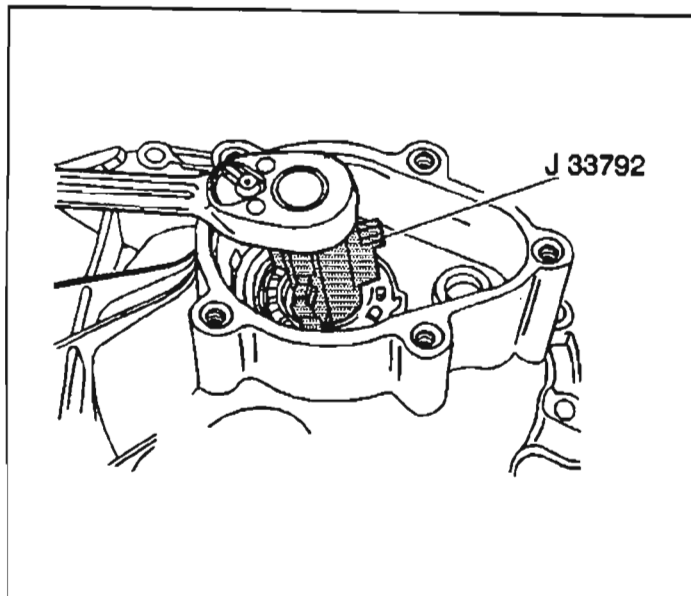


9031



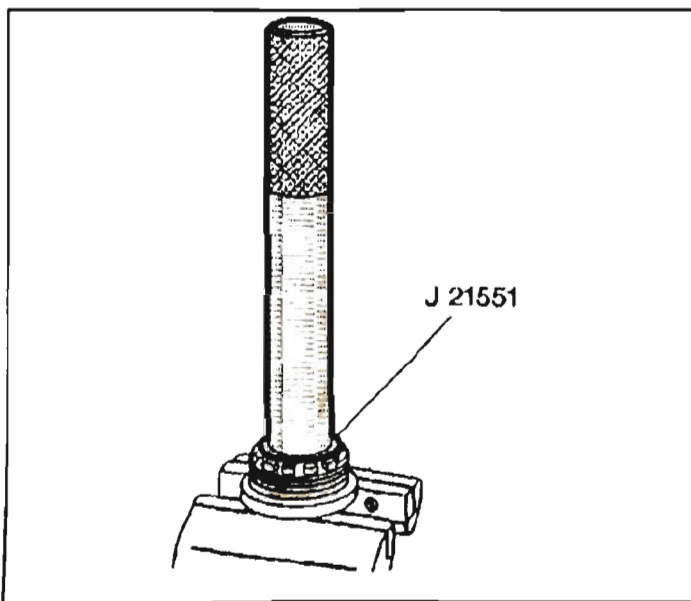
533981

14. Turn the left sleeve using the *J 42213* until the cup is pushed out of the carrier.



526751

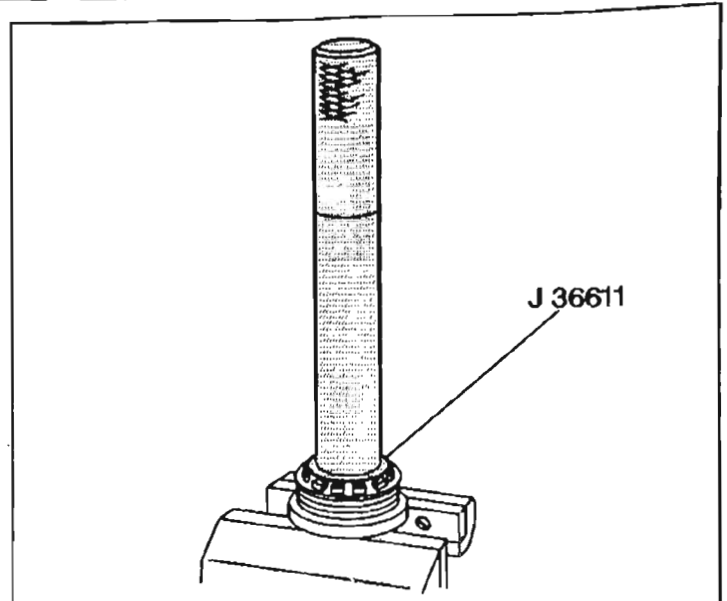
15. Turn the right sleeve using the *J 33792* until the cup is pushed out of the carrier.



8700

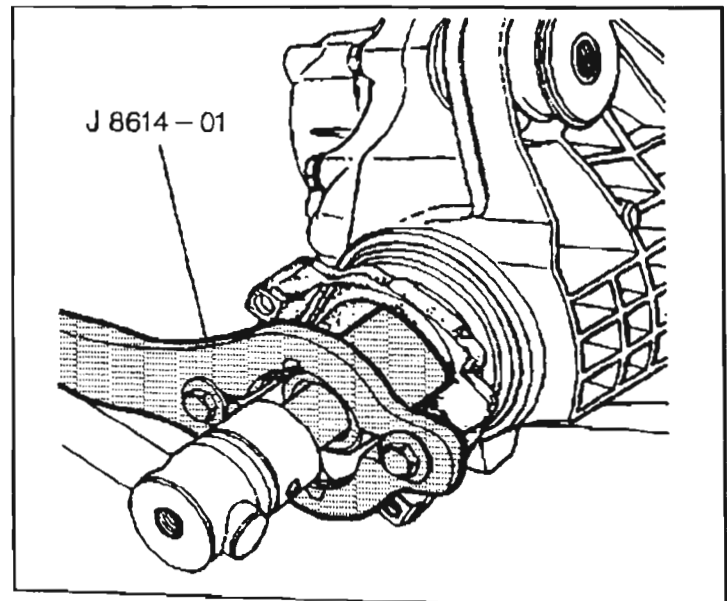
16. Remove the bearing from the right adjuster sleeve using the *J 21551*.

17. Remove the bearing from the left adjuster sleeve using the J 36611.



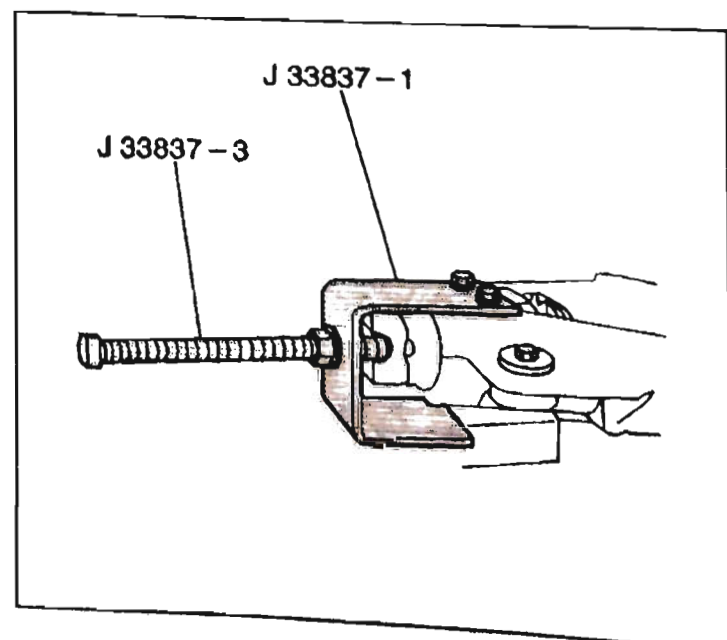
537196

18. Remove the pinion yoke nut and the washer using the J 8614-01.

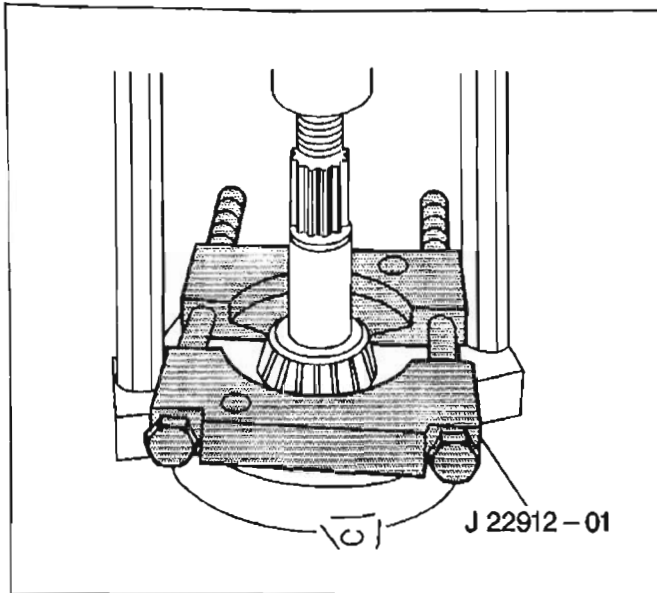


9225

19. Mount the left carrier case half and drive the pinion out of the carrier using the J 33837-1 and the J 33837-3.
20. Remove the pinion yoke and the deflector.
21. Remove the pinion with the spacer, the bearing and the shim.
22. Remove the spacer from the pinion.

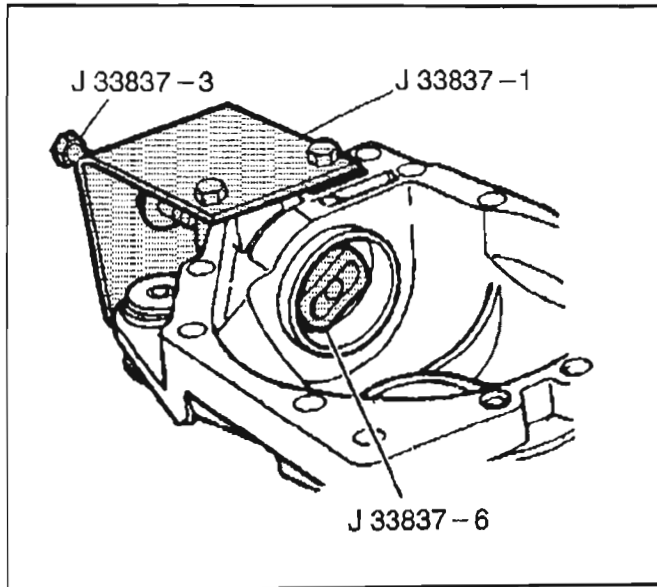


8701



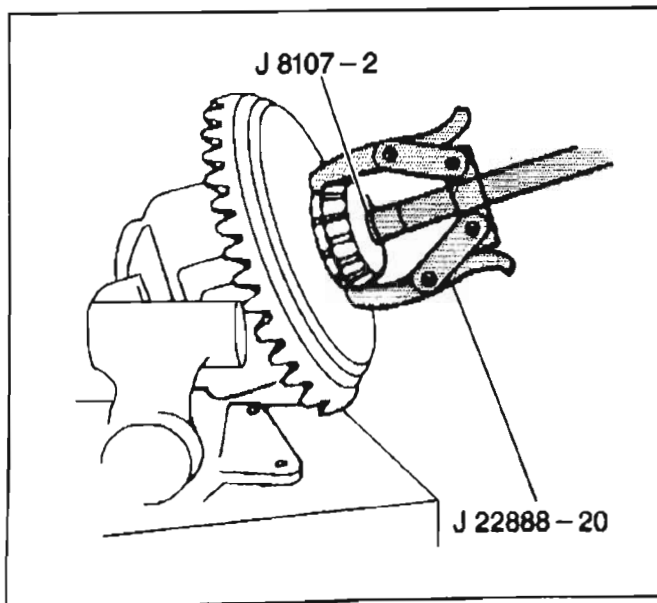
210154

23. Remove the bearing from the pinion using the *J 22912-01* and a press.
24. Remove the shim.
25. Remove the outer pinion bearing, the cup, and the seal using the *J 33837-1*, the *J 33837-3* and the *J 33837-6*.
  - 25.1. Insert the *J 33837-6* into the pinion bore.
  - 25.2. Thread the forcing screw (*J 33837-3*) into the *J 33837-6*.
  - 25.3. Turn the forcing screw in order to release the parts from the case.



9036

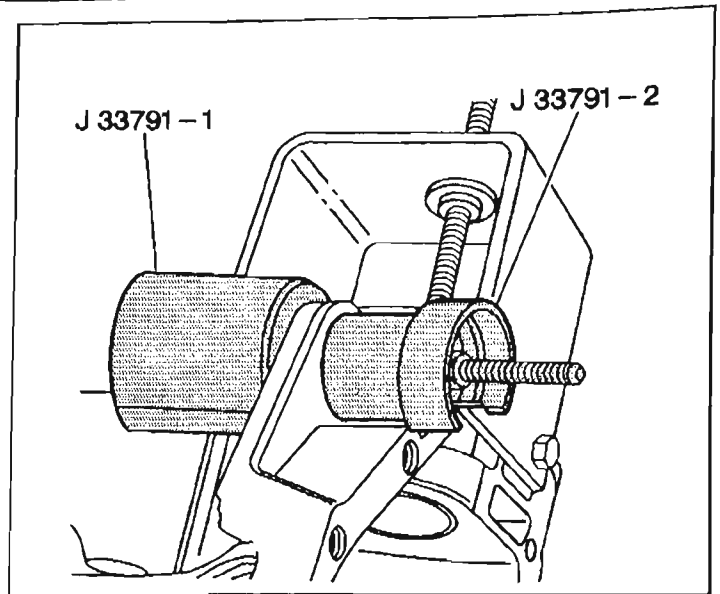
26. Remove the inner bearing cup by pushing the inner bearing cup out using the *J 33837-1*, the *J 33837-3* and the *J 33837-6*.
27. Remove the differential pinion bolt and the shaft from the differential case.
28. Remove the differential pinion gears and the thrust washers.
29. Remove the side gears and the thrust washers. Mark the side gears and the case for reference during reinstallation.
30. Remove the ring gear mounting bolts.
31. Remove the ring gear. Do not pry between the ring gear and the case. Drive the gear off using a brass drift and a hammer.



526353

32. Remove the side bearings using the *J 22888-20* and the *J 8107-2*.

33. Remove the case bushings using the J 33791 -1 and the J 33791-2.

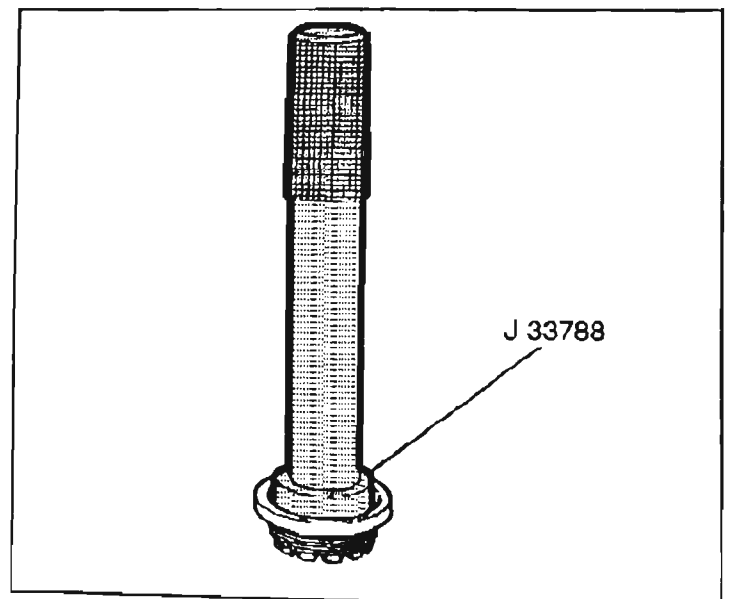


3094

### Differential Assembly Installation

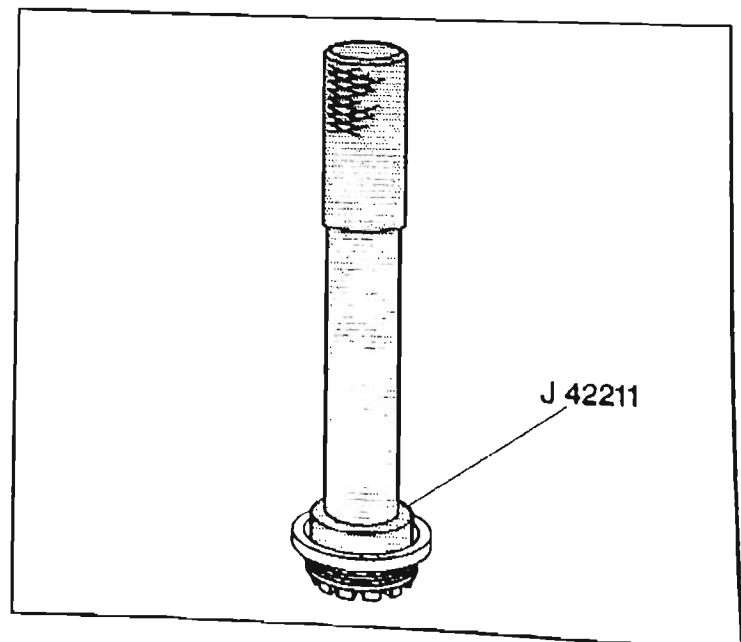
#### Tools Required

- J 8092 Driver Handle
  - J 23423-A Side Bearing Cup Installer
  - J 33788 Output Shaft Bearing Installer
  - J 33792 Side Bearing Adjuster Socket
  - J 42211 Bearing Installer
  - J 42213 Side Bearing Adjuster Socket
1. Install the bearing into the right sleeve using the J 33788.

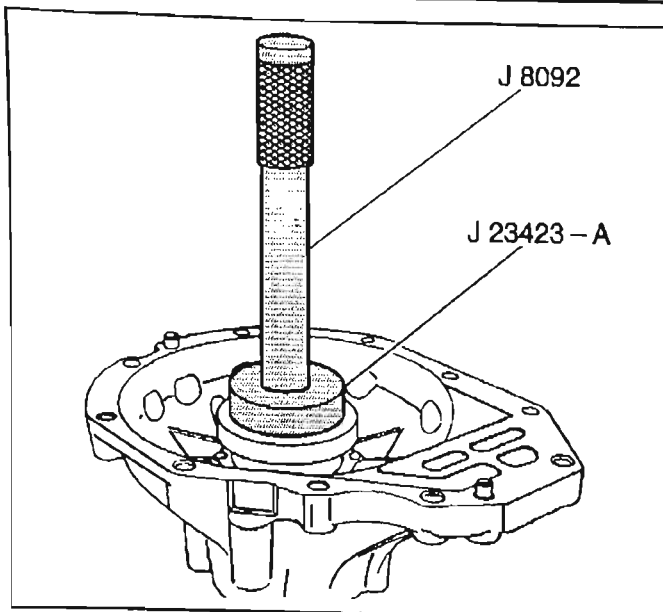


7829

2. Install the bearing into the left sleeve using the J 42211.
3. Install the sleeves into the carrier. Thread the sleeves in completely.

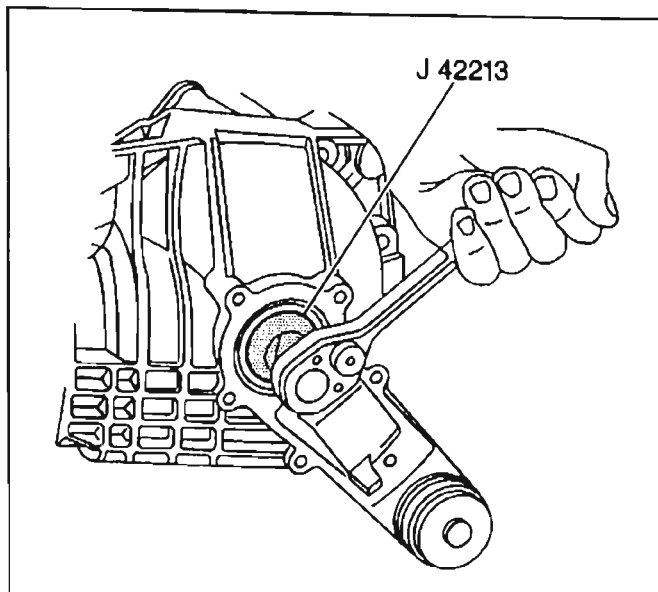


534219



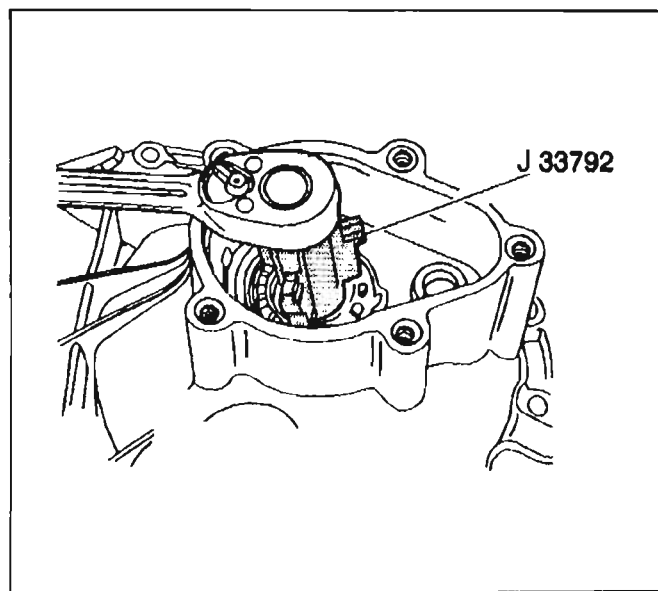
526731

4. Install the side bearing cups into the carrier using the *J 23423-A* and the *J 8092*.



533981

5. Install the differential case assembly to the carrier.
  - 5.1. Place the differential case assembly into the carrier half that contains the pinion gear.
  - 5.2. Turn the left sleeve in toward the differential case using the *J 42213* until backlash is felt between the ring and pinion gear.
6. Assemble the carrier halves. Do not use sealer at this time.



526751

7. If the carrier halves do not contact completely, back out the right hand adjusting sleeve. Use the *J 33792*.

**Notice:** Refer to *Fastener Notice* in Cautions and Notices.

8. Install the four carrier halves assembly bolts.
 

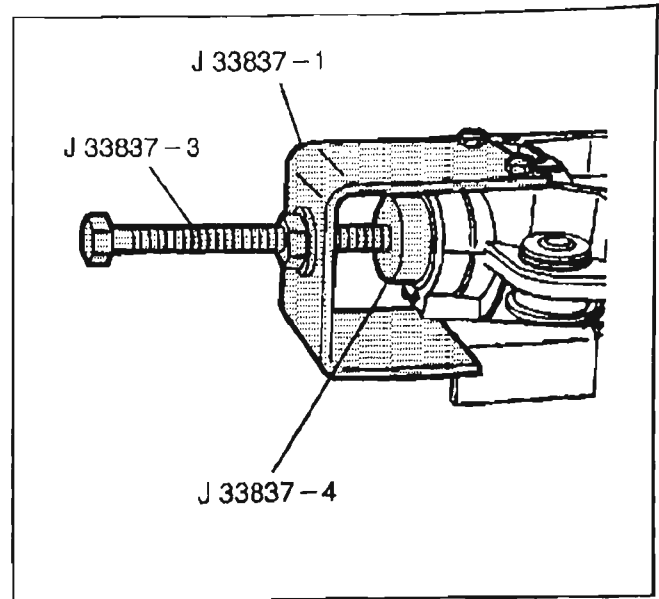
**Tighten**  
Tighten the bolts to 50 N·m (37 lb ft).

## Pinion Bearing Cup Installation

### Tools Required

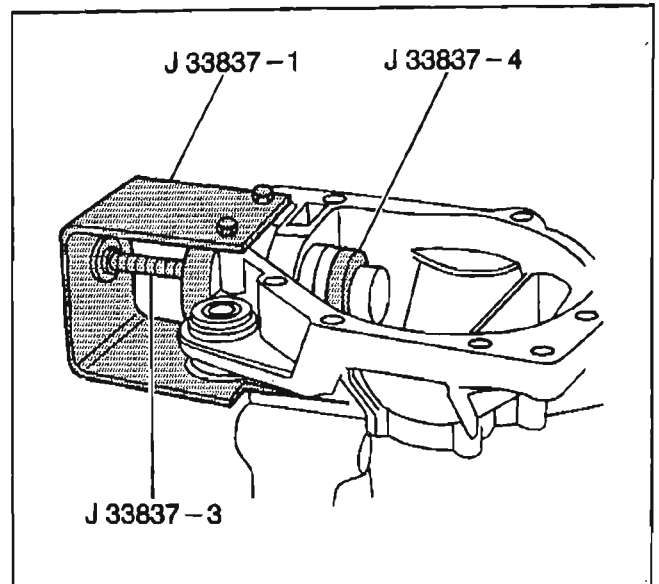
*J 33837* Pinion Bearing Cup Remover and Installer

1. Install the outer bearing into the case using the *J 33837 -1*, the *J 33837-3*, and the *J 33837-4*.



7824

2. Install the inner bearing into the case using the *J 33837 -1*, the *J 33837-3*, and the *J 33837-4*.



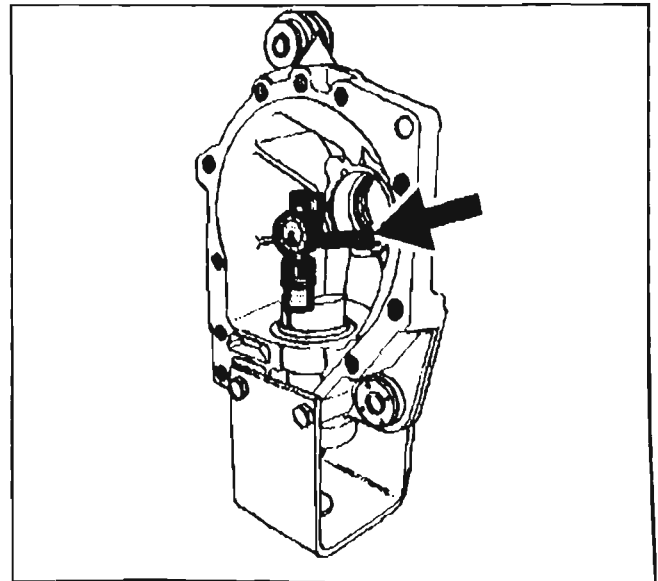
7826

## Pinion Depth Adjustment

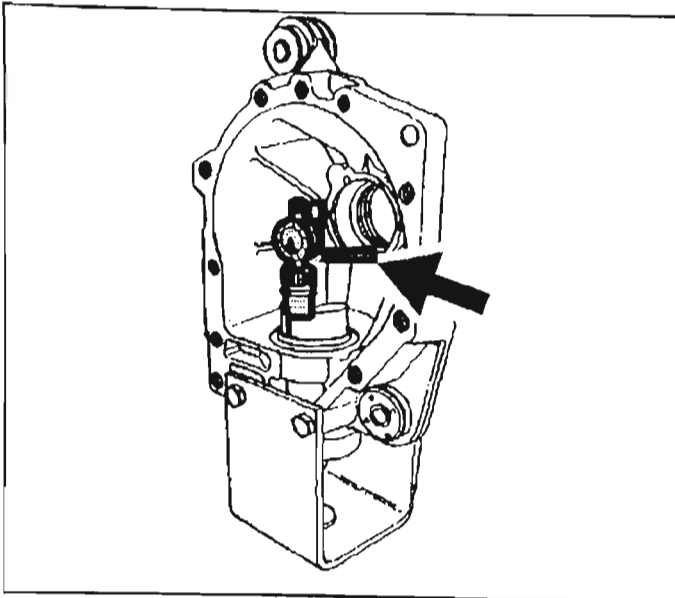
### Tools Required

- *J 33838* Pinion Shim Setting Gauge
- *J 29763* Dial Indicator

1. Adjust the pinion depth by selecting a shim of the proper thickness.
2. Lubricate the inner and outer pinion bearings liberally using axle lubricant.
3. Hold the pinion bearings in position and install the *J 33838*.

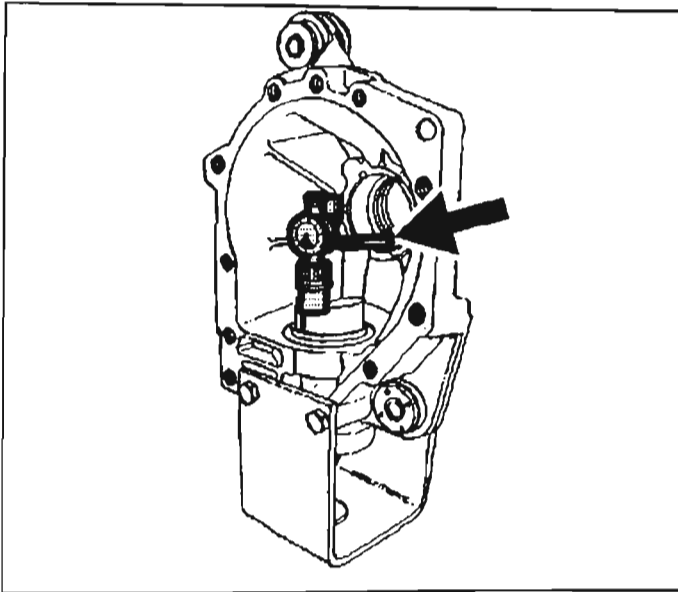


7827



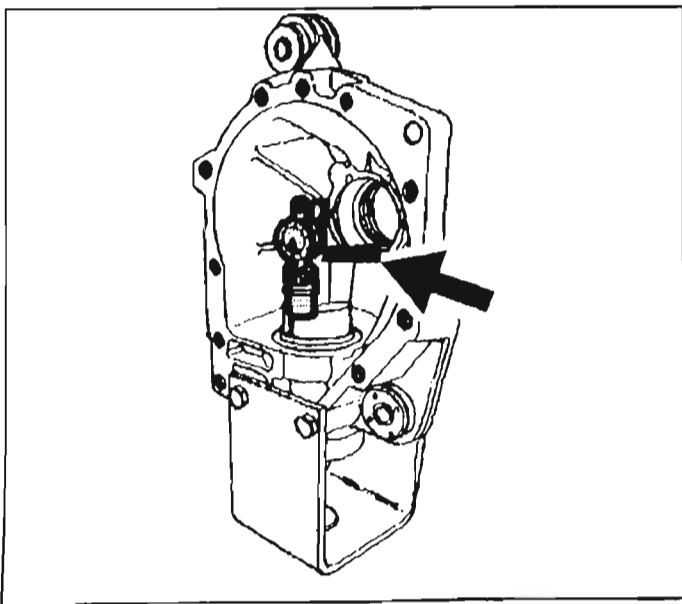
7828

4. Install the *J 29763*.
  - 4.1. Set the dial indicator at ZERO.
  - 4.2. Position the indicator in the *J 33838*.
  - 4.3. Push the dial indicator downward until the needle rotates approximately 3/4 turns to the right.
5. Tighten the dial indicator in this position.



7827

6. Set the button of the *J 33838* on the differential bearing bore.
7. Rotate the tool slowly back and forth until the dial indicator reads the lowest point of the bore. Set the dial indicator to ZERO. Repeat the rocking action of the tool in order to verify the ZERO setting.



7828

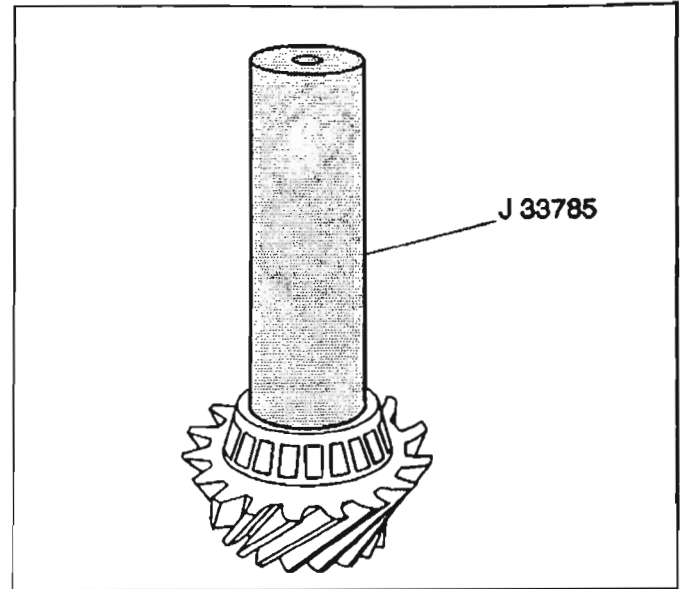
8. After you obtain and verify the ZERO setting, move the tool button out of the differential side bearing bore. Record the dial indicator reading. The dial indicator reading equals the shim size. For example, if the dial indicator reads 0.84 mm (0.033 in) in step 8, a 0.84 mm (0.033 in) shim is required.
9. Remove the tools and bearing cones.

## Pinion Installation

### Tools Required

- J 8614-01 Pinion Yoke Holder
- J 33782 Pinion Oil Seal Installer
- J 33785 Pinion Bearing Installer

1. Ensure that the bearing cups are installed. Refer to *Pinion Bearing Cup Installation*.
2. Install the selective shim between the inner bearing and the gear shoulder.
3. Install the inner pinion bearing onto the pinion gear using the J 33785.
4. Install a new collapsible spacer onto the pinion gear.
5. Lubricate the pinion bearings using axle lubricant.
6. Install the outer pinion bearing into the carrier.



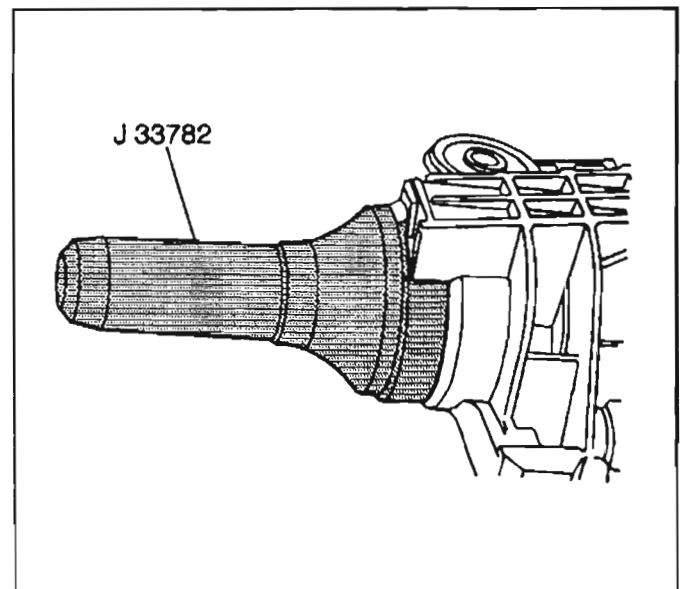
527662

7. Install the pinion seal using the J 33782.
8. Install the pinion gear (with the inner bearing and the spacer) into the carrier.
9. Apply sealant (GM P/N 12346004) to the inside sealing surface of the pinion yoke.
10. Apply special seal lubricant (GM P/N 12377985) to the outside sealing surface of the pinion yoke.

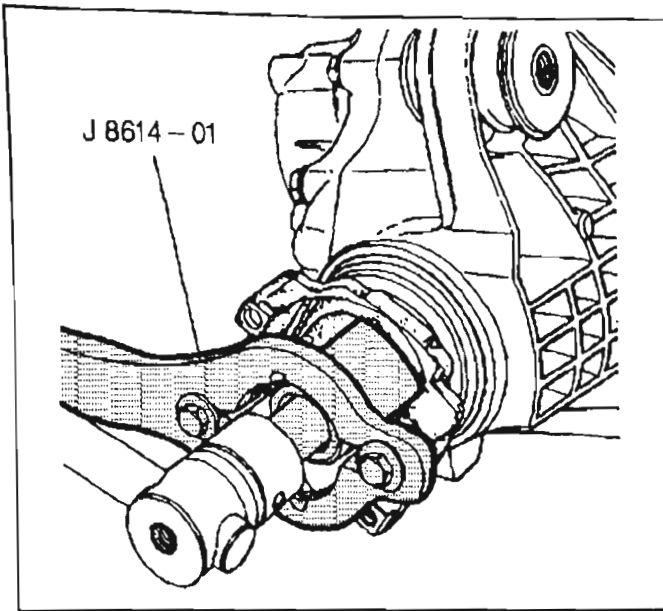
**Notice:** Do not hammer the pinion flange/yoke onto the pinion shaft. Pinion components may be damaged if the pinion flange/yoke is hammered onto the pinion shaft.

**Important:** Install the pinion yoke in the same position as marked during removal in order to maintain driveline balance.

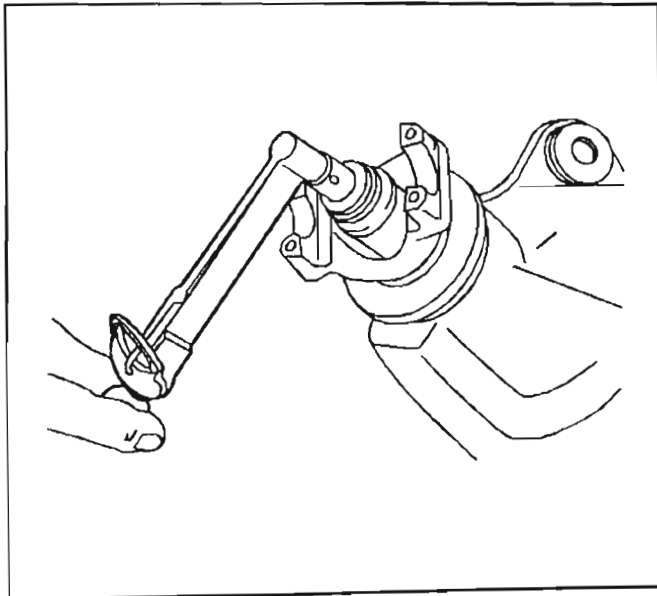
11. Install the drive pinion yoke by tapping the yoke using a soft-faced hammer until a few pinion shaft threads show through the yoke. The pinion will need to be held in place from inside the carrier half.



321794



9225



1497

**Notice:** Refer to *Fastener Notice* in Cautions and Notices.

**Important:** Reference the number of exposed threads on the pinion stem recorded during removal.

12. Install the washer and a new nut using the *J 8614-01*.

#### **Tighten**

Tighten the nut until the pinion end play is just taken up. Rotate the pinion while tightening the nut in order to seat the bearings.

**Important:** If the pinion bearing preload is exceeded, the pinion will have to be removed and a new collapsible spacer installed.

13. Measure the pinion bearing preload using an inch-pound torque wrench.
  - 13.1. Rotate the pinion with the torque wrench and observe the reading.
  - 13.2. The correct preload is 1.7–2.8 N·m (15–25 lb in).

#### **Tighten**

Tighten the nut in small increments, as needed, until the preload is correct.

14. Once the specified preload is obtained, rotate the pinion several times in order to ensure the bearings are seated. Recheck the preload and adjust if necessary.

## **Differential Case Assembly Assemble**

### **Tools Required**

- *J 8092* Driver Handle
- *J 33790* Differential Side Bearing Installer

1. Install the thrust washers and side gears into the differential case. If reusing the original gears and washers, install the gears on the same side from which the parts were removed.
2. Install the pinion gears.
  - 2.1. Position one pinion gear between the side gears. Rotate the gears until the pinion gear is directly opposite the opening in the case.
  - 2.2. Place the other gear between the side gears. Ensure that the holes in both pinion gears are aligned.

3. Install the thrust washers. Rotate the pinion gears toward the opening in order to permit the thrust washers to slide in.
4. Install the shaft and the bolt.
5. Install the ring gear onto the differential case.

**Notice:** Refer to *Fastener Notice* in Cautions and Notices.

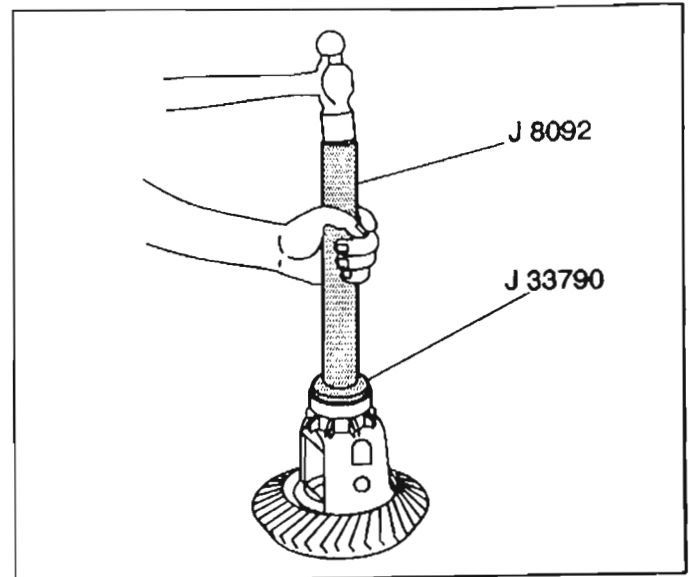
**Important:** Always install new bolts. Do not reuse the old bolts.

6. Install the ring gear mounting bolts.

**Tighten**

Tighten the bolts, in progressive steps, to 80 N·m (59 lb ft).

7. Install the side bearings using the *J 8092* and the *J 33790*.



526844

## Backlash Inspection and Adjustment

### Tools Required

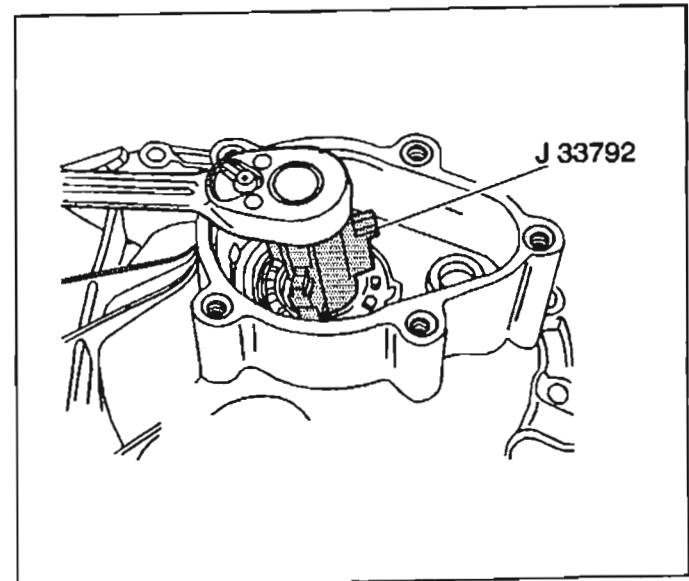
- *J 8001* Dial Indicator Set
- *J 33792* Side Bearing Adjuster Socket
- *J 42213* Side Bearing Adjuster Socket

**Notice:** Refer to *Fastener Notice* in Cautions and Notices.

1. Tighten the right sleeve using the *J 33792*.

**Tighten**

Tighten the right sleeve to 140 N·m (103 lb ft).

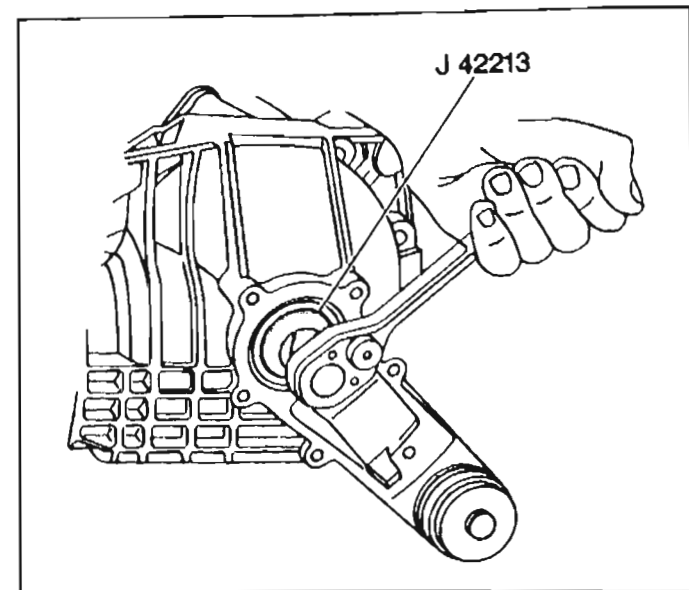


526751

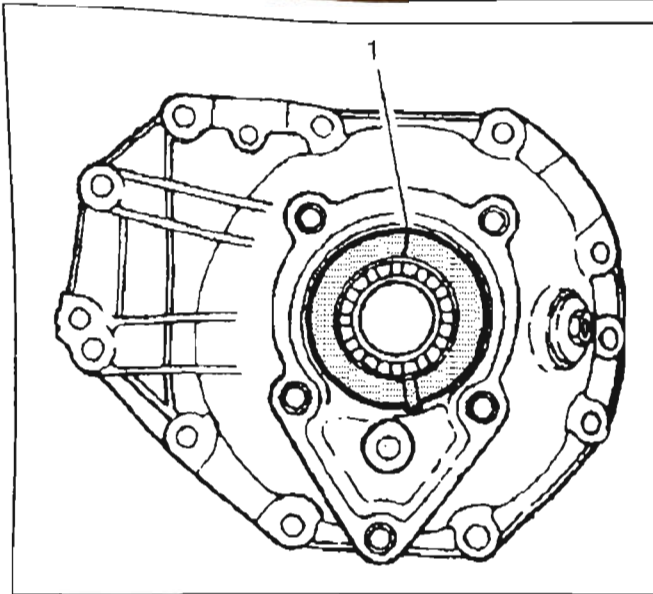
2. Tighten the left sleeve using the *J 42213*.

**Tighten**

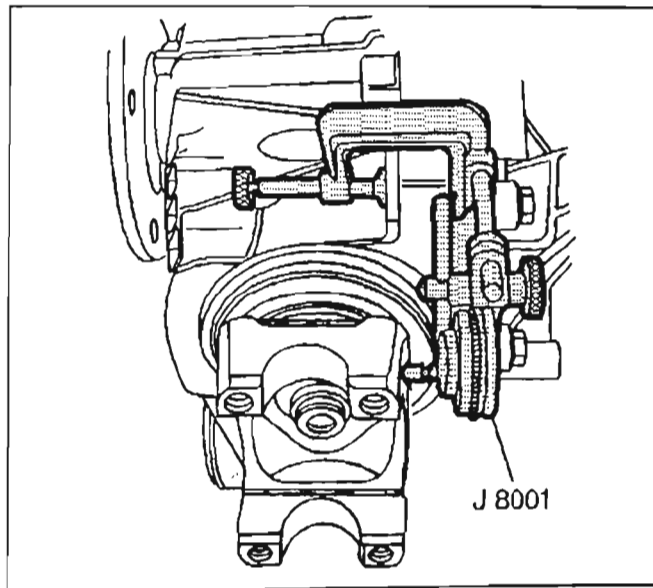
Tighten the left sleeve to 140 N·m (103 lb ft).



533981



7831



7833

3. Mark the location of the adjusting sleeves in relation to the carrier halves (1) in order to count the notches in the adjusting sleeves when turned.
  4. Turn the right adjusting sleeve out two notches using the *J 33792*.
  5. Turn the left adjusting sleeve in one notch using the *J 42213*.
  6. Rotate the pinion several times in order to seat the bearings.
7. Install the *J 8001* in order to ensure that the button contacts the outer edge of the pinion yoke. The plunger must be at a right angle to the pinion yoke.
  8. Move the pinion yoke through the yoke's free play while holding the differential case. Record the dial indicator reading.
  9. Divide the dial indicator reading by two in order to obtain the actual backlash. For example, a dial indicator reading of 0.16 mm (0.006 in) means that there is actually 0.08 mm (0.003 in) backlash.
  10. Inspect and record the backlash at three or four points around the ring gear.
    - Hold the case stationary when checking backlash.
    - If the backlash varies more than 0.05 mm (0.002 in), inspect for the following conditions:
      - Burrs
      - A distorted case flange
      - Uneven bolting conditions
      - Foreign matter between the case and the ring gear
    - Gear backlash should be between 0.08–0.25 mm (0.003–0.010 in) with a preferred specification of 0.013–0.018 mm (0.005–0.007 in).
    - If the backlash is incorrect, adjust the sleeves as necessary. Maintain one notch preload on the side bearings. For example, if the right sleeve needs to be turned out one notch, turn in the left sleeve one notch.
    - In order to increase backlash, turn the left sleeve in and turn the right sleeve out the same amount. In order to decrease backlash, turn the right sleeve in and turn the left sleeve out the same amount.
  11. When the backlash is correct, mark the position of the sleeves in order to keep the sleeves in the same location.

## Differential Carrier Final Assembly (Except Bravada)

### Removal Procedure

1. Remove the 4 case bolts.
2. Remove the right carrier case half.
3. Clean the sealing surfaces on the carrier case halves. Remove all oil and grease using a chlorinated solvent, such as carburetor cleaner.

### Installation Procedure

#### Tools Required

- J 8092 Driver Handle
- J 23911 Seal Installer
- J 33791 Bushing Remover and Installer Set
- J 33799 Shift Cable Housing Seal Installer
- J 33842 Pilot Bearing Installer
- J 42211 Bearing Installer

1. Apply a bead of sealer (GM P/N 1052357 or equivalent) to one carrier half mounting surface.
2. Assemble the carrier halves.

**Notice:** Refer to *Fastener Notice* in Cautions and Notices.

3. Install the carrier halves assembly bolts.

#### Tighten

Tighten the bolts to 50 N·m (37 lb ft).

4. Ensure that the sleeves are positioned properly, as previously marked.
5. Install the bolts and lock tabs.

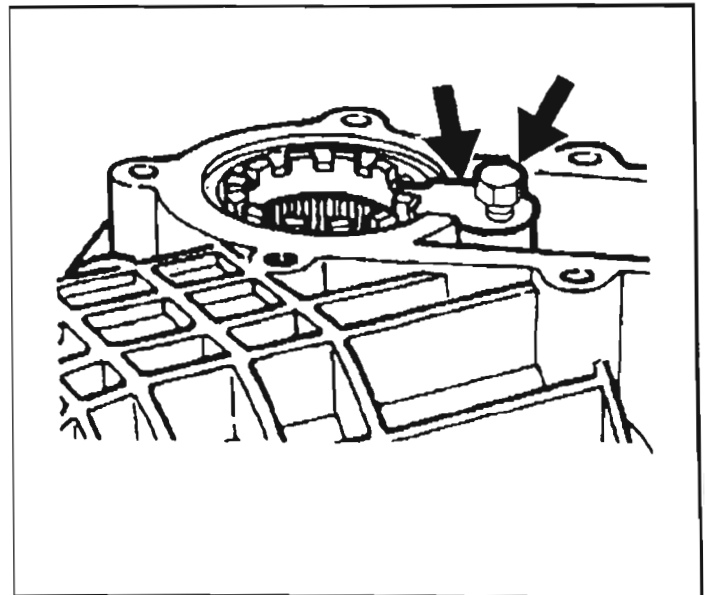
#### Tighten

Tighten the bolts to 8 N·m (71 lb in).

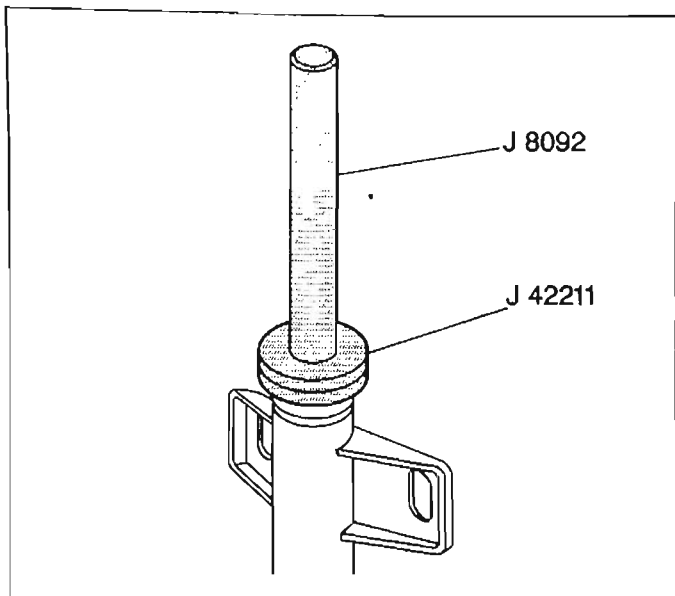
6. Clean all oil and grease from the left cover and seal assembly, the bolts and the carrier sealing surfaces using carburetor cleaner or equivalent.
7. Apply sealer (GM P/N 1052357 or equivalent) to the cover.
8. Install the left cover and seal assembly.

#### Tighten

Tighten the bolts to 25 N·m (18 lb ft).

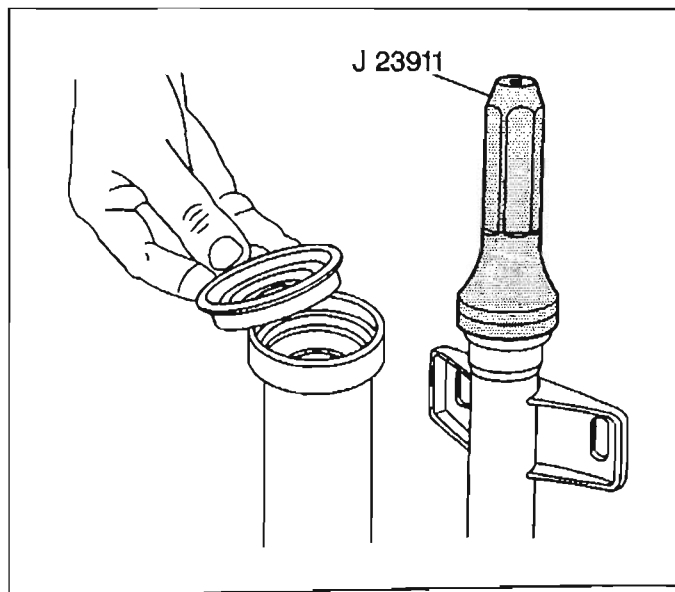


9. Install the bearing using the *J 42211* and the *J 8092*.



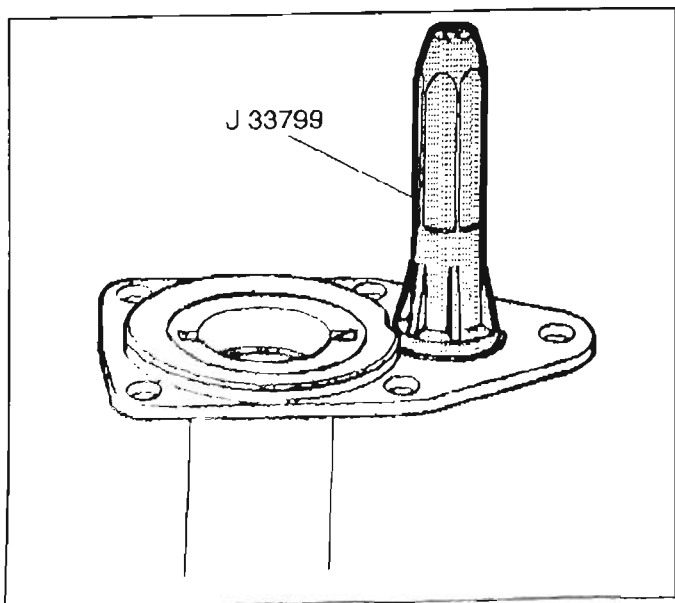
524680

10. Install the shaft seal using the *J 23911*.



321864

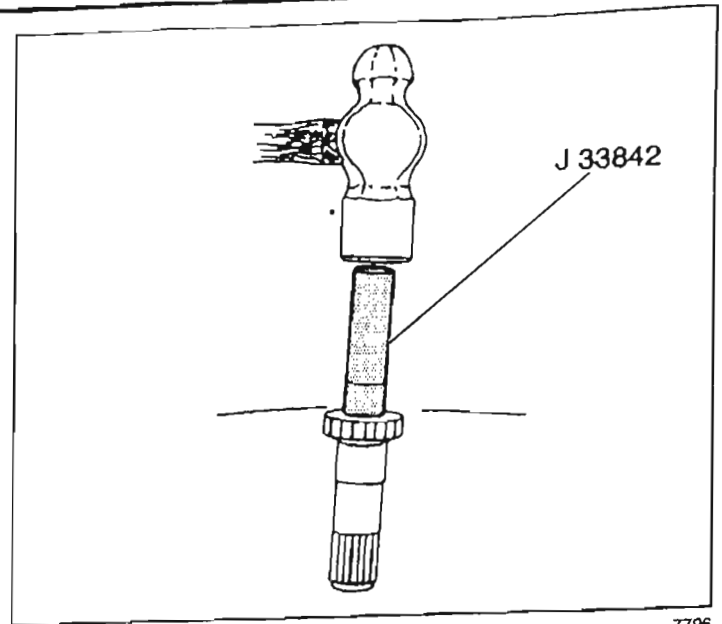
11. Install the shift housing seal using the *J 33799*.



7795

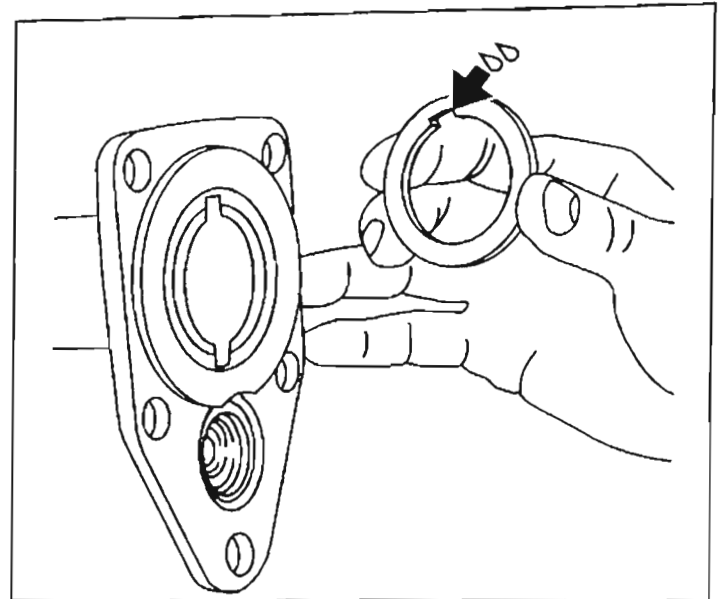
## Driveline/Axle

12. Install the clutch shaft pilot bearing using the *J 33842*.
13. Install the washer to the clutch shaft.
14. Install the clutch shaft to the carrier assembly.
15. Install the clutch sleeve.
16. Install the thrust washer using grease in order to secure.
17. Install the spring with the shift shaft and fork.



7796

18. Install the thrust washer using grease in order to secure. Align the notch and tab.
19. Install the inner axle shaft to the housing.
20. Install the clutch gear with the retaining ring. Tap into place.
  - 20.1. Remove all oil and grease from the housing flange to carrier gasket surfaces using carburetor cleaner or equivalent.
  - 20.2. Apply sealer (GM P/N 1052357 or equivalent) to the carrier.



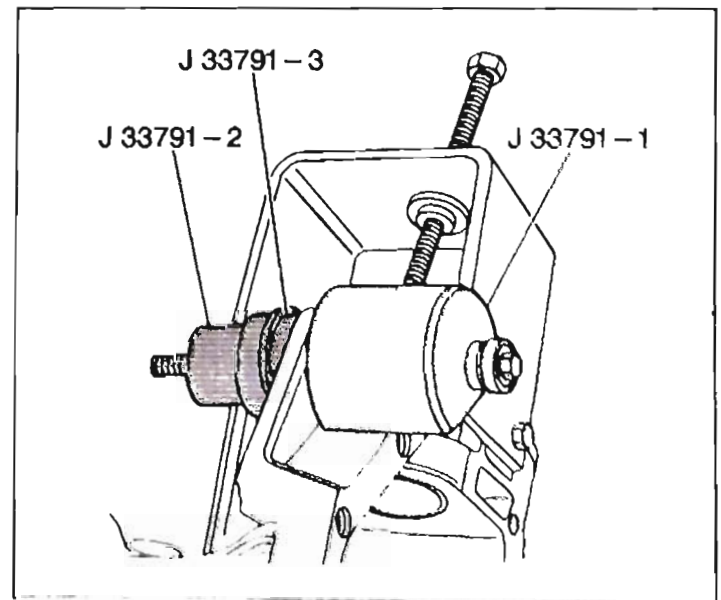
7797

21. Install the shaft and housing assembly to the carrier.
22. Install the two upper bolts finger-tight.
23. Install the shift cable housing and the remaining bolts.

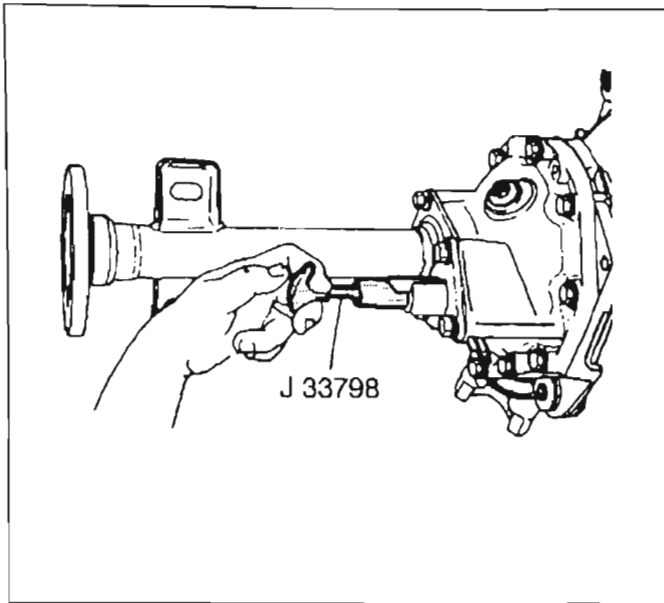
**Tighten**

Tighten the five bolts to 48 N·m (36 lb ft).

24. Install the bushings using the *J 33791 -1*, the *J 33791-2* and the *J 33791-3*.



3095



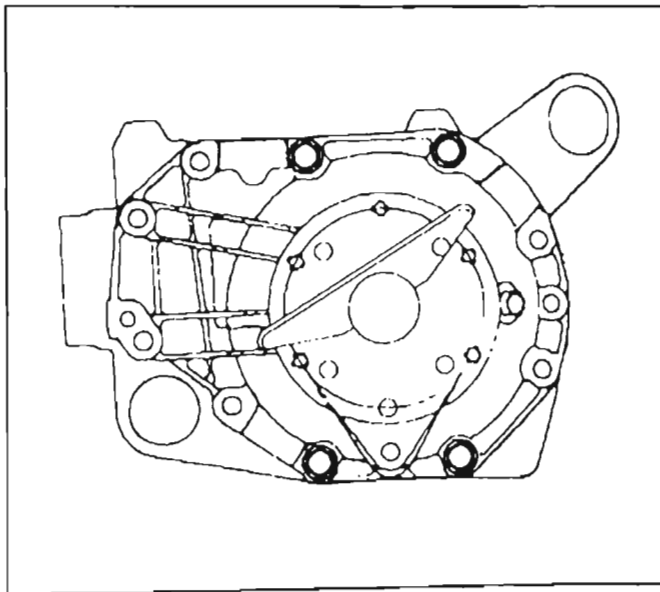
7798

### Inspection Procedure

#### Tools Required

*J 33798* Hub Engagement Tool

1. Inspect the operation of the shift mechanism. Insert the *J 33798* into the shift fork.
2. Turn the axle shaft while engaging and disengaging the shift mechanism with the tool.
3. The mechanism should operate smoothly. If not, remove the tube. Inspect for damaged or improperly installed parts.



9352

### Differential Carrier Final Assembly (Bravada)

#### Removal Procedure

1. Remove the four case bolts.
2. Remove the right carrier case half.
3. Clean the sealing surfaces on the carrier case halves. Remove all the oil and grease. Use a chlorinated solvent, such as carburetor cleaner.

### Installation Procedure

#### Tools Required

- *J 8092* Driver Handle
- *J 23911* Seal Installer
- *J 33791* Bushing Remover and Installer Set
- *J 42211* Bearing Installer

1. Apply a bead of sealer (GM P/N 1052357 or equivalent) to one carrier half mounting surface. Follow the sealer manufacturer's instructions when applying the sealer.
2. Assemble the carrier halves.

**Notice:** Refer to *Fastener Notice* in Cautions and Notices.

3. Install the carrier halves assembly bolts.

**Tighten**

Tighten the bolts to 50 N·m (37 lb ft).

4. Ensure that the sleeves are positioned properly, as previously marked.
5. Install the bolts and the lock tabs.

**Tighten**

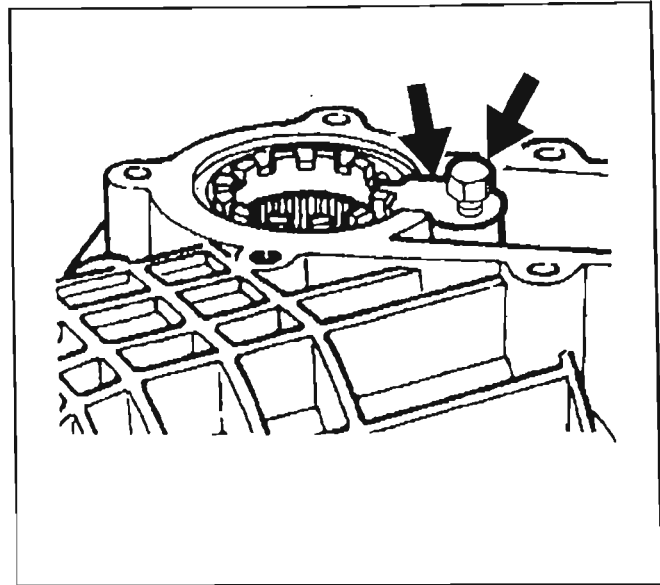
Tighten the bolts to 8 N·m (71 lb in).

6. Clean all the oil and grease from the left cover and seal assembly, the bolts and the carrier sealing surfaces. Use carburetor cleaner or equivalent.
7. Apply sealer (GM P/N 1052357 or equivalent) to the cover.
8. Install the left cover and seal assembly.

**Tighten**

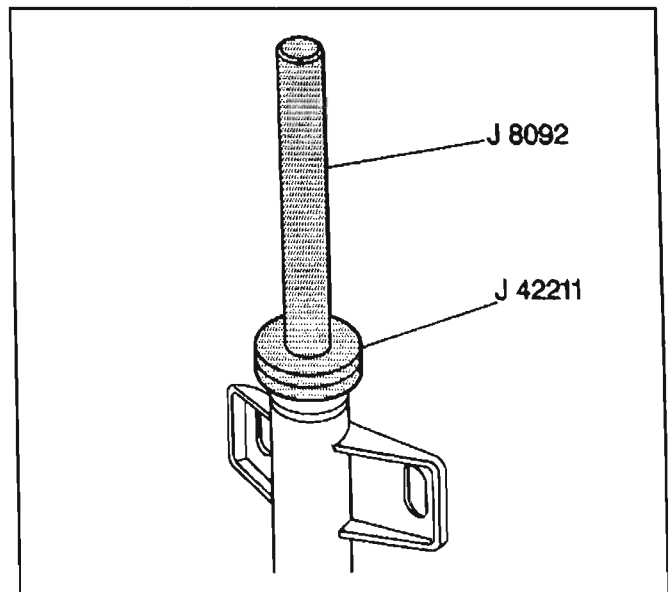
Tighten the bolts to 25 N·m (18 lb ft).

9. Install the left output shaft. Tap into place.

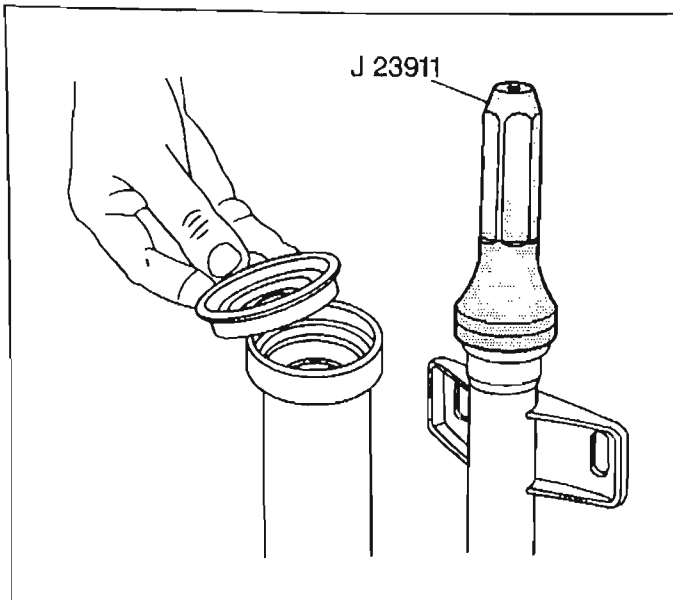


9031

10. Install the bearing. Use the *J 42211* and the *J 8092*.



524680



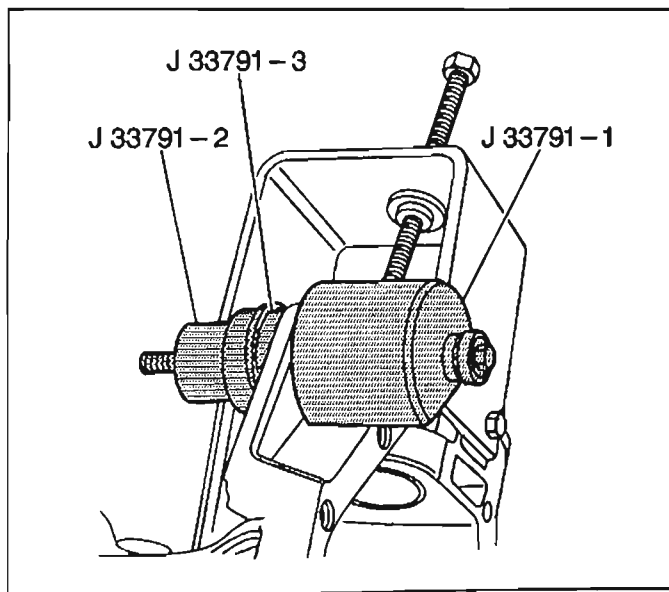
321864

11. Install the seal. Use the *J 23911*.
12. Install the inner axle shaft housing to the carrier.
13. Install the inner axle shaft housing to carrier bolts.

**Tighten**

Tighten the bolts to 48 N·m (36 lb ft).

14. Install the axle shaft. Tap into place using a soft-faced hammer.



3095

15. Install the case bushings. Use the *J 33791-1*, *J 33791-2*, and *J 33791-3*.

## Description and Operation

### Front Drive Axle Description

The front axle on automatic four-wheel drive models (Bravada) uses a conventional ring and pinion gear set to transmit the driving force from the engine to the wheels. The axle is designed to remain in constant four-wheel drive operation. The axle has no disconnect feature.

The front driving axle on selectable four-wheel drive models (Chevrolet and GMC) uses a central disconnect type front axle/transfer case system. This allows shifting in and out of four-wheel drive when the vehicle is moving under most driving conditions.

The differential allows the wheels to turn at different rates of speed while the front axle continues to transmit the driving force. This prevents tire scuffing and premature wear on internal axle parts.

Two tapered roller bearings support the differential case in the axle housing. The differential and ring gear use threaded adjusters and are located in relationship to the pinion. The ring gear bolts to the differential case using left-hand thread bolts.

Two tapered roller bearings support the pinion gear. The pinion depth is set by a shim pack between the gear end of the pinion and the roller bearing pressed onto the pinion. Pinion bearing preload is set by crushing a collapsible spacer between the pinion bearings in the axle housing.

The axle identification code is stamped on the top left half of the carrier case along the edge of the machined face.

The wheel drive shafts are completely flexible. These consist of inner and outer constant velocity (CV) joints that are connected to an axle shaft. The inner CV joint is a tripod design that is completely flexible, and can also move in and out. The outer CV joint is a Rzeppa™ design that is flexible, but cannot move in and out.

### Special Tools and Equipment

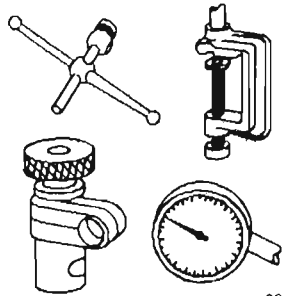
Illustration	Tool Number/Description
 <p style="text-align: right;">2014</p>	<p>J 8001 Dial Indicator Set</p>


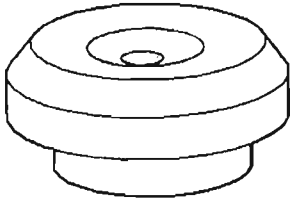
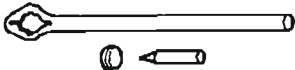
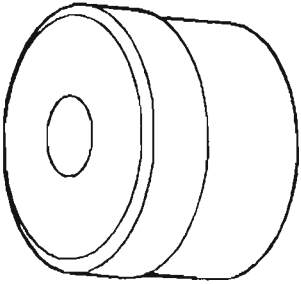
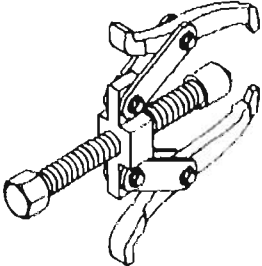
Illustration	Tool Number/Description
 <p style="text-align: right;">2015</p>	<p>J 8092 Driver Handle</p>
 <p style="text-align: right;">5322</p>	<p>J 8107-2 Differential Side Bearing Remover</p>
 <p style="text-align: right;">1507</p>	<p>J 8614-01 Pinion Yoke Holder</p>
 <p style="text-align: right;">5713</p>	<p>J 21551 Output Shaft Bearing Remover</p>
 <p style="text-align: right;">5114</p>	<p>J 22888-20 Differential Side Bearing Puller</p>

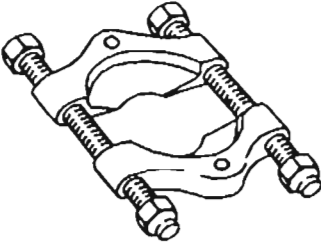
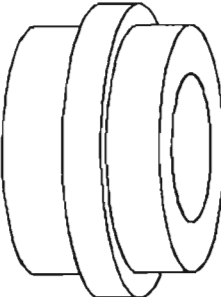
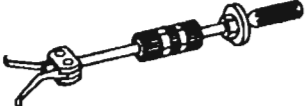
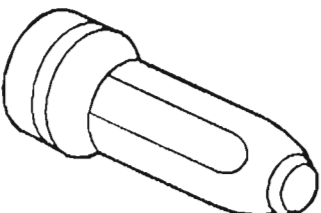
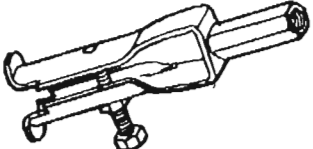
Illustration	Tool Number/Description
 <p>162970</p>	<p>J 22912-01 Pinion Bearing Remover</p>
 <p>5720</p>	<p>J 23423-A Side Bearing Cup Installer</p>
 <p>183081</p>	<p>J 23907 Slide Hammer</p>
 <p>1509</p>	<p>J 23911 Seal Installer</p>
 <p>67531</p>	<p>J 29369-1 Universal Bearing Remover</p>

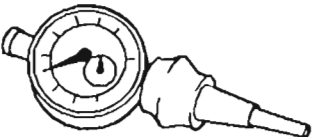
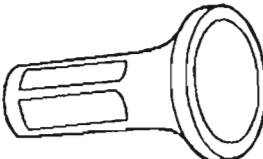
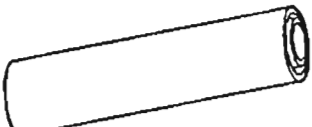
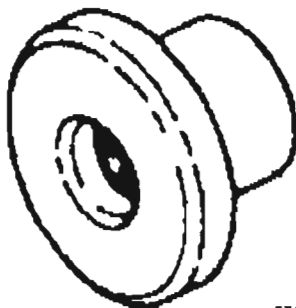
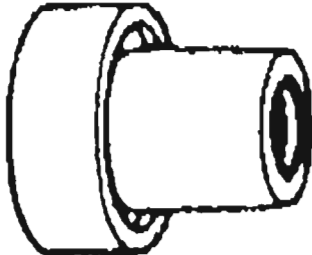
Illustration	Tool Number/Description
 <p>5714</p>	<p>J 29763 Dial Indicator</p>
 <p>142251</p>	<p>J 33782 Pinion Oil Seal Installer</p>
 <p>5715</p>	<p>J 33785 Pinion Bearing Installer</p>
 <p>5718</p>	<p>J 33788 Output Shaft Bearing Installer</p>
 <p>5718</p>	<p>J 33790 Differential Side Bearing Installer</p>

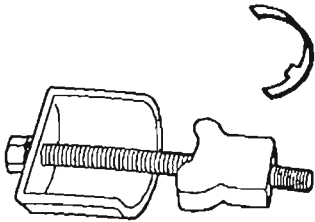
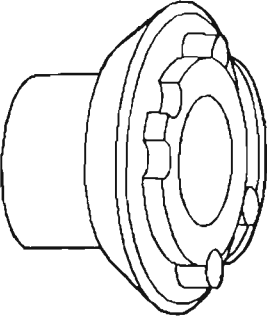
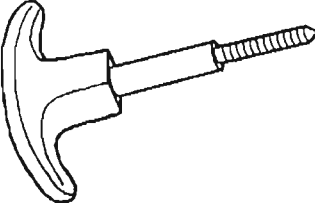
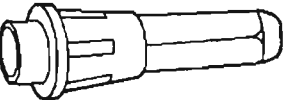
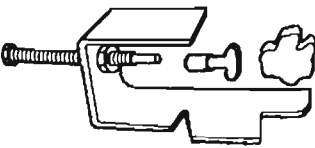

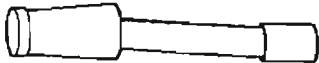
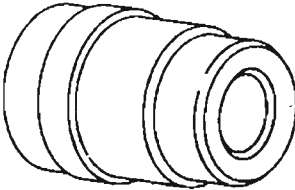
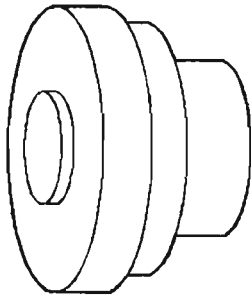
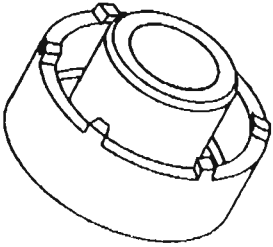
Illustration	Tool Number/Description
 <p data-bbox="386 432 423 453">5619</p>	<p data-bbox="483 254 737 344">J 33791 Bushings Remover and Installer Set</p>
 <p data-bbox="386 774 423 795">5719</p>	<p data-bbox="483 596 737 686">J 33792 Side Bearing Adjuster Socket</p>
 <p data-bbox="386 1117 423 1138">5620</p>	<p data-bbox="483 947 737 1016">J 33798 Hub Engagement Tool</p>
 <p data-bbox="370 1459 423 1480">142243</p>	<p data-bbox="472 1268 753 1358">J 33799 Shift Cable Housing Seal Installer</p>
 <p data-bbox="386 1793 423 1814">5721</p>	<p data-bbox="483 1610 737 1701">J 33837 Pinion Bearing Cup Remover and Installer</p>

Illustration	Tool Number/Description
 <p data-bbox="1130 443 1174 464">5622</p>	<p data-bbox="1230 275 1484 344">J 33842 Pilot Bearing Installer</p>
 <p data-bbox="1130 785 1174 806">9099</p>	<p data-bbox="1224 611 1484 680">J 34011 Pilot Bearing Remover</p>
 <p data-bbox="1110 1117 1174 1138">536307</p>	<p data-bbox="1230 938 1484 1029">J 36611 Output Shaft Bearing Remover</p>
 <p data-bbox="1110 1459 1174 1480">161438</p>	<p data-bbox="1256 1283 1451 1352">J 42211 Bearing Installer</p>
 <p data-bbox="1110 1793 1174 1814">534239</p>	<p data-bbox="1230 1610 1484 1701">J 42213 Side Bearing Adjuster Socket</p>