

## Wheel Drive Shaft Inner Joint and Boot Replacement

### Disassembly Procedure

#### Tools Required

J 8059 Snap Ring Pliers

1. Remove the clamps from the boot with a pair of side cutters.

- Important:** Do not damage the tripot housing (1).
2. Use a hand grinder to cut through the swage ring.
  3. Remove the tripot housing (1) and the tripot trilobal bushing (2) from the halfshaft bar (5).
  4. Wipe the grease off of the tripot assembly roller bearings and the housing (1).
  5. Thoroughly degrease the housing (1) and the tripot trilobal bushing (2).
  6. Use 320 grit 3M cloth (or equivalent) to remove any evident corrosion in the transmission sealing surface.
  7. Allow the housing (1) and the tripot trilobal bushing (2) to dry prior to assembly.

**Important:** Handle the tripot spider assembly (1) with care. Tripot balls and needle rollers may separate from the spider trunnion if the tripot balls and needle rollers are not handled carefully.

8. Compress the tripot boot (4) onto the halfshaft bar (3), away from the spider assembly (1).

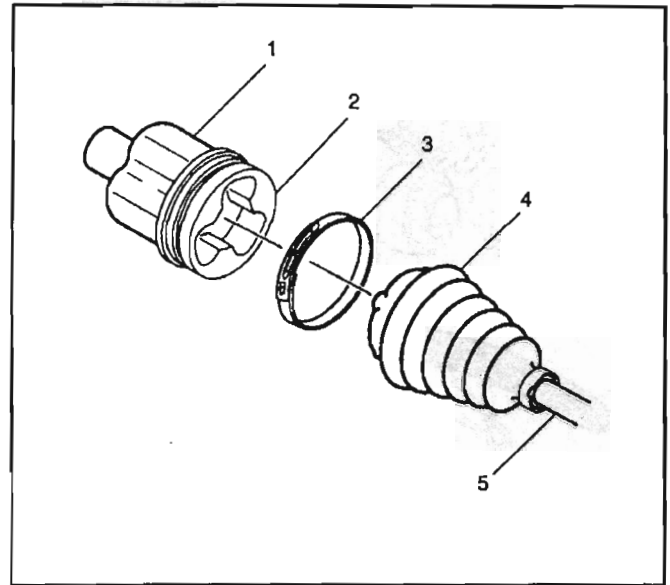

243181

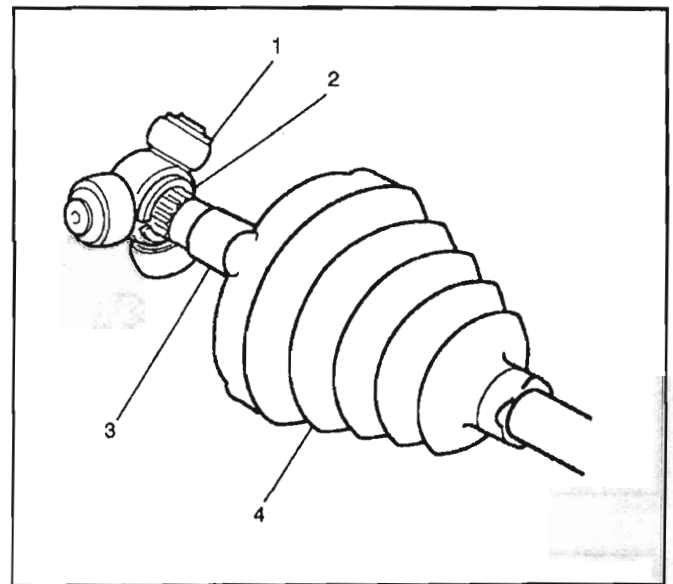

244513

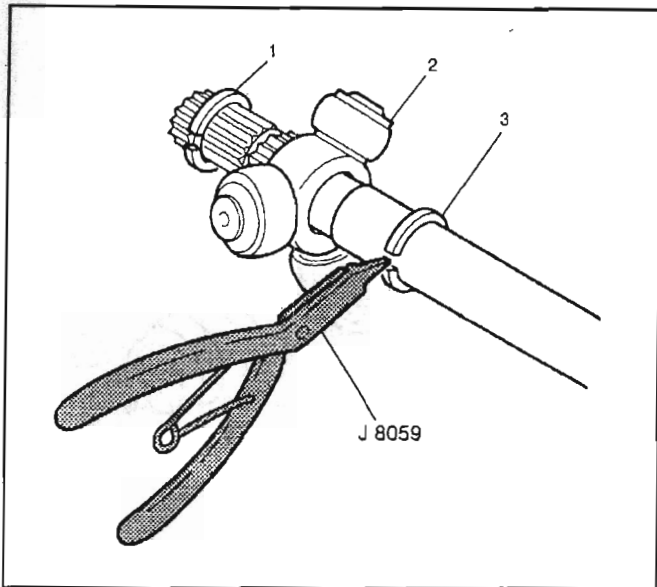

244491

9. Spread the spacer rings using *J 8059* (or equivalent) to remove the spider assembly.

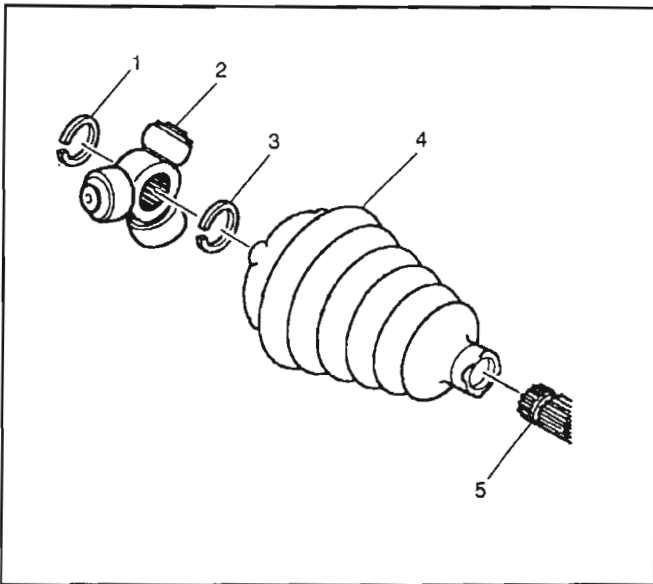

233581

10. Remove the following items:

- The spacer ring (1)
- The spider assembly (2)
- The second spacer ring (3)
- The tripot boot (4)

11. Clean the halfshaft bar. Use a wire brush to remove any rust in the boot mounting area (grooves).

12. Inspect the following items:

- The needle rollers
- The needle bearings
- The trunnion

13. Check the tripot housing for unusual wear, cracks, or other damage.

14. Replace any damaged parts.

### Assembly Procedure

#### Tools Required

- *J 41048* Swage Clamp Tool
- *J 35566* Large Seal Retaining Clamp Tool

1. Slide the new small swage clamp (2) and the boot (1) to the proper position (3) on the halfshaft bar.

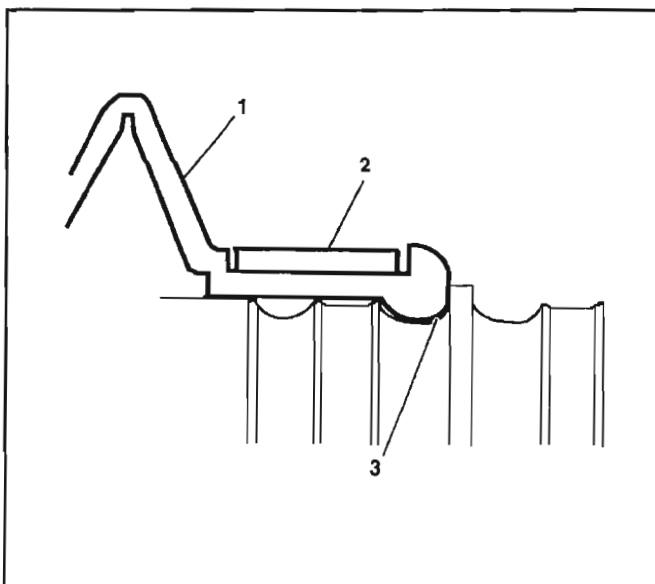

386688

Driv  
2.  
3.  
4.  
5. A  
6. Pi  
br  
7. Cl  
th  
8. In  
9. Ti  
10. Al  
.  
.  
.  
11. Lc

2. Install the new swage clamp onto the neck of the boot. Do not swage.
3. Position the neck of the boot in the boot groove on the halfshaft bar.
4. In order to swage the swage clamp, position the inboard end (1) of the halfshaft assembly in *J 41048*.

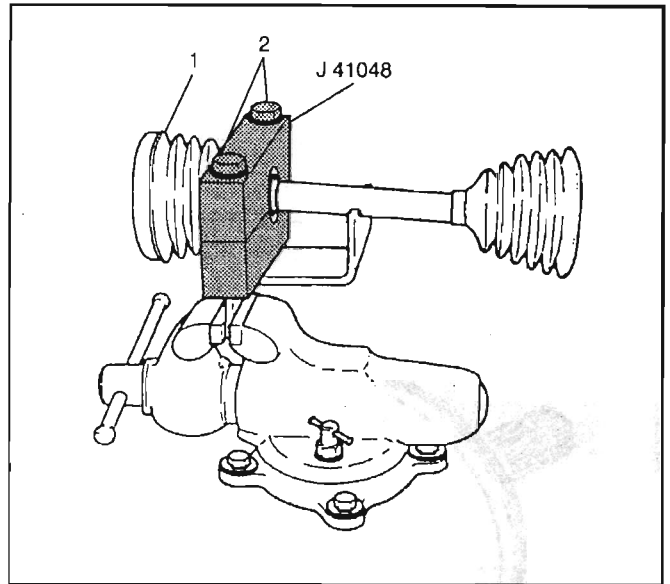

221917

5. Align the swage clamp (2) within *J 41048*.

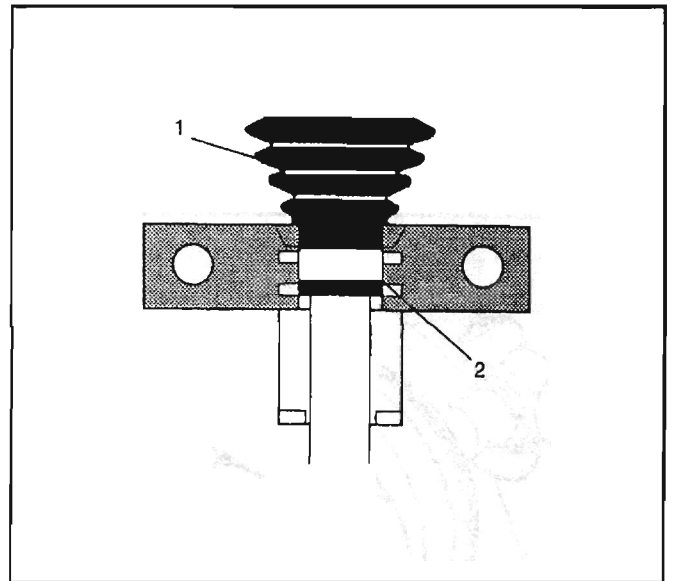

221918

6. Place the top half of the *J 41048* on the bottom half.
7. Check to make sure there are no pinch points on the boot before proceeding.
8. Insert the bolts (2).
9. Tighten the bolts (2) by hand until snug.
10. Align the following items:
  - The boot
  - The housing
  - The swage clamp

**Tighten**

Each bolt 180 degrees at a time, using a ratchet wrench. Alternate between each bolt until both sides are bottomed.

11. Loosen the bolts.

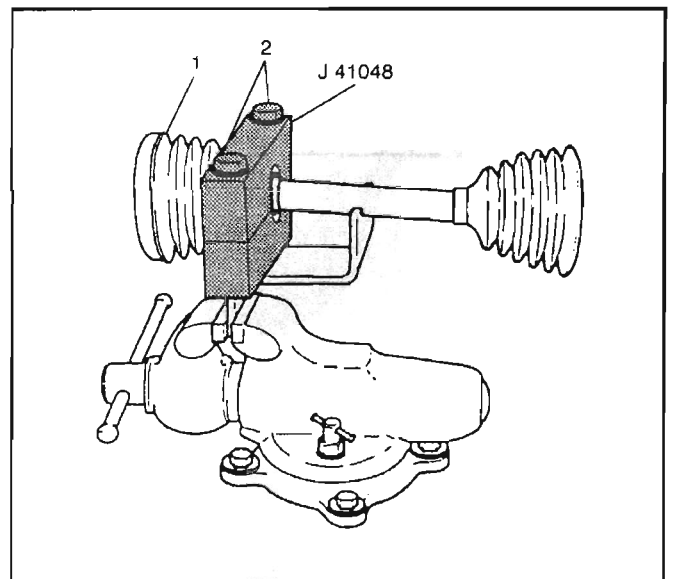

221917

12. Separate the dies.

**Important:** If deformities exist in the swage clamp, place the swage clamp back into *J 41048*. Ensure the swage clamp covers the whole swaging area. Re-swage the swage clamp.

13. Check the swage clamp for any "lip" deformities.

**Important:** Assemble the joint with the convolute retainer in the correct position. Assemble the joint to meet the specified dimension to avoid boot damage.

14. Install the convolute retainer over the boot capturing four convolutions.

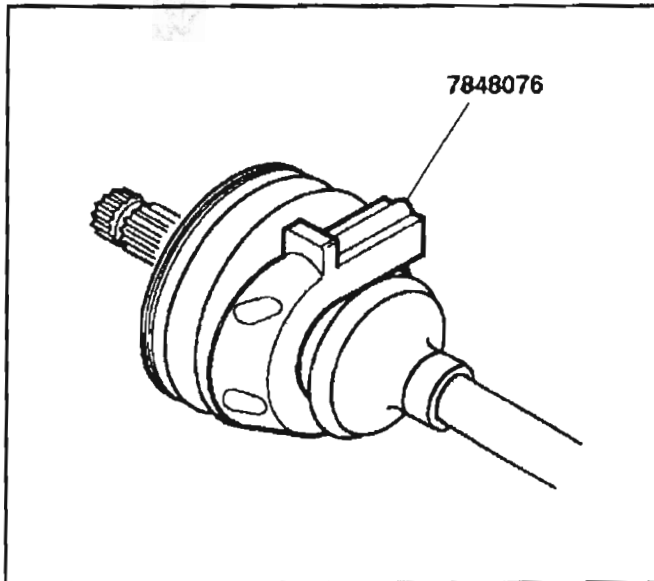

340715

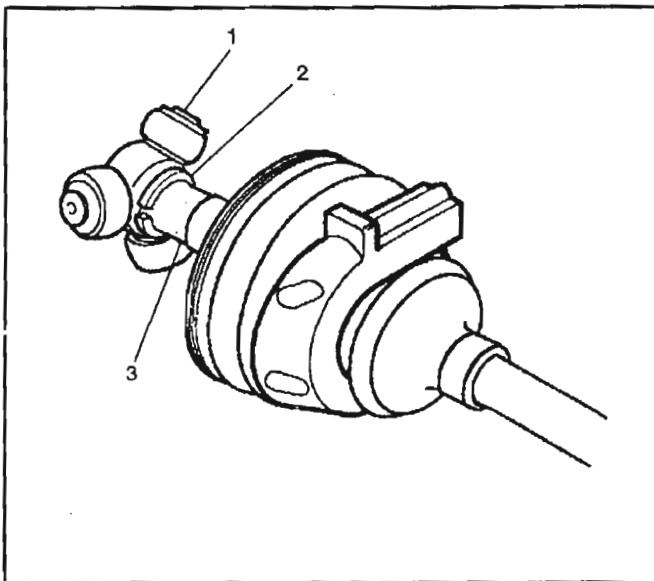

340719

**Important:** Ensure that the rings are fully seated.

15. Install the spacer ring (2) and spider assembly (1) onto the halfshaft bar (3).

16. Install the other spacer ring in the groove at the end of the halfshaft bar. Ensure that the rings are fully seated.

17. Pack the boot and housing with the grease supplied in the kit. The amount of grease supplied in this kit has been pre-measured for this application.
18. Place the large retaining clamp (2) on the boot.
19. Place the housing (1) and the tripot trilobal bushing over the spider assembly (3).
20. Install the boot onto the tripot trilobal bushing.

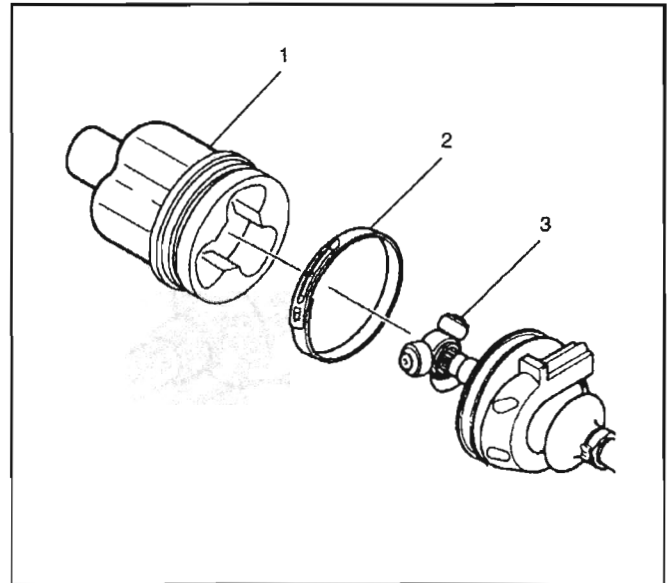

243202

21. Check the inboard stroke position.

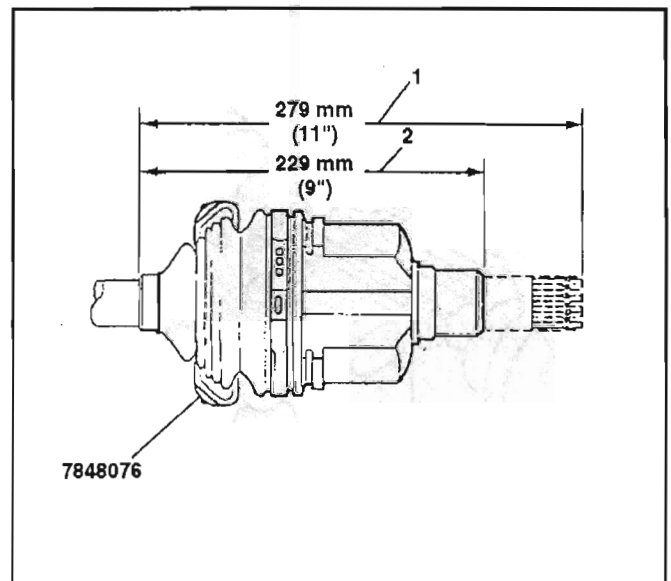

244519

22. Secure the large retaining clamp (2) and the boot (3) to the housing (1) using J 35566.

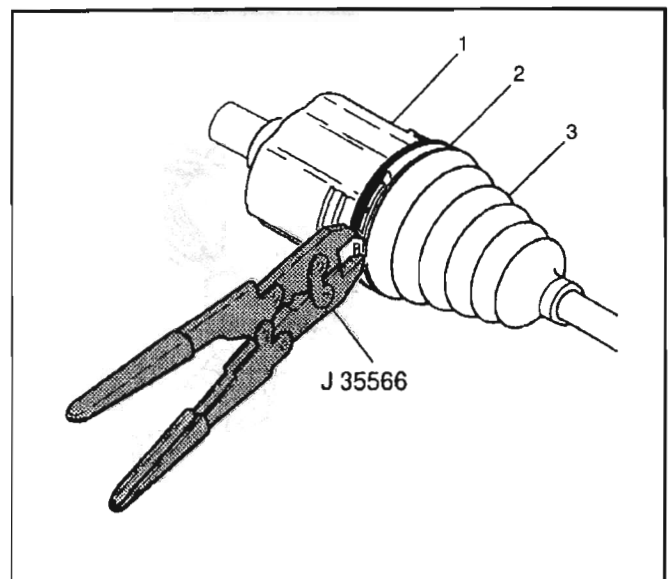

243212

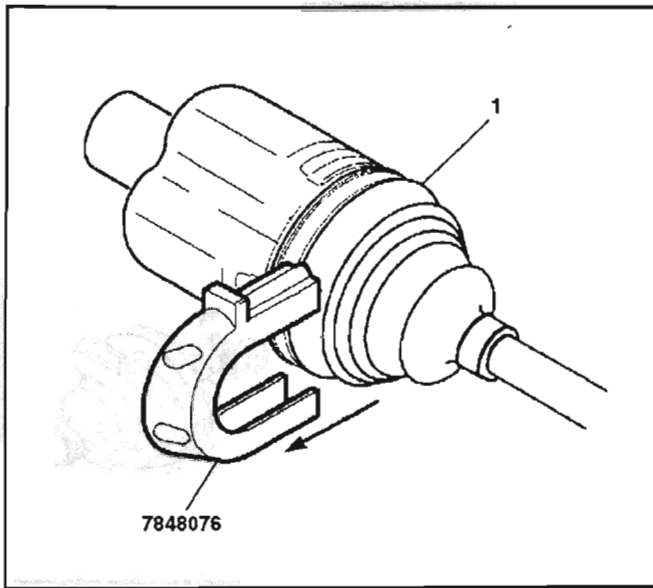

340720

23. Remove the convolute retainer from the boot (1).

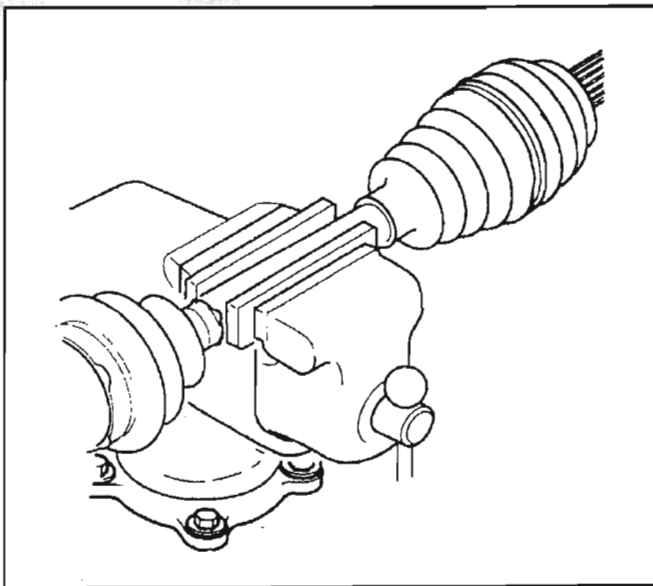

243155

## Wheel Drive Shaft Outer Joint and Boot Replacement

### Disassembly Procedure

#### Tools Required

*J 8059* Snap Ring Pliers

1. Place the halfshaft in a vise.
2. Place protective covers over the vise jaws.

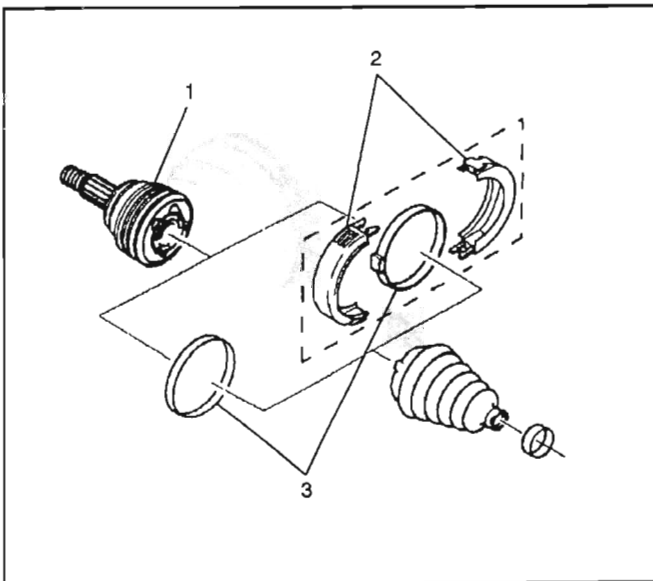

244506

3. Remove the boot clamp protectors (2) (if used) from the outer CV joint (1).
4. Cut the clamps (3) from the boot with a pair of side cutters.
5. Use a hand grinder to cut through the swage ring. Do not damage the outer race.
6. Compress the boot on the halfshaft and away from the CV joint outer race (1).
7. Wipe all grease away from the face of the CV joint.

- (1).
8. Find the halfshaft retaining snap ring (3), which is located in the inner race (2).
  9. Spread the snap ring ears apart using J 8059 (or equivalent).
  10. Pull the CV joint from the halfshaft (4).
  11. Discard the old boot.

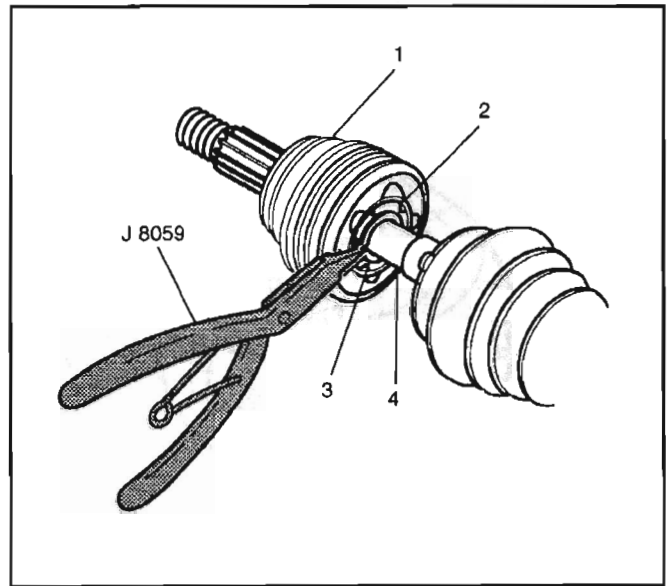

243160

12. Place a brass drift against the cage (1).
13. Tap gently on the brass drift in order to tilt the cage.
14. Remove the first ball (2) when the cage tilts.
15. Repeat the previous step to remove all of the balls.

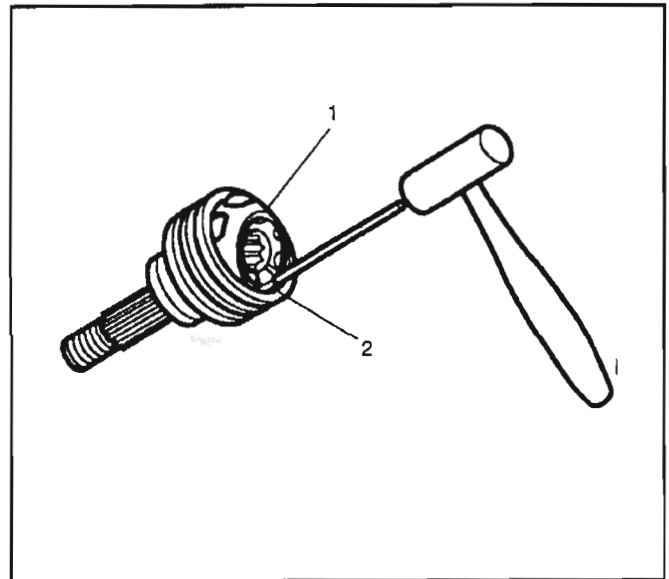

211933

16. Pivot the cage (4) and the inner race 90 degrees to the centerline of the outer race (1). At the same time, align the cage windows (3) with the lands of the outer race (2).
17. Lift out the cage (4) and the inner race.

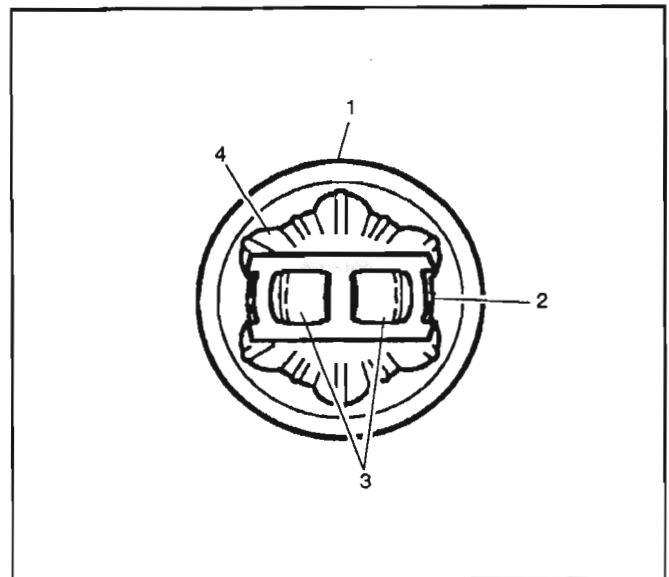

214946

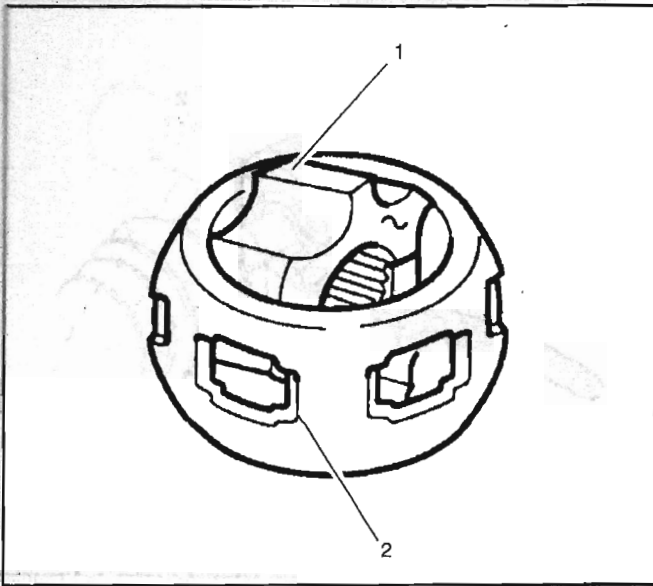

214947

18. Remove the inner race from the cage by rotating the inner race upward.
19. Thoroughly degrease all of the CV joint parts.
20. Check the outer CV joint assembly for unusual wear, cracks, or other damage. Replace any damaged parts.
21. Clean the halfshaft bar. Use a wire brush to remove any rust in the boot mounting area (grooves).

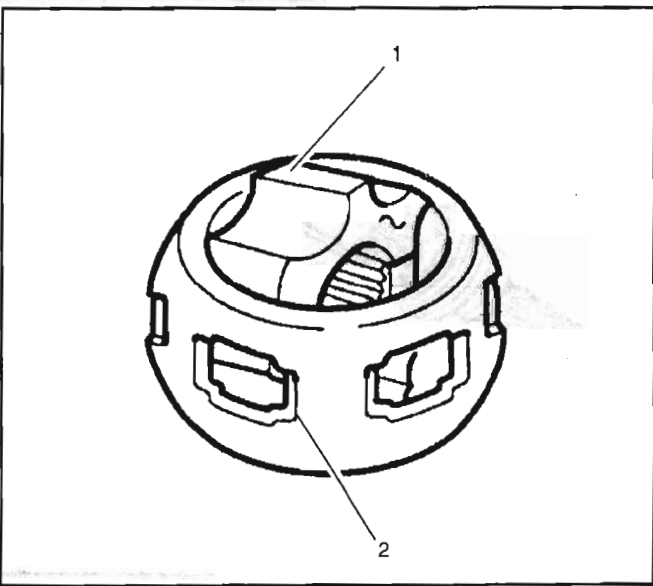

214947

**Assembly Procedure**

**Tools Required**

- J 35910 Seal Clamp Tool
- J 41048 Swage Clamp Tool

**Important:** Replace the joint assembly if necessary.

1. Inspect all of the parts for unusual wear, cracks, or other damage.
2. Put a light coat of the recommended grease on the inner and the outer race grooves.
3. Insert the inner race into the cage by rotating the inner race downward.
4. Hold the inner race (1) at 90 degrees to the centerline of the cage.
5. Align the lands of the inner race (2) with the windows of the cage (3).
6. Rotate the inner race downward to insert the inner race into the cage.
7. Insert the cage (4) and inner race into the boot.

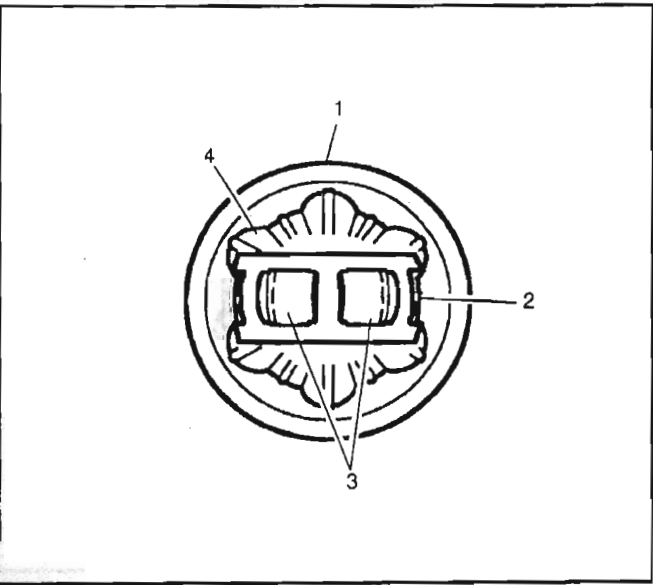

214946

2. Pack 1 with the grease for this joint.

3. Place CV joint on the axle.

4. Place the joint on the axle.

5. Position the joint on the axle.

6. Position the joint on the axle.

8. Place a brass drift against the cage (1).
9. Tap gently on the brass drift in order to tilt the cage (1).
10. Install the first ball (2) when the cage tilts.
11. Repeat previous step to reinstall all of the balls.

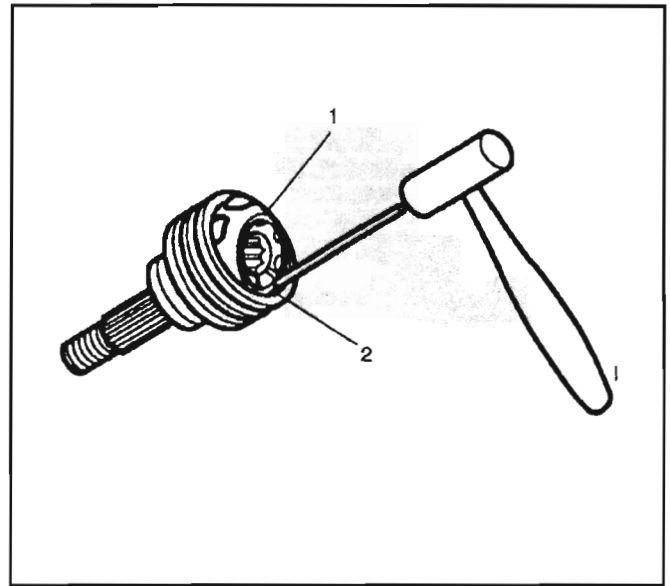

211933

12. Pack the CV joint boot and the CV joint assembly with the grease supplied in the kit. The amount of grease supplied in this kit has been pre-measured for this application.
13. Place the new small swage clamp (2) onto the CV joint boot (1).
14. Place the large retaining clamp on the boot (1).
15. Position the small end of the CV joint boot (1) into the joint boot groove (3) on the halfshaft bar.

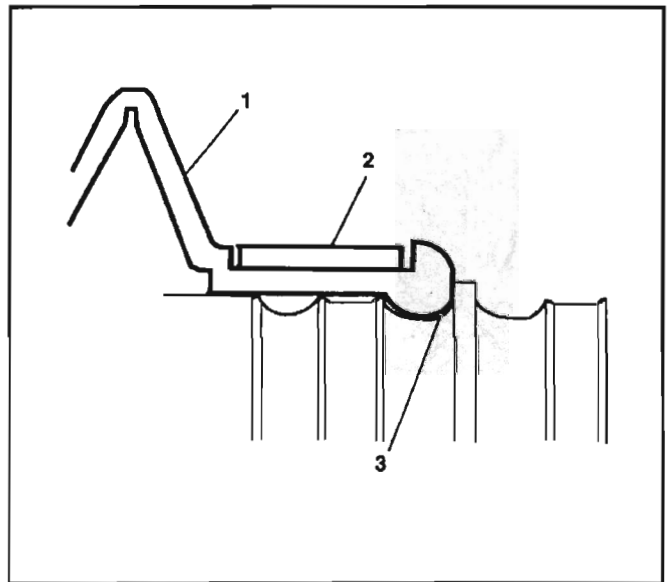

386688

16. Position the outboard end of the halfshaft assembly (1) in J 41048.

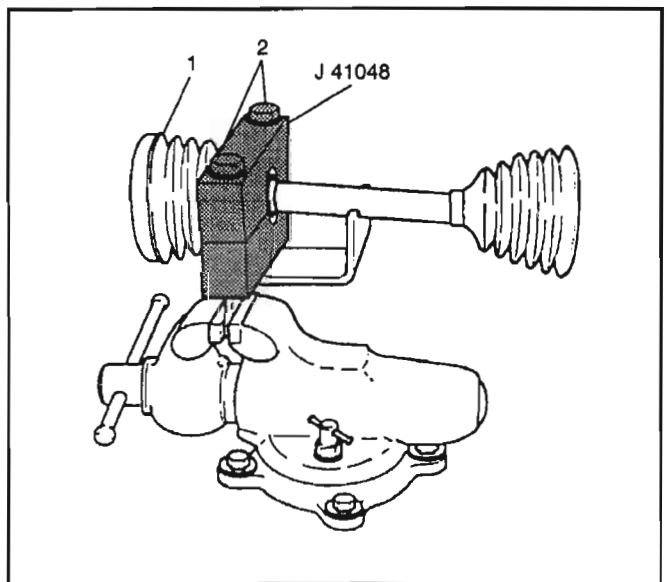

221917

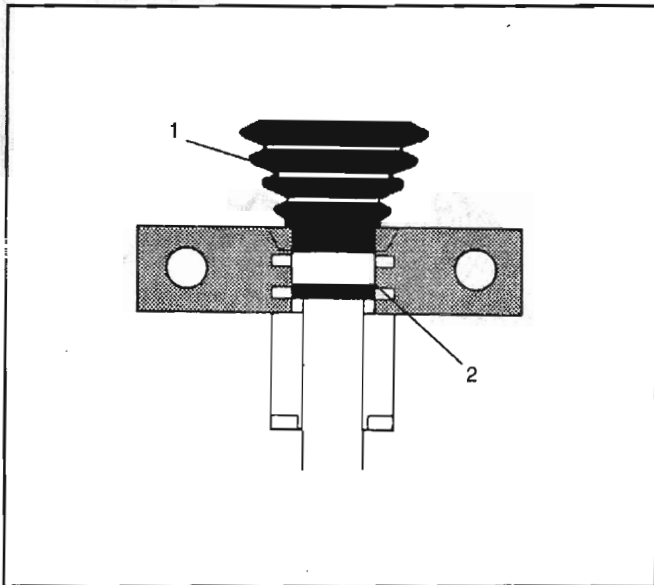

221918

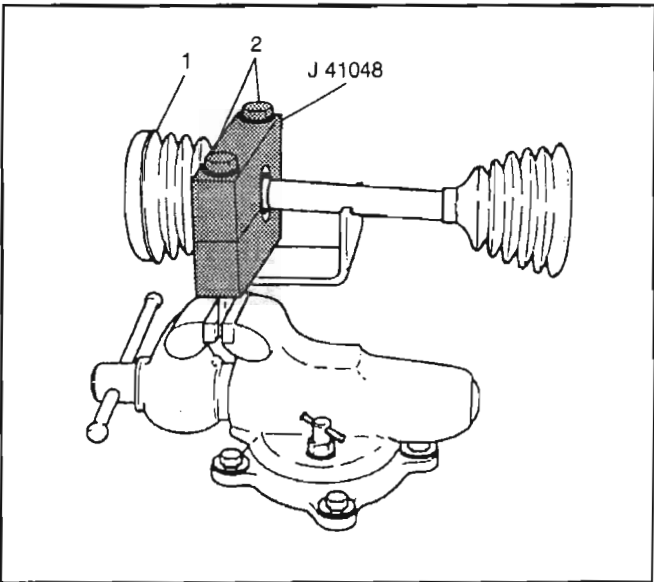

221917

17. Align the swage clamp (2) within *J 41048*.

18. Place the top half of the *J 41048* on the bottom half.

19. Check to make sure there are no pinch points on the boot before proceeding with procedures.

20. Insert the bolts (2). Tighten the bolts (2) by hand until snug.

**Notice:** Refer to *Fastener Notice* in Cautions and Notices.

21. Align the following items:

- The boot
- The housing
- The swage clamp

**Tighten**

Each bolt 180 degrees at a time, using a ratchet wrench. Alternate between each bolt until both sides are bottomed.

22. Loosen the bolts.

23. Separate the dies.

24. Check the swage clamp for any "lip" deformities. If the deformities exist, place the swage clamp back into the *J 41048*.

**Important:** Ensure that the retaining ring side of the CV joint inner race faces the halfshaft bar (1) before installation.

25. Place the retaining snap ring into the CV joint inner race.

**Important:** The retaining snap ring inside of the inner race engages in the halfshaft bar groove with a click when the CV joint is in the proper position.

26. Slide the CV joint (2) onto the halfshaft bar (1).  
27. Pull on the CV joint (2) to verify engagement.

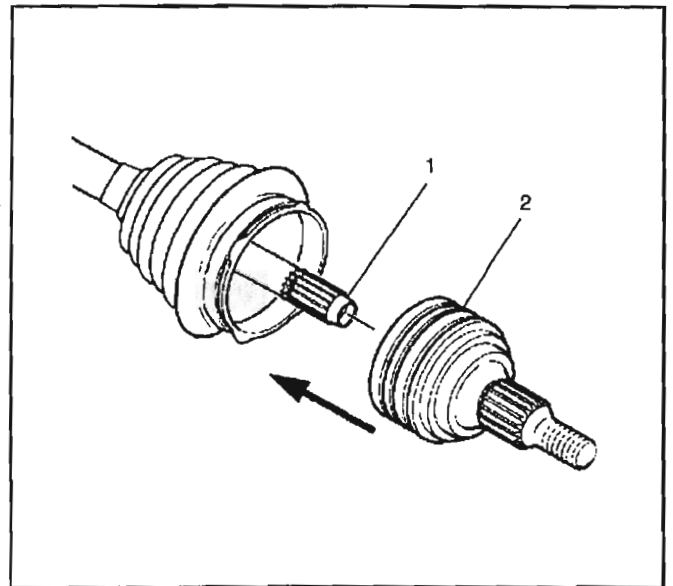

340723

28. Slide the large diameter of the CV joint boot (1), with the large retaining ring (2) in place, over the outside edge of the CV joint outer race (3).  
29. Position the lip of the CV joint boot (1) into the groove on the CV joint outer race (3).  
30. Manipulate the CV joint boot (1) to remove any excess air.

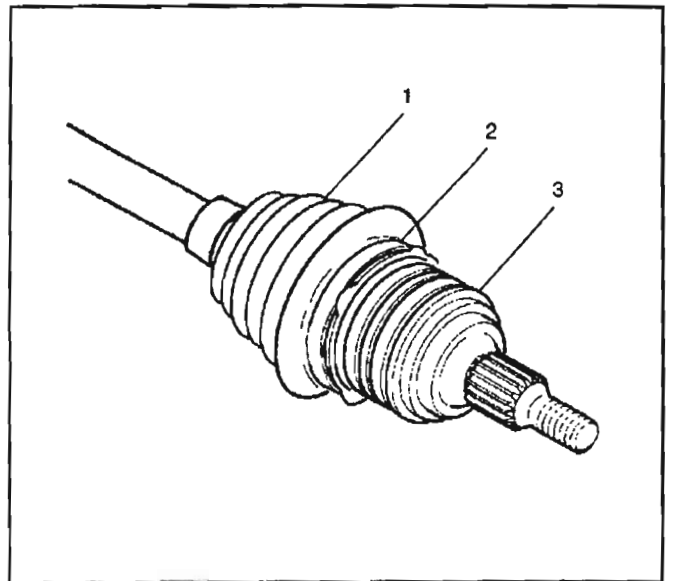

340734

31. Secure the large retaining clamp (1) this replaces the swage ring and the boot to the housing with *J 35910* (or equivalent), a breaker bar (3), and a torque wrench (2).

#### Tighten

Torque the large retaining clamp (1) to 176 N·m (130 lb ft).

32. Check the gap dimension on the clamp ear.  
33. Install the boot clamp protectors (if used) over the large retaining clamp.

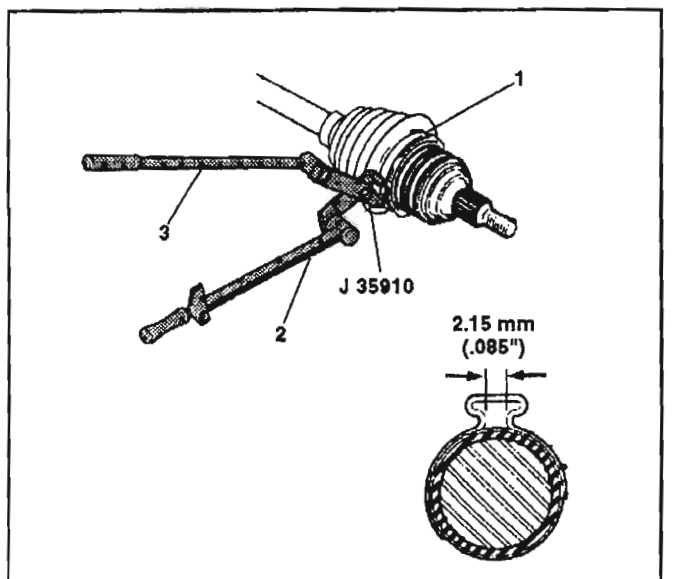

244528

Special Tools and Equipment

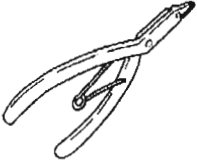
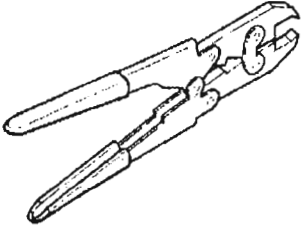
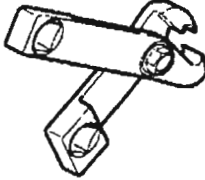
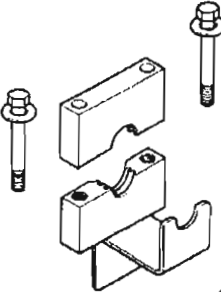
Illustration	Tool Number/ Description
 <p data-bbox="310 499 370 516">221884</p>	<p data-bbox="451 327 634 390">J 8059 Snap Ring Pliers</p>
 <p data-bbox="310 831 370 848">243221</p>	<p data-bbox="407 659 678 722">J 35566 Earless Seal Clamp Tool</p>

Illustration	Tool Number/ Description
 <p data-bbox="1024 499 1084 516">221882</p>	<p data-bbox="1166 327 1349 390">J 35910 Seal Clamp Tool</p>
 <p data-bbox="1024 831 1084 848">221886</p>	<p data-bbox="1154 659 1365 722">J 41048 Swage Clamp Tool</p>

D  
F  
S