

Suspension Bottoms

Step	Action	Value(s)	Yes	No
DEFINITION: A loud bang that can usually be felt and heard when the vehicle is driven over bumps. This condition is commonly noticed when the vehicle trim height is too low.				
1	Road test the vehicle in order to verify the customer complaint. Ensure that the customer complaint is the suspension bottoming and not only a noise. Does the suspension bottom abnormally easy when the vehicle is driven over bumps?	—	Go to Step 2	System OK
2	1. Check for vehicle overloading. Refer to <i>Tire Placard</i> in General Information. 2. If necessary, remove the excess weight from the vehicle. 3. Road test the vehicle in order to verify the customer complaint. Does the suspension bottom abnormally easy when the vehicle is driven over bumps?	—	Go to Step 3	System OK
3	Inspect the vehicle trim height. Refer to <i>Trim Height Inspection Procedure</i> . Repair as necessary. Has the inspection/repair been performed?	—	Go to Step 1	System OK

Trim Height Inspection Procedure

Z Height

Trim height is a predetermined measurement relating to vehicle ride height. Incorrect trim heights may cause symptoms similar to alignment problems. Check the trim heights when you diagnose steering or vibration complaints.

The Z dimension measurement determines the proper ride height for the front end. The Z dimension is different for RWD vehicles and 4WD or A4WD vehicles. The 4WD and A4WD vehicles have different points of measurement to determine Z height. Use the torsion bar adjusting arm in order to adjust Z height. RWD vehicles have no adjustment and could require replacement of suspension components.

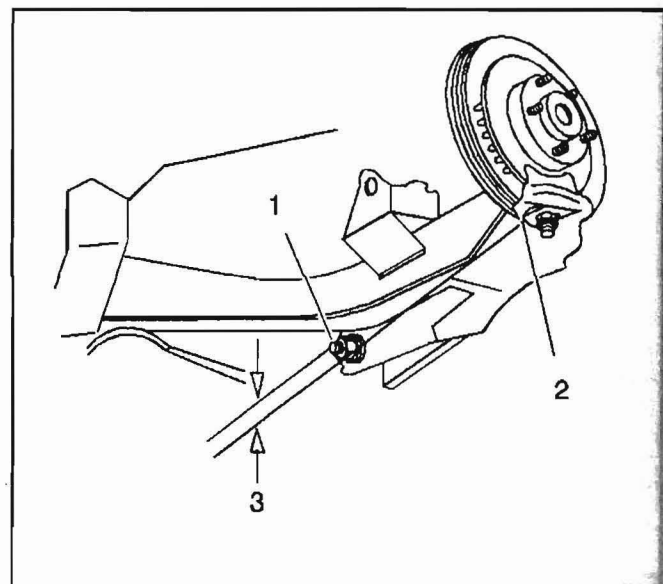

On 4WD and A4WD vehicles, measure Z height from the center line of the pivot bolt (1) down to the lowest inboard edge of the steering knuckle (2).

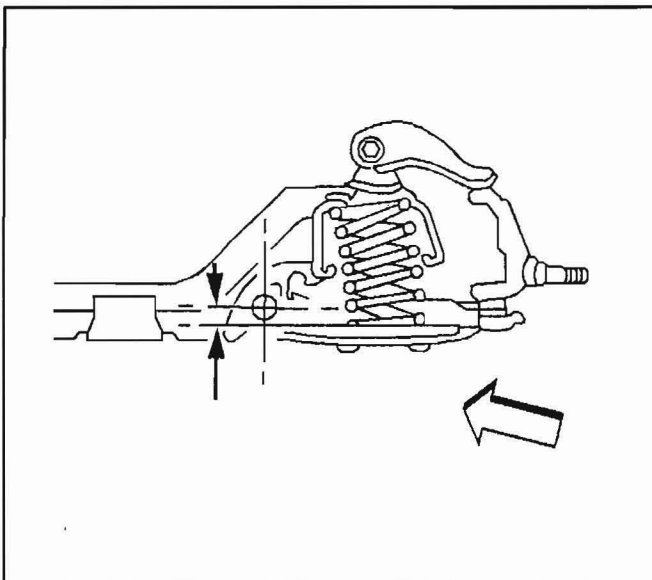

On RWD vehicles, measure Z height from the center line of the bolt of the front lower control arm down to the lower inboard corner of the ball joint. Trim all Z heights at 67.0-79.0 mm (2.6-3.0 in).

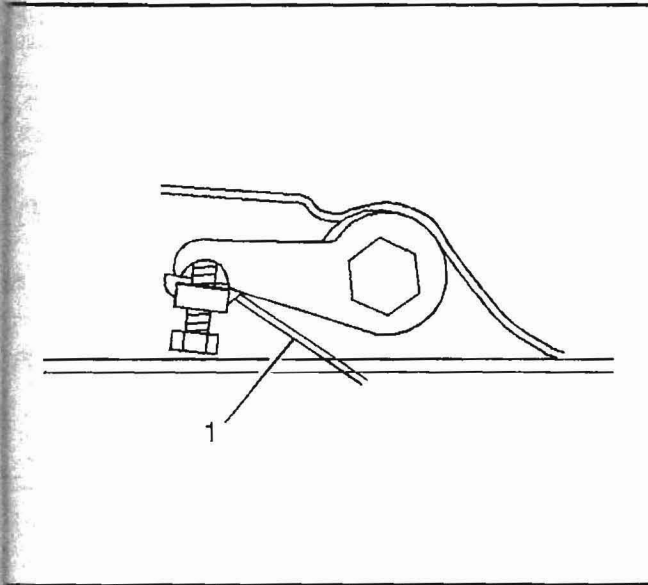

92

Trim all curb Z heights at 114.0-128.0 mm (4.6-5.0 in). To adjust Z height, turn the bolt that contacts the torsion arm as needed. One revolution of the bolt into the nut increases the Z height by 6.0 mm (0.2 in) (1).

Z Height Measurement

Measure the Z height using the following procedure:

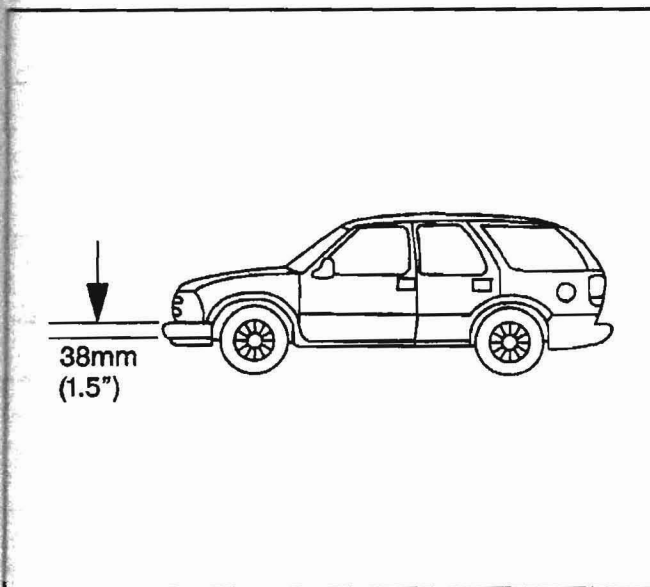

130874

1. Lift the front bumper of the vehicle up around 38 mm (1.5 in).
2. Gently remove your hands. Let the vehicle settle by itself.
3. Repeat the jounce operation two more times for a total of three times.
4. Measure the Z dimension.
5. Push the front bumper of the vehicle down about 38 mm (1.5 in).

6. Gently remove your hands. Let the vehicle rise by itself.
7. Repeat the jounce operation two more times for a total of three times.

Important: True trim height is the average of the high and low measurements.

8. Measure the Z dimension.
9. Find the average of the high and low measurements. This is the true Z dimension.

D Height

The D dimension measurement determines the proper rear end ride height. Even though the D dimension is the same for RWD and 4WD vehicles, the dimension differs between the utility and pickup models. There is no adjustment procedure. Repair may require replacement of suspension components.

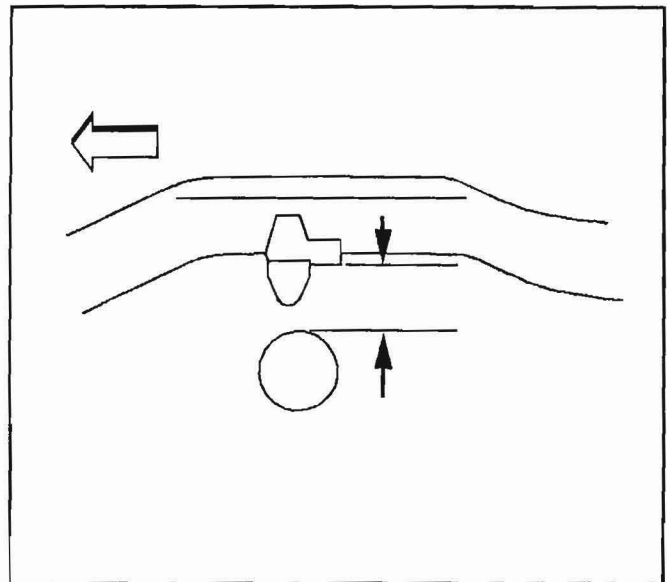

93

All vehicles require a measurement from the bumper bracket down to the top of the rear axle housing tube. Trim Utility D height at 130.8-148.11 mm (5.1- 5.8 in). Trim Pickup D height at 130.7-161.5 mm (5.1-6.4 in).

D Height Measurement

Measure the D height using the following procedure:

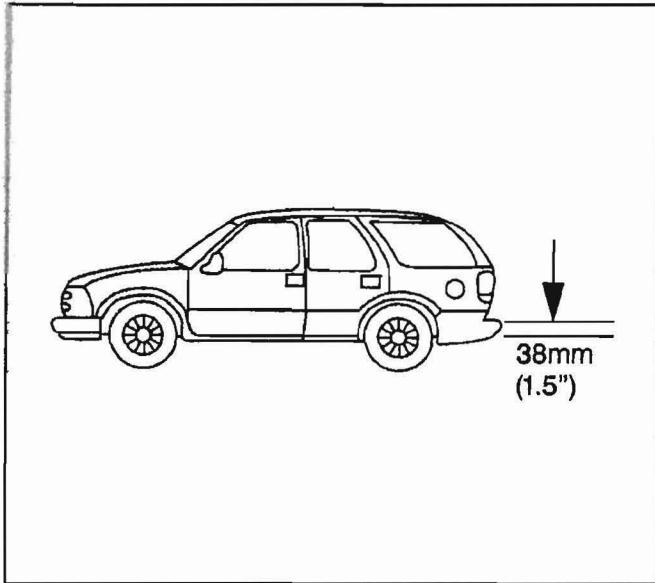

130875

1. Lift the rear bumper of the vehicle up around 38 mm (1.5 in).
2. Gently remove your hands. Let the vehicle settle by itself.

3. Repeat the jounce operation two more times for a total of three times.
4. Measure the D dimension.
5. Push the front bumper of the vehicle down about 38 mm (1.5 in).
6. Gently remove your hands. Let the vehicle rise by itself.
7. Repeat the jounce operation two more times for a total of three times.

Important: True trim height is the average of the high and low measurements.

8. Measure the D dimension.
9. Find the average of the high and low measurements. This is the true D dimension.

Poor Directional Stability

Checks	Action
Lack of lubrication of the ball joints and the steering linkage	Lubricate the ball joints and the linkage. Refer to <i>Fluid and Lubricant Recommendations</i> in Maintenance and Lubrication.
Low or uneven front or rear tire pressure	Inflate the tires to the recommended pressure. Refer to <i>Tire Inflation Description</i> in Tires and Wheels.
Worn or loose hub and wheel bearing	Replace the hub and wheel bearing assembly. Refer to <i>Wheel Hub, Bearing, and Seal Replacement (RWD Pickup) or Wheel Hub, Bearing, and Seal Replacement (4WD Pickup and Utilities)</i> in Front Suspension.
Incorrect front wheel alignment (caster)	Check and align the front suspension. Refer to <i>Wheel Alignment Specifications</i> in Wheel Alignment.
Broken or sagging spring	Replace the spring. Refer to <i>Front Coil Springs Replacement</i> in Front Suspension.
Broken or sagging torsion bars	Adjust the torsion bar. Refer to <i>Trim Height Inspection Procedure</i> .
Malfunctioning shock absorber	Check and replace the shock absorber. Refer to <i>Shock Absorber Replacement (RWD) or Shock Absorber Replacement (4WD)</i> in Front Suspension.
Broken stabilizer shaft or a missing link	Replace the stabilizer shaft or link. Refer to <i>Stabilizer Shaft Replacement (RWD) or Stabilizer Shaft Replacement (4WD)</i> in Front Suspension.

Tire Hop or Poor Handling

Condition	Correction
DEFINITION: The tire/wheel bounce with a frequency directly related to vehicle speed.	
Tire/wheels are unbalanced	Balance the tire/wheels. Refer to <i>Balancing Tires and Wheels</i> in Vibration Diagnosis.
Tire exhibits a blister or bump	Replace the tire. Refer to <i>Tire Repair</i> in Tires and Wheels.
Improper shock absorber action	Replace the shock absorber. <ul style="list-style-type: none"> • Refer to <i>Shock Absorber Replacement (RWD) or Shock Absorber Replacement (4WD)</i> in Front Suspension. • Refer to <i>Shock Absorber Replacement</i> in Rear Suspension.
Excessive wheel or tire runout	Refer to <i>Tire and Wheel Vibration</i> in Vibration Diagnosis.
Tire lead/pull	Refer to <i>Radial Tire Lead/Pull Correction</i> in Tires and Wheels.